



**Ninja ZX-7RR**  
**Ninja ZX-7R**

# **Motorcycle**

# **Service Manual**

Read OWNER'S MANUAL before

## LIST OF ABBREVIATIONS

A	ampere(s)	lb	pound(s)
ABDC	after bottom dead center	m	meter(s)
AC	alternating current	min	minute(s)
ATDC	after top dead center	N	newton(s)
BBDC	before bottom dead center	Pa	pascal(s)
BDC	bottom dead center	PS	horsepower
BTDC	before top dead center	psi	pound(s) per square inch
°C	degree(s) Celcius	r	revolution
DC	direct current	rpm	revolution(s) per minute
F	farad(s)	TDC	top dead center
°F	degree(s) Fahrenheit	TIR	total indicator reading
ft	foot, feet	V	volt(s)
g	gram(s)	W	watt(s)
h	hour(s)	Ω	ohm(s)
L	liter(s)		

**Read OWNER'S MANUAL before operating.**

# Quick Reference Guide

<b>General Information</b>	<b>1</b>
<b>Fuel System</b>	<b>2</b>
<b>Cooling System</b>	<b>3</b>
<b>Engine Top End</b>	<b>4</b>
<b>Clutch</b>	<b>5</b>
<b>Engine Lubrication System</b>	<b>6</b>
<b>Engine Removal/Installation</b>	<b>7</b>
<b>Crankshaft/Transmission</b>	<b>8</b>
<b>Wheels/Tires</b>	<b>9</b>
<b>Final Drive</b>	<b>10</b>
<b>Brakes</b>	<b>11</b>
<b>Suspension</b>	<b>12</b>
<b>Steering</b>	<b>13</b>
<b>Frame</b>	<b>14</b>
<b>Electrical System</b>	<b>15</b>
<b>Appendix</b>	<b>16</b>

This quick reference guide will assist you in locating a desired topic or procedure.

- Bend the pages back to match the black tab of the desired chapter number with the black tab on the edge at each table of contents page.
- Refer to the sectional table of contents for the exact pages to locate the specific topic required.

# Quick Reference Guide

1	General Information
2	Fuel System
3	Cooling System
4	Engine Top End
5	Clutch
6	Engine Lubrication System
7	Engine Removal/Installation
8	Classical Transmission
9	Final Drive
10	Final Drive
11	Brakes
12	Steering
13	Steering
14	Frame
15	Electrical System
16	Electrical System
17	Appendix
18	Appendix

The information in this manual is intended to provide a general overview of the vehicle's operation and maintenance. It is not intended to be a substitute for the manufacturer's instructions. Always use the manufacturer's instructions for the correct operation and maintenance of the vehicle. The information in this manual is provided for informational purposes only. It is not intended to be a substitute for the manufacturer's instructions. Always use the manufacturer's instructions for the correct operation and maintenance of the vehicle.

## EMISSION CONTROL INFORMATION

To protect the environment in which we all live, Kawasaki has incorporated crankcase emission (1) and exhaust emission (2) control systems in compliance with applicable regulations of the United States Environmental Protection Agency and California Air Resources Board. Additionally, Kawasaki has incorporated an evaporative emission control system (3) in compliance with applicable regulations of the California Air Resources Board on vehicles sold in California only.

### 1. Crankcase Emission Control System

This system eliminates the release of crankcase vapors into the atmosphere. Instead, the vapors are routed through an oil separator to the intake side of the engine. While the engine is operating, the vapors are drawn into combustion chamber, where they are burned along with the fuel and air supplied by the carburetion system.

### 2. Exhaust Emission Control System

This system reduces the amount of pollutants discharged into the atmosphere by the exhaust of this motorcycle. The fuel and ignition systems of this motorcycle have been carefully designed and constructed to ensure an efficient engine with low exhaust pollutant levels.

### 3. Evaporative Emission Control System

Vapors caused by fuel evaporation in the fuel system are not vented into the atmosphere. Instead, fuel vapors are routed into the running engine to be burned, or stored in a canister when the engine is stopped. Liquid fuel is caught by a vapor separator and returned to the fuel tank.

The Clean Air Act, which is the Federal law covering motor vehicle pollution, contains what is commonly referred to as the Act's "tampering provisions."

"Sec. 203(a) The following acts and the causing thereof are prohibited...

(3)(A) for any person to remove or render inoperative any device or element of design installed on or in a motor vehicle or motor vehicle engine in compliance with regulations under this title prior to its sale and delivery to the ultimate purchaser, or for any manufacturer or dealer knowingly to remove or render inoperative any such device or element of design after such sale and delivery to the ultimate purchaser.

(3)(B) for any person engaged in the business of repairing, servicing, selling, leasing, or trading motor vehicles or motor vehicle engines, or who operates a fleet of motor vehicles knowingly to remove or render inoperative any device or element of design installed on or in a motor vehicle or motor vehicle engine in compliance with regulations under this title following its sale and delivery to the ultimate purchaser..."

(Continued on next page.)

## NOTE

- *The phrase "remove or render inoperative any device or element of design" has been generally interpreted as follows:*
  1. *Tampering does not include the temporary removal or rendering inoperative of devices or elements of design in order to perform maintenance.*
  2. *Tampering could include:*
    - a. *Maladjustment of vehicle components such that the emission standards are exceeded.*
    - b. *Use of replacement parts or accessories which adversely affect the performance or durability of the motorcycle.*
    - c. *Addition of components or accessories that result in the vehicle exceeding the standards.*
    - d. *Permanently removing, disconnecting, or rendering inoperative any component or element of design of the emission control systems.*

**WE RECOMMEND THAT ALL DEALERS OBSERVE THESE PROVISIONS OF FEDERAL LAW, THE VIOLATION OF WHICH IS PUNISHABLE BY CIVIL PENALTIES NOT EXCEEDING \$10,000 PER VIOLATION.**

## TAMPERING WITH NOISE CONTROL SYSTEM PROHIBITED

Federal law prohibits the following acts or the causing thereof: (1) The removal or rendering inoperative by any person other than for purposes of maintenance, repair, or replacement, of any device or element of design incorporated into any new vehicle for the purpose of noise control prior to its sale or delivery to the ultimate purchaser or while it is in use, or (2) the use of the vehicle after such device or element of design has been removed or rendered inoperative by any person.

Among those acts presumed to constitute tampering are the acts listed below:

- Replacement of the original exhaust system or muffler with a component not in compliance with Federal regulations.
- Removal of the muffler(s) or any internal portion of the muffler(s).
- Removal of the air box or air box cover.
- Modifications to the muffler(s) or air intake system by cutting, drilling, or other means if such modifications result in increased noise levels.

# Foreword

This manual is designed primarily for use by trained mechanics in a properly equipped shop. However, it contains enough detail and basic information to make it useful to the owner who desires to perform his own basic maintenance and repair work. A basic knowledge of mechanics, the proper use of tools, and workshop procedures must be understood in order to carry out maintenance and repair satisfactorily. Whenever the owner has insufficient experience or doubts his ability to do the work, all adjustments, maintenance, and repair should be carried out only by qualified mechanics.

In order to perform the work efficiently and to avoid costly mistakes, read the text, thoroughly familiarize yourself with the procedures before starting work, and then do the work carefully in a clean area. Whenever special tools or equipment are specified, do not use makeshift tools or equipment. Precision measurements can only be made if the proper instruments are used, and the use of substitute tools may adversely affect safe operation.

**For the duration of the warranty period,** we recommend that all repairs and scheduled maintenance be performed in accordance with this service manual. Any owner maintenance or repair procedure not performed in accordance with this manual may void the warranty.

To get the longest life out of your motorcycle:

- Follow the Periodic Maintenance Chart in the Service Manual.
- Be alert for problems and non-scheduled maintenance.
- Use proper tools and genuine Kawasaki Motorcycle parts. Special tools, gauges, and testers that are necessary when servicing Kawasaki motorcycles are introduced by the Special Tool Manual. Genuine parts provided as spare parts are listed in the Parts Catalog.
- Follow the procedures in this manual carefully. Don't take shortcuts.
- Remember to keep complete records of maintenance and repair with dates and any new parts installed.

---

## How to Use This Manual

---

In preparing this manual, we divided the product into its major systems. These systems became the manual's chapters. All information for a particular system from adjustment through disassembly and inspection is located in a single chapter.

The Quick Reference Guide shows you all of the product's system and assists in locating their chapters. Each chapter in turn has its own comprehensive Table of Contents.

The Periodic Maintenance Chart is located in the General Information chapter. The chart gives a time schedule for required maintenance operations.

If you want spark plug information, for example, go to the Periodic Maintenance Chart first. The chart tells you how frequently to clean and gap the plug. Next, use the Quick Reference Guide to locate the Electrical System chapter. Then, use the Table of Contents on the first page of the chapter to find the Spark Plug section.

Whenever you see these WARNING and CAUTION symbols, heed their instructions! Always follow safe operating and maintenance practices.

### **▲WARNING**

**This warning symbol identifies special instructions or procedures which, if not correctly followed, could result in personal injury, or loss of life.**

### **CAUTION**

**This caution symbol identifies special instructions or procedures which, if not strictly observed, could result in damage to or destruction of equipment.**

This manual contains four more symbols (in addition to WARNING and CAUTION) which will help you distinguish different types of information.

#### NOTE

○ *This note symbol indicates points of particular interest for more efficient and convenient operation.*

- Indicates a procedural step or work to be done.
- Indicates a procedural sub-step or how to do the work of the procedural step it follows. It also precedes the text of a NOTE.
- ★ Indicates a conditional step or what action to take based on the results of the test or inspection in the procedural step or sub-step it follows.

In most chapters an exploded view illustration of the system components follows the Table of Contents. In these illustrations you will find the instructions indicating which parts require specified tightening torque, oil, grease or a locking agent during assembly.



# General Information

## Table of Contents

Before Servicing .....	1-2
Model Identification .....	1-4
General Specifications .....	1-8
Periodic Maintenance Chart .....	1-12
Technical Information - Maintenance Free Battery .....	1-13
Technical Information - Flat CR Slide Carburetor .....	1-17
Technical Information - Side Camshaft Chain .....	1-19
Technical Information - Engine Lubrication System .....	1-20
Technical Information - Connecting Rod Big End Nut Tightening .....	1-21
Technical Information - Swingarm .....	1-24
Technical Information - Alternator Unit .....	1-24
Torque and Locking Agent .....	1-25
Special Tools and Sealant .....	1-30
Cable, Wire, and Hose Routing .....	1-36

### Before Servicing

---

Before starting to service a motorcycle, careful reading of the applicable section is recommended to eliminate unnecessary work. Photographs, diagrams, notes, cautions, warnings, and detailed descriptions have been included wherever necessary. Nevertheless, even a detailed account has limitations, a certain amount of basic knowledge is also required for successful work.

#### Especially note the following:

- (1) **Dirt**

Before removal and disassembly, clean the motorcycle. Any dirt entering the engine or other parts will work as an abrasive and shorten the life of the motorcycle. For the same reason, before installing a new part, clean off any dust or metal filings.
- (2) **Battery Ground**

Remove the ground (-) lead from the battery before performing any disassembly operations on the motorcycle. This prevents:

  - (a) the possibility of accidentally turning the engine over while partially disassembled.
  - (b) sparks at electrical connections which will occur when they are disconnected.
  - (c) damage to electrical parts.
- (3) **Tightening Sequence**

Generally, when installing a part with several bolts, nuts, or screws, start them all in their holes and tighten them to a snug fit. Then tighten them evenly in a cross pattern. This is to avoid distortion of the part and/or causing gas or oil leakage. Conversely when loosening the bolts, nuts, or screws, first loosen all of them by about a quarter turn and then remove them. Where there is a tightening sequence indication in this Service Manual, the bolts, nuts, or screws must be tightened in the order and method indicated.
- (4) **Torque**

When torque values are given in this Service Manual, use them. Either too little or too much torque may lead to serious damage. Use a good quality, reliable torque wrench.
- (5) **Force**

Common sense should dictate how much force is necessary in assembly and disassembly. If a part seems especially difficult to remove or install, stop and examine what may be causing the problem. Whenever tapping is necessary, tap lightly using a wooden or plastic-faced mallet. Use an impact driver for screws (particularly for the removal of screws held by a locking agent) in order to avoid damaging the screw heads.
- (6) **Edges**

Watch for sharp edges, especially during major engine disassembly and assembly. Protect your hands with gloves or a piece of thick cloth when lifting the engine or turning it over.
- (7) **High-Flash Point Solvent**

A high-flash point solvent is recommended to reduce fire danger. A commercial solvent commonly available in North America is Stoddard solvent (generic name). Always follow manufacturer and container directions regarding the use of any solvent.
- (8) **Gasket, O-Ring**

Do not reuse a gasket or O-ring once it has been in service. The mating surfaces around the gasket should be free of foreign matter and perfectly smooth to avoid oil or compression leaks.
- (9) **Liquid Gasket, Non-Permanent Locking Agent**

Follow manufacturer's directions for cleaning and preparing surfaces where these compounds will be used. Apply sparingly. Excessive amounts may block engine oil passages and cause serious damage. An example of a non-permanent locking agent commonly available in North America is Loctite Lock'n Seal (Blue).
- (10) **Press**

A part installed using a press or driver, such as a wheel bearing, should first be coated with oil on its outer or inner circumference so that it will go into place smoothly.
- (11) **Ball Bearing and Needle Bearing**

Do not remove any ball or needle bearings that are pressed in unless it is necessary. If they are removed, replace them with new ones.

When installing a bearing, press it in with the marked side facing out using a suitable driver until it is bottomed. Bearings should be pressed into place by pushing evenly the bearing race which is affected by friction.

(12) Oil Seal and Grease Seal

Replace any oil or grease seals that were removed with new ones, as removal generally damages seals. When pressing in a seal which has manufacturer's marks, press it in with the marks facing out. Seals should be pressed into place using a suitable driver, which contacts evenly with the side of seal, until the face of the seal is even with the end of the hole.

(13) Seal Guide

A seal guide is required for certain oil or grease seals during installation to avoid damage to the seal lips. Before a shaft passes through a seal, apply a little high temperature grease on the lips to reduce rubber to metal friction.

(14) Circlip, Retaining Ring

Replace any circlips and retaining rings that were removed with new ones, as removal weakens and deforms them. When installing circlips and retaining rings, take care to compress or expand them only enough to install them and no more.

(15) Cotter Pin

Replace any cotter pins that were removed with new ones, as removal deforms and breaks them.

(16) Lubrication

Engine wear is generally at its maximum while the engine is warming up and before all the rubbing surfaces have an adequate lubricative film. During assembly, oil or grease (whichever is more suitable) should be applied to any rubbing surface which has lost its lubricative film. Old grease and dirty oil should be cleaned off. Deteriorated grease has lost its lubricative quality and may contain abrasive foreign particles.

Don't use just any oil or grease. Some oils and greases in particular should be used only in certain applications and may be harmful if used in an application for which they are not intended. This manual makes reference to molybdenum disulfide grease (MoS<sub>2</sub>) in the assembly of certain engine and chassis parts. Always check manufacturer recommendations before using such special lubricants.

(17) Electrical Wires

All the electrical wires are either single-color or two-color and, with only a few exceptions, must be connected to wires of the same color. On any of the two-color wires there is a greater amount of one color and a lesser amount of a second color, so a two-color wire is identified by first the primary color and then the secondary color. For example, a yellow wire with thin red stripes is referred to as a "yellow/red" wire; it would be a "red/yellow" wire if the colors were reversed to make red the main color.

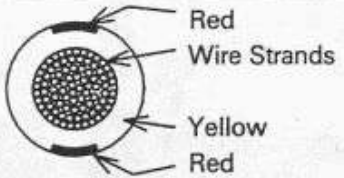
Wire (cross-section)	Name of Wire Color
	Yellow/Red

(18) Replacement Parts

When there is a replacement instruction, replace these parts with new ones every time they are removed. These replacement parts will be damaged or lose their original function once removed.

(19) Inspection

When parts have been disassembled, visually inspect these parts for the following conditions or other damage. If there is any doubt as to the condition of them, replace them with new ones.

Abrasion	Crack	Hardening	Warp
Bent	Dent	Scratch	Wear
Color change	Deterioration	Seizure	

(20) Specifications

Specification terms are defined as follows:

"Standards" show dimensions or performances which brand-new parts or systems have.

"Service Limits" indicate the usable limits. If the measurement shows excessive wear or deteriorated performance, replace the damaged parts.

## 1-4 GENERAL INFORMATION

### Model Identification

#### ZX750-N1 (US and Canada Models) Left Side View:

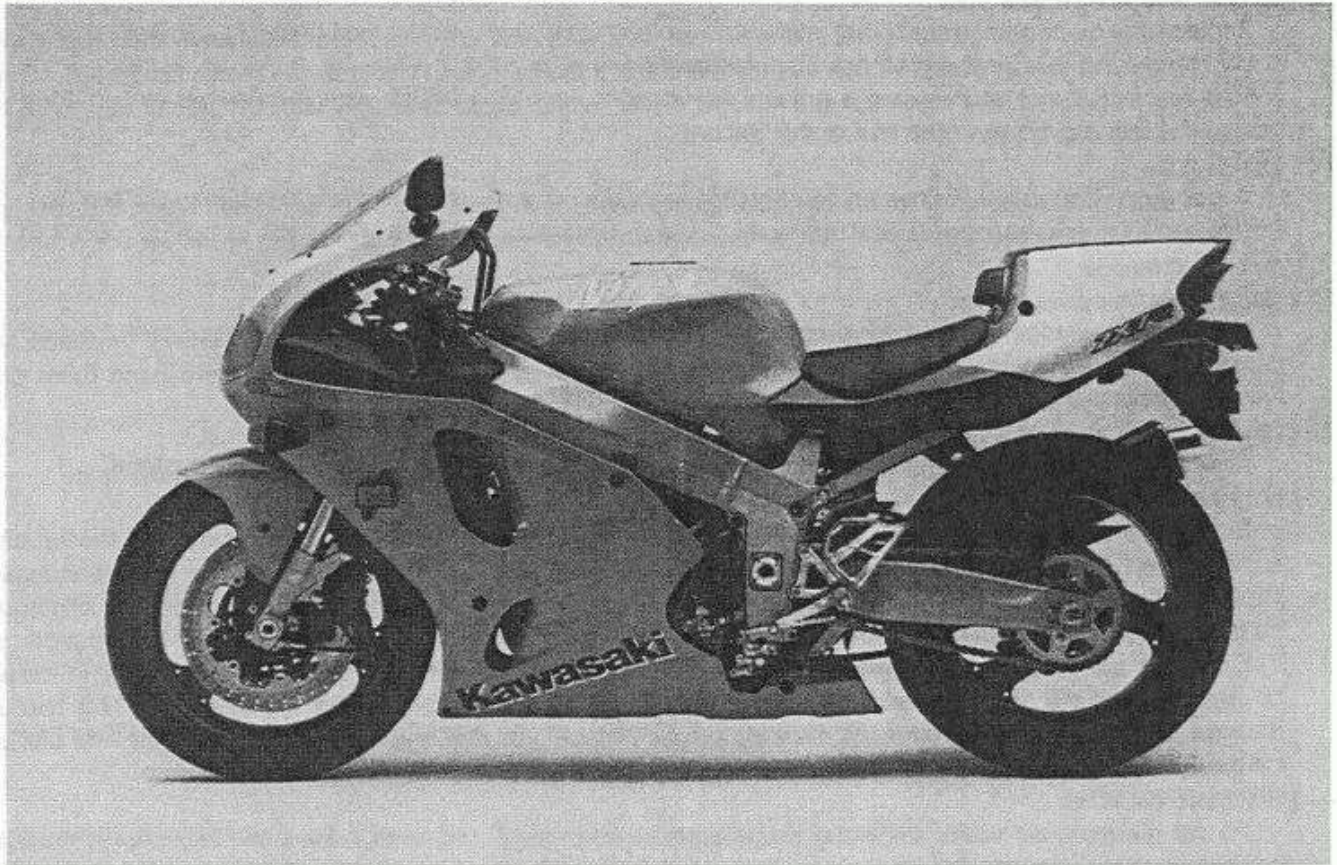

#### ZX750-N1 (US and Canada Models) Right Side View:

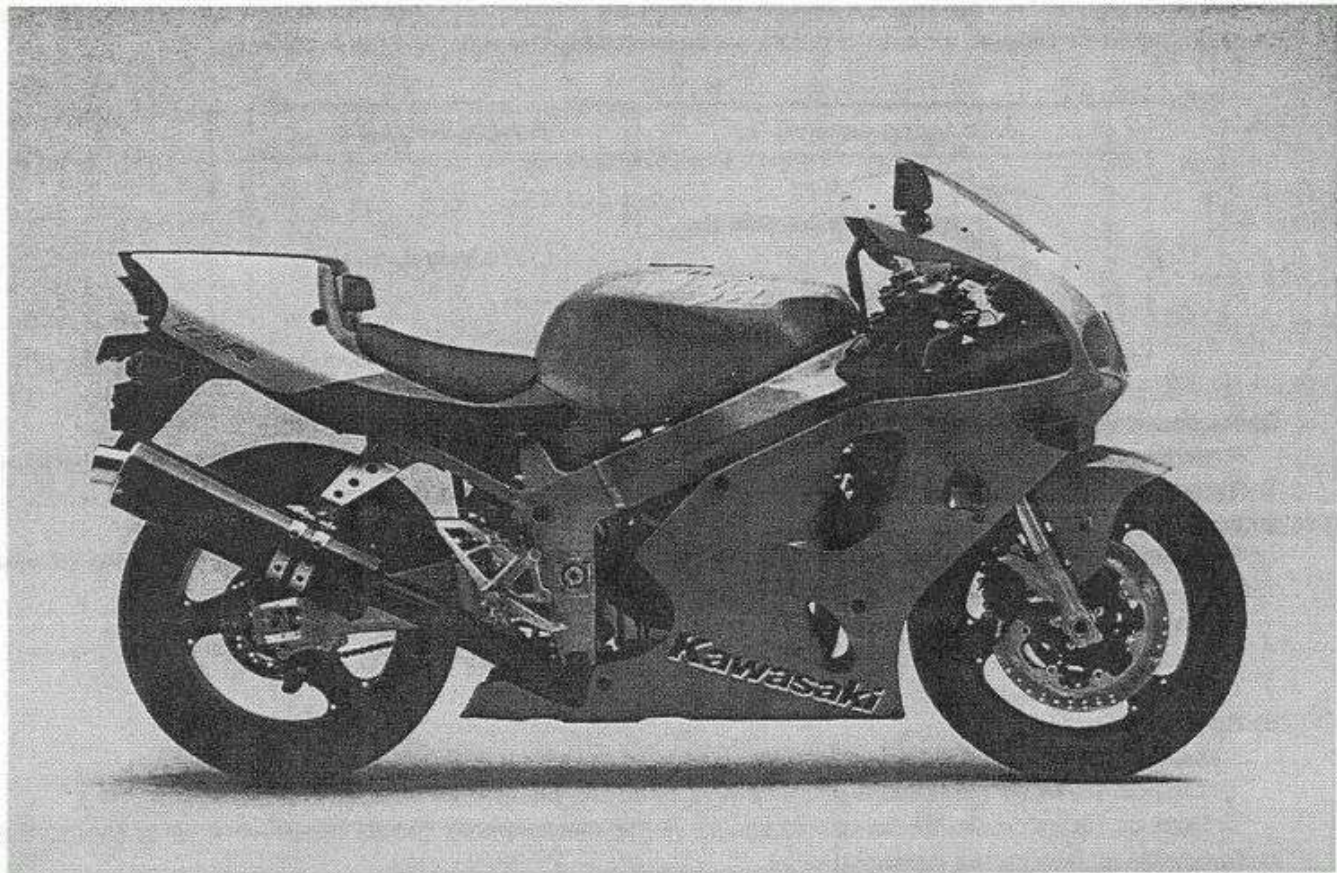

ZX750-N1 (Europe Model) Left Side View:

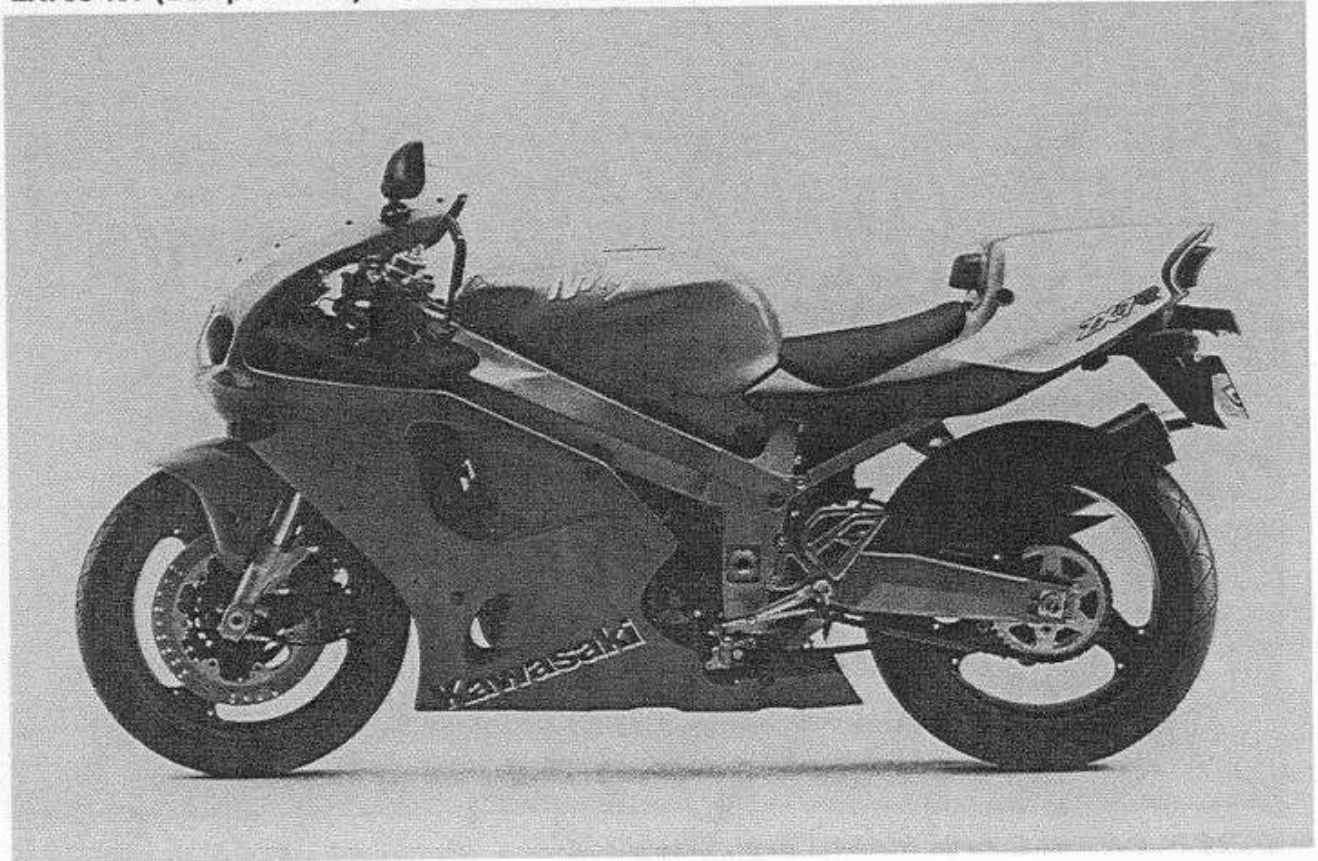

ZX750-N1 (Europe Model) Right Side View:

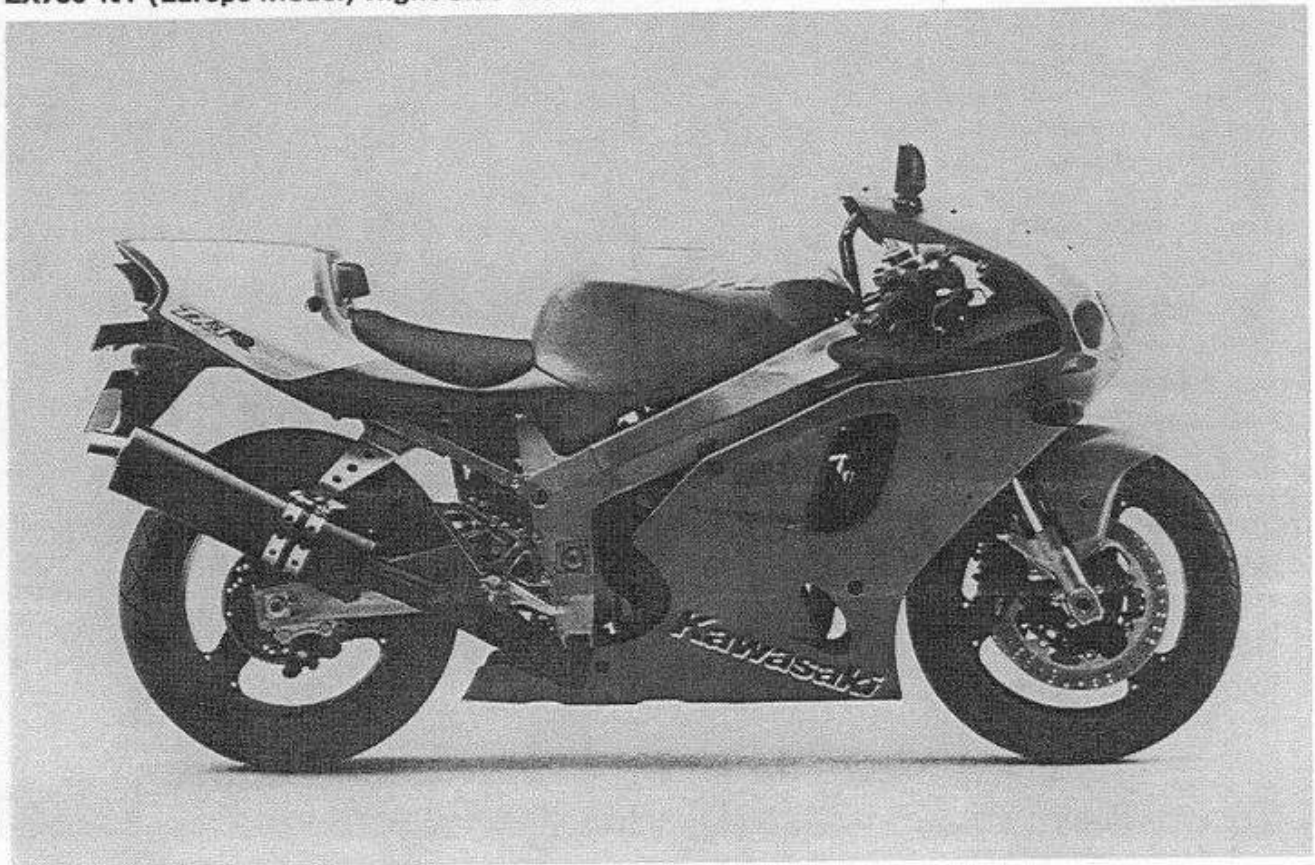

**ZX750-P1 (US and Canada Models) Left Side View:**

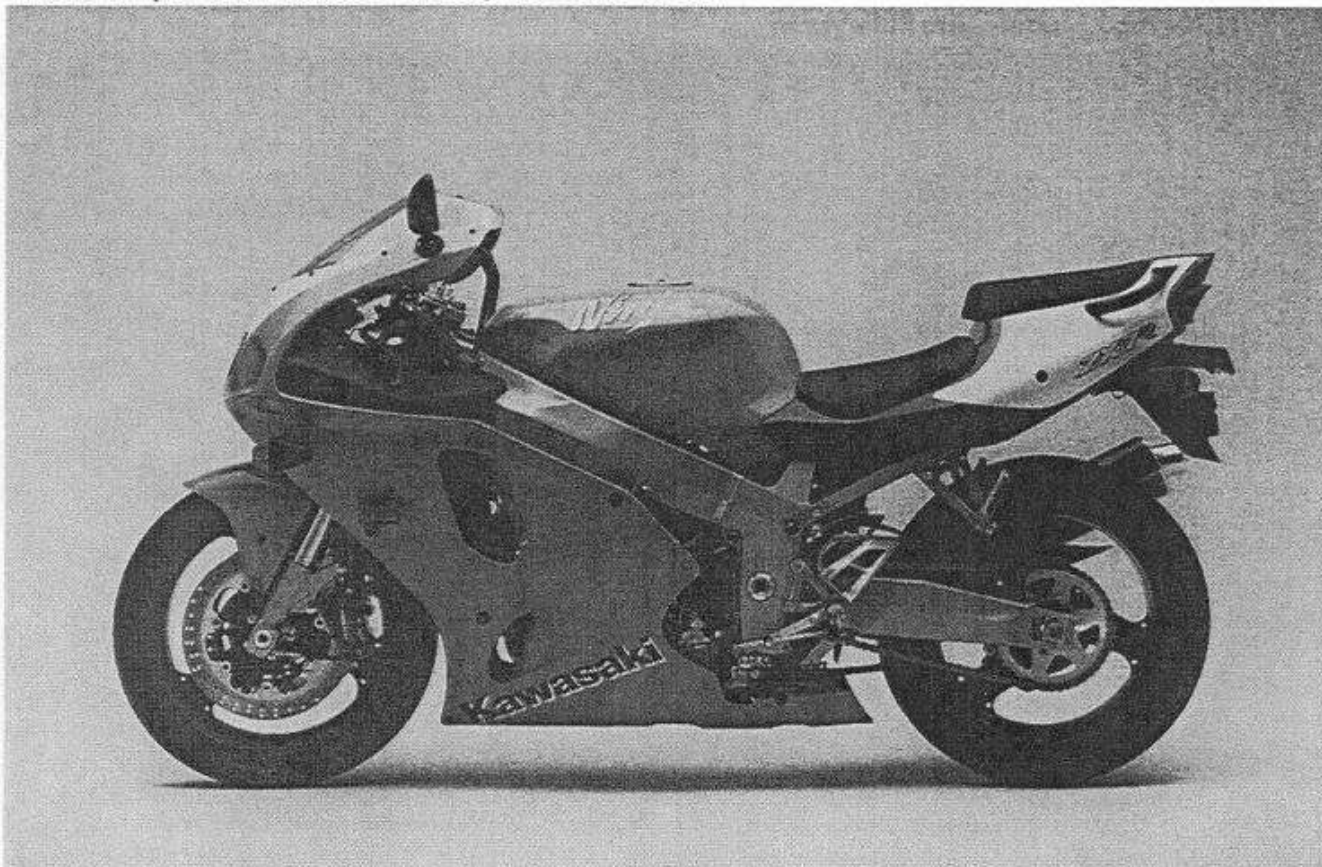

**ZX750-P1 (US and Canada Models) Right Side View:**

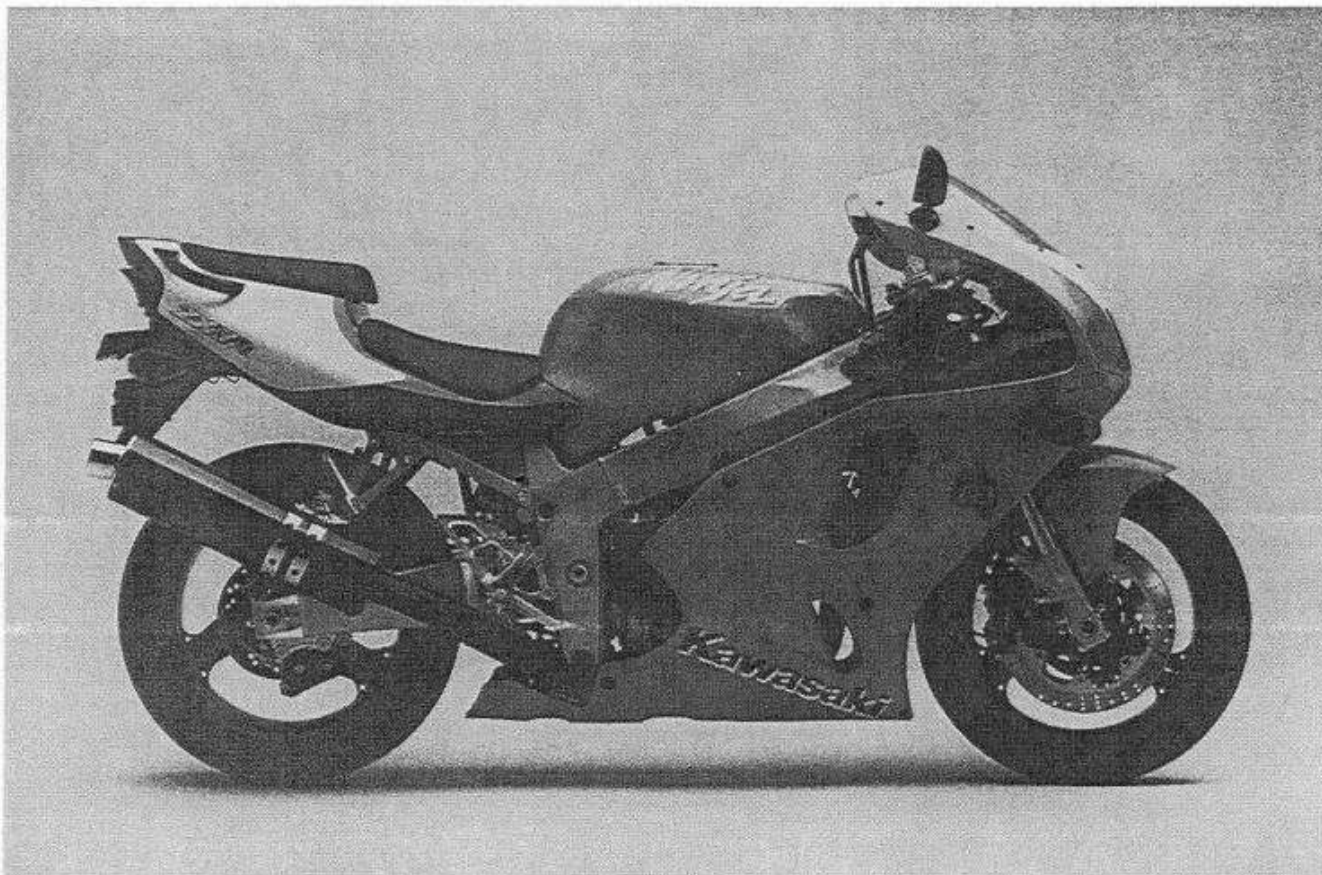

ZX750-P1 (Europe Model) Left Side View:

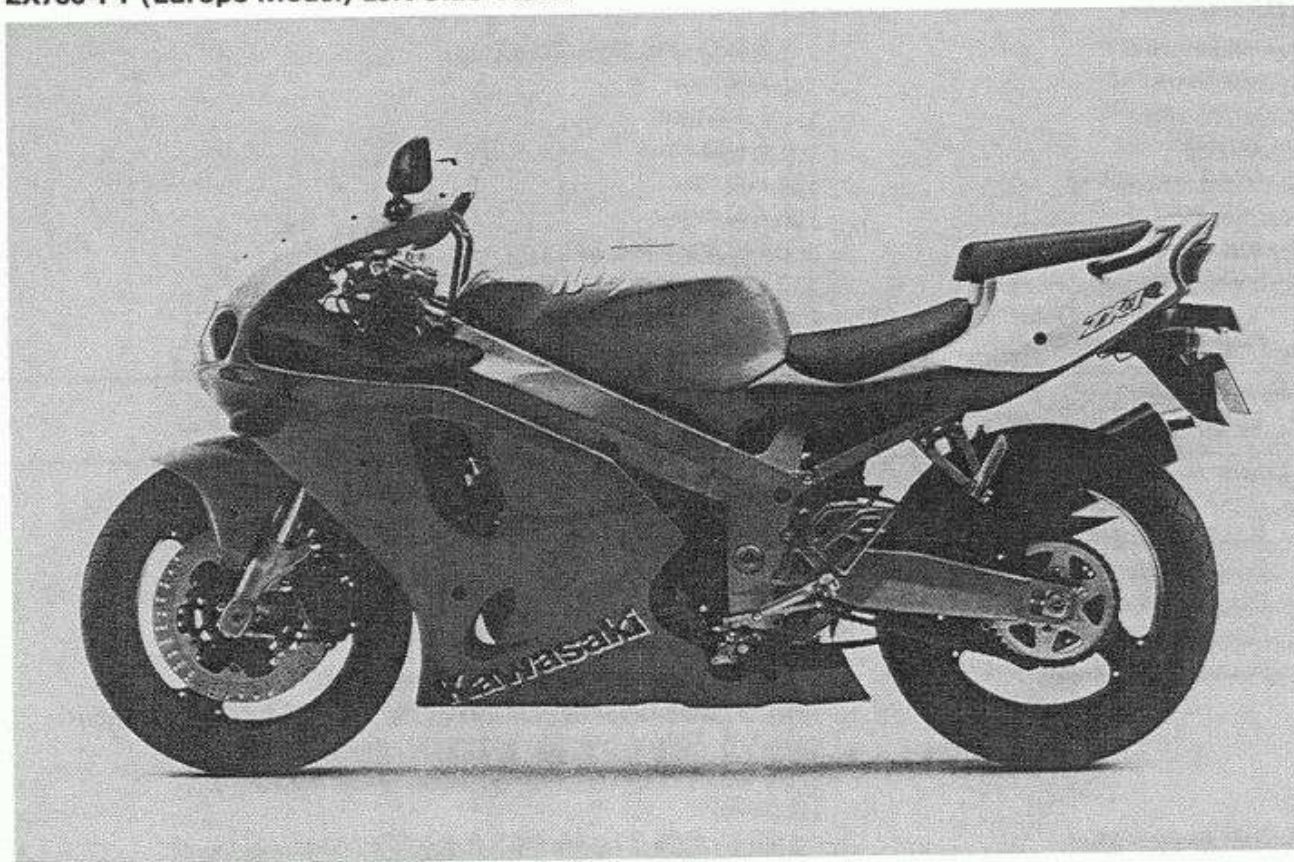

ZX750-P1 (Europe Model) Right Side View:

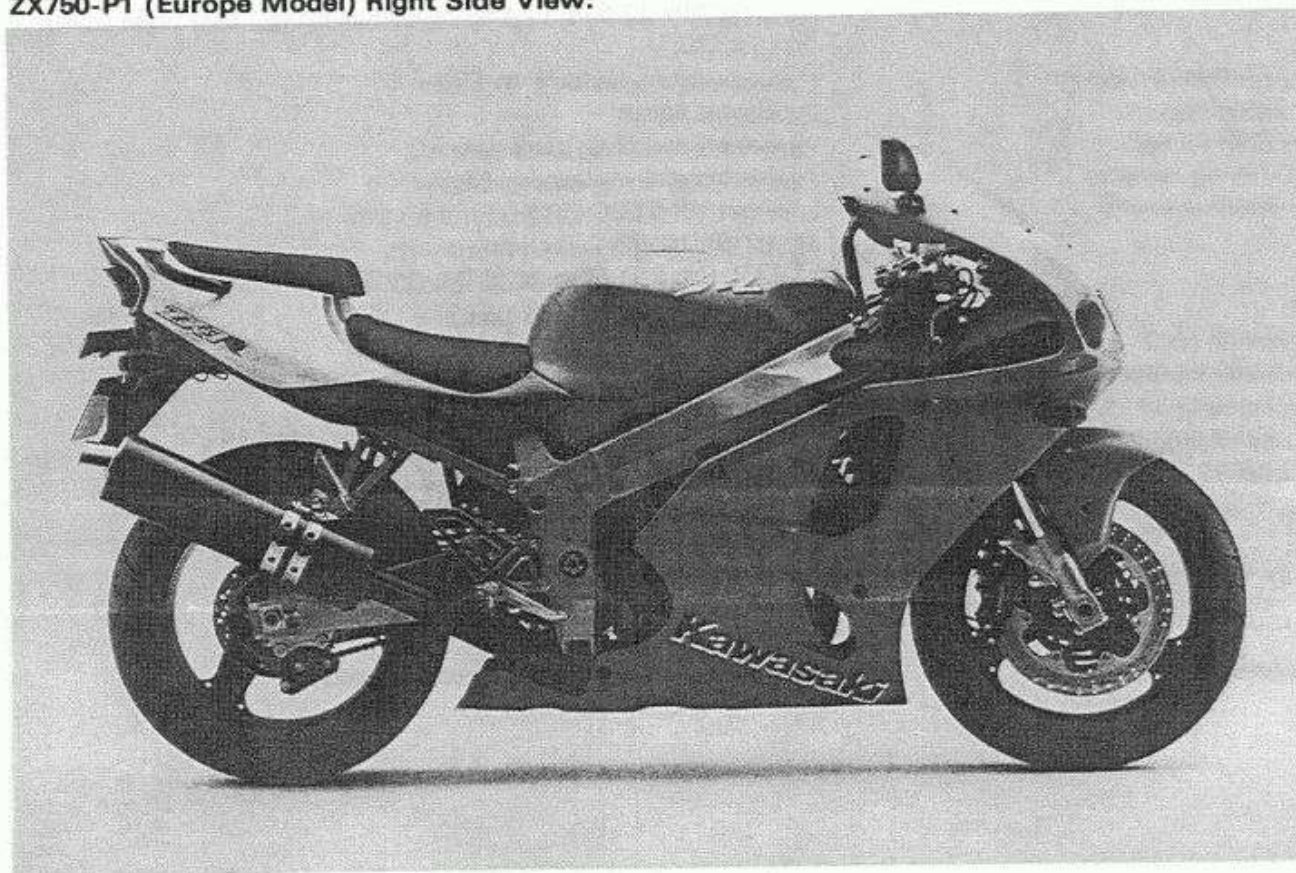

# 1-8 GENERAL INFORMATION

## General Specifications

Item	ZX750-N1, N2
<b>Dimensions:</b>	
Overall length	2 090 mm, (FG) 2 190 mm
Overall width	740 mm
Overall height	1 130mm
Wheelbase	1 420 mm
Road clearance	105 mm
Seat height	790 mm
Dry weight	200 kg, (CA) 201 kg
Curb weight:	
Front	117 kg, (CA) 117.5 kg
Rear	112 kg, (CA) 112.5 kg
Fuel tank capacity	18.0 L
<b>Performance:</b>	
Minimum turning radius	3.4 m
<b>Engine:</b>	
Type	4-stroke, DOHC, 4-cylinder
Cooling system	Liquid-cooled
Bore and stroke	73.0 x 44.7 mm
Displacement	748 mL
Compression ratio	11.5, (FR) 10.8
Maximum horsepower	90 kW (122 PS) @12 000 r/min (rpm), (FR) UTAC's norm 75.1 kW (102 PS) @11 500 r/min (rpm), (AR) 72 kW (98 PS) @12 000 r/min (rpm), (FG) DIN 72kW (98 PS) @12 000 r/min (rpm), (US) -
Maximum torque	78 N-m (8.0 kg-m, 57.9 ft-lb) @9 300 r/min (rpm), (AR) 73 N-m (7.4 kg-m, 53.5 ft-lb) @7 000 r/min (rpm), (FG) DIN 73 N-m (7.4 kg-m, 53.5 ft-lb) @7 000 r/min (rpm), (FR, US) -
Carburetion system	Carburetors, Keihin FVK-D41 x 4
Starting system	Electric starter
Ignition system	Battery and coil (transistorized)
Timing advance	Electronically advanced (digital)
Ignition timing	From 10° BTDC @1 100 r/min (rpm) to 45° BTDC @5 000 r/min (rpm) (AR, CA, FG) From 5° BTDC @1 300 r/min (rpm) to 40° BTDC @5 000 r/min (rpm)
Spark plug	NGK CR9E or ND U27ESR-N
Cylinder numbering method	Left to right, 1-2-3-4
Firing order	1-2-4-3
Valve timing:	
Inlet	Open
	Close
	Duration
Exhaust	Open
	Close
	Duration
Lubrication system	Forced lubrication (wet sump with cooler)



Item		ZX750-N1, N2
Engine oil:	Grade Viscosity Capacity	SE, SF or SG class SAE10W-40, 10W-50, 20W-40, or 20W-50 3.6 L
<b>Drive Train:</b>		
Primary reduction system:		
	Type	Gear
	Reduction ratio	1.754 (93/53)
Clutch type		Wet multi disc
Transmission:		
	Type	6-speed, constant mesh, return shift
Gear ratios:		
	1st	2.375 (38/16)
	2nd	1.894 (36/19)
	3rd	1.619 (34/21)
	4th	1.409 (31/22)
	5th	1.291 (31/24)
	6th	1.200 (30/25)
Final drive system:		
	Type	Chain drive
	Reduction ratio	2.625 (42/16)
	Overall drive ratio	5.527 @Top gear
<b>Frame:</b>		
Type		Press, diamond
Caster (rake angle)		25°
Trail		99 mm
Front tire:		
	Type	Tubeless
	Size	120/70 ZR17
Rear tire:		
	Type	Tubeless
	Size	190/50 ZR17
Front suspension:		
	Type	Telescopic fork
	Wheel travel	120 mm
Rear suspension:		
	Type	Swing arm (uni-trak)
	Wheel travel	130 mm
Brake type:		
	Front	Dual discs
	Rear	Single disc
<b>Electrical Equipment:</b>		
Battery		12 V 8 Ah
Headlight:		
	Type	Semi-sealed beam
	Bulb	Quartz-halogen
		Left 12 V 55 W, Right 12 V 55 W
		(US, CN, UK) 12 V 45/45 W x 2
Tail/brake light		12 V 5/21 W x 2, (US, CN) 12 V 8/27W x 2
Alternator:		
	Type	Three-phase AC
	Rated output	30.7 A / 14 V @6 000 r/min (rpm)

Specifications are subject to change without notice, and may not apply to every country.

(AR) : Austria Model  
 (CA) : California Model  
 (CN) : Canada Model  
 (FG) : Germany Model  
 (FR) : France Model

(UK) : U.K. Model  
 (US) : U.S. Model

# 1-10 GENERAL INFORMATION

Item	ZX750-P1, P2, P3, P4
<b>Dimensions:</b>	
Overall length	2 090 mm, (FG, GR, NR, SD, ST) 2 190 mm
Overall width	740 mm
Overall height	1 130 mm
Wheelbase	1 435 mm
Road clearance	105 mm
Seat height	790 mm
Dry weight	203 kg, (CA) 204 kg
Curb weight:	117 kg, (CA) 117.5 kg
Front	
Rear	115 kg, (CA) 115.5 kg
Fuel tank capacity	18.0 L
<b>Performance:</b>	
Minimum turning radius	3.4 m
<b>Engine:</b>	
Type	4-stroke, DOHC, 4-cylinder
Cooling system	Liquid-cooled
Bore and stroke	73.0 x 44.7 mm
Displacement	748 mL
Compression ratio	11.5, (FR) 10.8
Maximum horsepower	90 kW (122 PS) @11 800 r/min (rpm), (AR) P1 - P3: 72 kW (98 PS) @11 500 r/min (rpm), (FG) P1 - P3: DIN 72 kW (98 PS) @11 500 r/min (rpm), (FR) UTAC's norm 75.1 kW @11 000 r/min (rpm), (SD) 61 kW (83 PS) @9 500 r/min (rpm), (ST) 39 kW (53 PS) @7 500 r/min (rpm), (US) -
Maximum torque	78 N-m (8.0 kg-m, 57.9 ft-lb) @9 300 r/min (rpm), (AR) P1 - P3: 74 N-m (7.5 kg-m, 54.2 ft-lb) @6 800 r/min (rpm), (FG) P1 - P3: DIN 74 N-m (7.5 kg-m, 54.2 ft-lb) @6 800 r/min (rpm), (SD) 70 N-m (7.1 kg-m, 51.4 ft-lb) @6 500 r/min (rpm), (ST) 56 N-m (5.7 kg-m, 41.2 ft-lb) @5 000 r/min (rpm), (FR, US) -
Carburetion system	KEIHIN CVK-D38 x 4
Starting system	Electric starter
Ignition system	Battery and coil (transistorized)
Timing advance	Electronically advanced (digital)
Ignition timing	From 10° BTDC @1 100 r/min (rpm) to 45° BTDC @5 000 r/min (rpm), (AR, CA, FG, ST) From 5° BTDC @1 300 r/min (rpm) to 40° BTDC @5 000 r/min (rpm)
Spark plug	NGK CR9E or ND U27ESR-N
Cylinder numbering method	Left to right, 1-2-3-4
Firing order	1-2-4-3
Valve timing:	
Inlet	Open Close Duration
Exhaust	Open Close Duration
Lubrication system	Forced lubrication (wet sump with cooler)
Engine oil:	SE, SF or SG class
Viscosity	SAE10W-40, 10W-50, 20W-40, or 20W-50
Capacity	3.6 L

Item	ZX750-P1, P2, P3, P4
<b>Drive Train:</b>	
Primary reduction system:	
Type	Gear
Reduction ratio	1.754 (93/53)
Clutch type	Wet multi disc
Transmission:	
Type	6-speed, constant mesh, return shift
Gear ratios:	
1st	2.857 (40/14)
2nd	2.000 (36/18)
3rd	1.619 (34/21)
4th	1.391 (32/23)
5th	1.222 (33/27)
6th	1.103 (32/29)
Final drive system:	
Type	Chain drive
Reduction ratio	2.687 (43/16)
Overall drive ratio	5.203 @Top gear
<b>Frame:</b>	
Type	Press, diamond
Caster (rake angle)	25°
Trail	99 mm
Front tire:	
Type	Tubeless
Size	120/70 ZR17
Rear tire:	
Type	Tubeless
Size	190/50 ZR17
Front suspension:	
Type	Telescopic fork
Wheel travel	120 mm
Rear suspension:	
Type	Swing arm (uni-trak)
Wheel travel	130 mm
Brake type:	
Front	Dual discs
Rear	Single disc
<b>Electrical Equipment:</b>	
Battery	12 V 10 Ah
Headlight:	
Type	Semi-sealed beam
Bulb	Quartz-halogen
	Left 12 V 55 W, Right 12 V 55 W
	(AS, CN, UK, US) 12 V 45/45 W x 2
Tail/brake light	12 V 5/21 W x 2, (US, CA, CN) 12 V 8/27 W x 2
Alternator:	
Type	Three-phase AC
Rated output	30.7 A / 14 V @6 000 r/min (rpm)

Specifications are subject to change without notice, and may not apply to every country.

(AR) : Austria Model

(AS) : Australia Model

(CA) : California Model

(CN) : Canada Model

(FG) : Germany Model

(FR) : France Model

(GR) : Greece Model

(NR) : Norway Model

(SD) : Sweden Model

(ST) : Switzerland Model

(UK) : U.K. Model

(US) : U.S. Model

# 1-12 GENERAL INFORMATION

## Periodic Maintenance Chart

The scheduled maintenance must be done in accordance with this chart to keep the motorcycle in good running condition. The initial maintenance is vitally important and must not be neglected.

OPERATION	FREQUENCY	Which ever comes first		*ODOMETER READING									
		Every	1 000 km (600 mile)	6 000 km (4 000 mile)	12 000 km (7 500 mile)	18 000 km (12 000 mile)	24 000 km (15 000 mile)	30 000 km (20 000 mile)	36 000 km (24 000 mile)				
Spark plug - clean and gap †			•	•	•	•	•	•	•	•	•	•	•
Valve clearance - check †				•		•		•		•		•	
Air Suction valve - check †			•	•	•	•	•	•	•	•	•	•	•
Air cleaner element - clean † #				•		•		•		•		•	
Throttle grip play - check †		•		•		•		•		•		•	
Idle speed - check †		•		•		•		•		•		•	
Carburetor synchronization - check †				•		•		•		•		•	
Evaporative emission control system (CA) - check †		•	•	•	•	•	•	•	•	•	•	•	•
Engine oil - change #	6 months	•	•	•	•	•	•	•	•	•	•	•	•
Oil filter - replace		•		•		•		•		•		•	
Drive chain wear - check † #			•	•	•	•	•	•	•	•	•	•	•
Brake pad wear - check † #			•	•	•	•	•	•	•	•	•	•	•
Brake light switch - check †		•	•	•	•	•	•	•	•	•	•	•	•
Steering - check †		•	•	•	•	•	•	•	•	•	•	•	•
Front fork oil - change	2 years							•					
Rear shock absorber oil leak - check †				•		•		•		•		•	
Front fork oil leak - check †				•		•		•		•		•	
Tire wear - check †			•	•	•	•	•	•	•	•	•	•	•
Swingarm pivot, uni-trak linkage - lubricate				•		•		•		•		•	
General lubrication - perform				•		•		•		•		•	
Nuts, bolts, and fasteners tightness - check †		•		•		•		•		•		•	
Drive chain - lubricate #	600 km		•	•	•	•	•	•	•	•	•	•	•
Drive chain slack - check † #	1000 km	•	•	•	•	•	•	•	•	•	•	•	•
Brake fluid level - check †	month	•	•	•	•	•	•	•	•	•	•	•	•
Clutch fluid level - check †	month	•	•	•	•	•	•	•	•	•	•	•	•
Radiator hoses, connection - check †		•											
Brake fluid - change	2 years							•					
Brake master cylinder cup and dust seal - replace	4 years												
Coolant - change	2 years							•					
Caliper piston seal and dust seal - replace	4 years												
Steering stem bearing - lubricate	2 years							•					
Clutch fluid - change	2 years							•					
Clutch master cylinder cup and seal - replace	4 years												
Clutch slave cylinder piston seal - replace	4 years												

# : Service more frequently when operating in severe conditions; dusty, wet, muddy, high speed, or frequent starting/stopping.

\* : For higher odometer readings, repeat at the frequency interval established here.

† : Replace, add, adjust, clean, or torque if necessary.

(CA): California Model only

Technical Information - Maintenance Free Battery

A maintenance free battery is installed in this model. The maintenance free battery is a sealed type, and so the electrolyte level check and topping-up cannot be performed.

(I) Construction

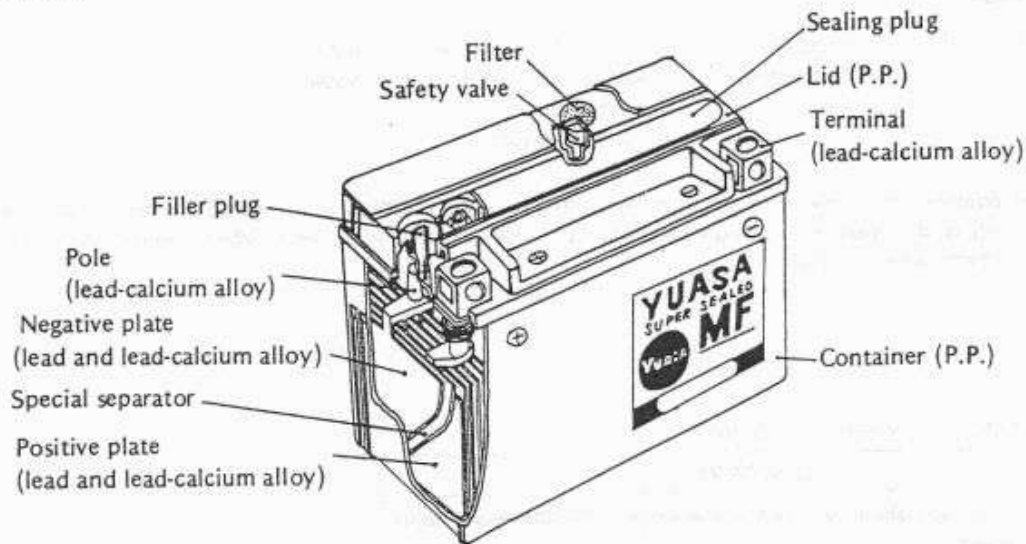

(II) Main Features

- 1) Maintenance free..... It is not necessary to check the electrolyte level and top-up the electrolyte.
- 2) No electrolyte leakage..... As the electrolyte is retained firmly in the special separators, there is no free electrolyte in the battery.
- 3) Instant activation system..... It can be used instantly after filling only the electrolyte without initial charge.
- 4) One-push motion electrolyte filling..... It is possible to fill the electrolyte by easy one-push motion.
- 5) Safety construction ..... If the battery internal pressure rises abnormally high, the safety valve opens to release the gas inside the battery to restore the normal pressure and prevent the battery from rupturing. After restoring the normal pressure, the safety valve closes and the battery is sealed again. Moreover, a ceramic filter is disposed on top of the safety valve under the lid to remove risk of ignition or explosion caused by fire from outside.
- 6) Compact and high performance ..... No presence of free electrolyte allows the battery made lower in height, thus resulting in enhanced volume efficiency. Moreover, gas being absorbed inside the battery eliminates the need for a gas exhaust tube.
- 7) Strong charge/discharge characteristics .... It can amply withstand deep charge/discharge cycles.

(III) Principle of Sealing Structure

A lead-acid battery operates under the following chemical reaction:

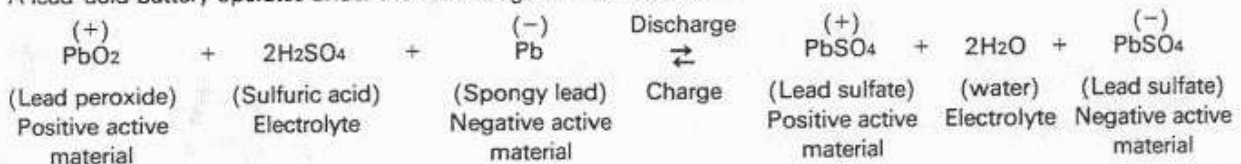

Normally in an ordinary lead-acid battery when it comes to an end of a charge, where the lead sulfate being a discharge product returns to lead peroxide and spongy lead, the charge current flowing thereafter is used exclusively to decompose electrolytically water from the electrolyte, thus resulting in generation of hydrogen gas from the negative plate and oxygen gas from the positive plate. The gases so generated are released out of the battery, causing the amount of electrolyte decreased to require occasional water replenishment.

A maintenance free battery, however, is so designed that, when it is overcharged, even if the positive plate is fully charged, the negative plate remains not fully turned to spongy lead. Therefore, even when the positive plate is overcharged generating oxygen gas, the negative plate is not fully charged, hence generating no hydrogen gas.

Moreover, the oxygen gas generated from the positive plate immediately reacts with the charged active material on the negative plate, and returns to water, with the ultimate result of no water loss.

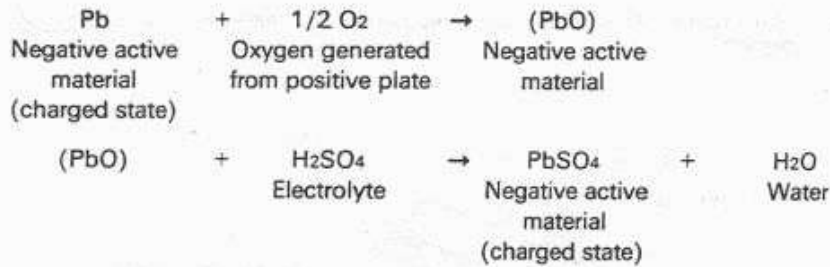

Thus, the negative plate is made as not to get fully charged. Even if the overcharge continues, the oxygen gas generated inside the battery is absorbed by the negative plate, a process called oxygen cycle, which theoretically prevents water loss, and allows the battery to be sealed.

#### (IV) Filling the Battery with Electrolyte

##### CAUTION

Do not remove the aluminum seal sheet sealing the filler ports until just before use.  
Be sure to use the dedicated electrolyte container for correct electrolyte volume.

- Check to see that there is no peeling, tears or holes in the sealing sheet.
- Place the battery on a level surface.
- Remove the sealing sheet [A].
- When removing, check to hear an air-sucking sound "Shoosh!" from filler ports [B].

##### NOTE

○ A battery whose sealing sheet has any peeling, tears, holes, or from which the air-sucking sound was not heard requires a refreshing charge (initial charge).

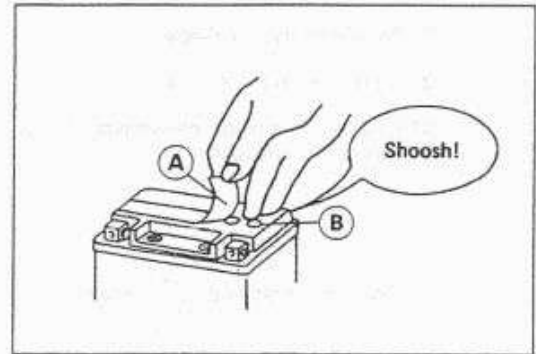

- Take the electrolyte container out of the vinyl bag.
- Detach the strip of caps [A] from the container.

##### NOTE

○ Do not discard the strip of caps because it is used as the battery plugs later.  
○ Do not peel back or pierce the sealed areas [B].

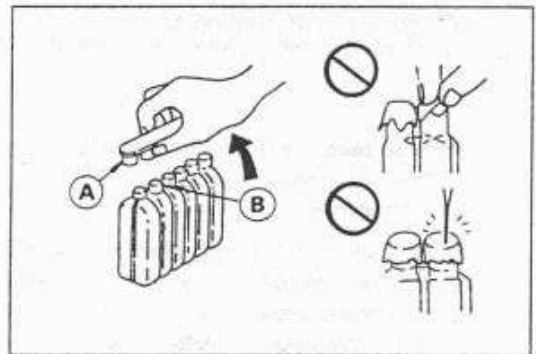

- Place the electrolyte container upside down with the six sealed areas in line with the six battery filler ports.
- Push the container down strongly enough to break the seals. Now the electrolyte should start to flow into the battery.

##### NOTE

○ Do not tilt the container as the electrolyte flow may be interrupted.

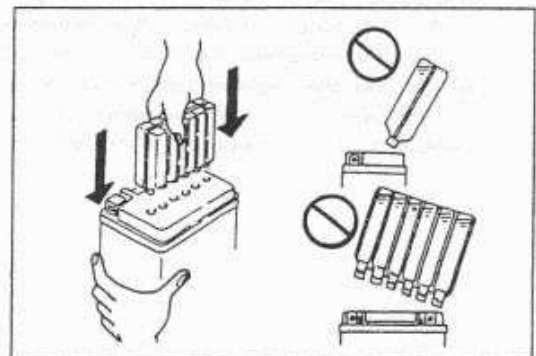

- Make sure air bubbles [A] are coming up from all six filler ports.
- Leave the container this way for 5 minutes or longer.

**NOTE**

○ If no air bubbles are coming up from a filler port, tap the bottom of the bottle two or three times. Never remove the container from the battery.

**CAUTION**

Fill until the container is completely emptied.

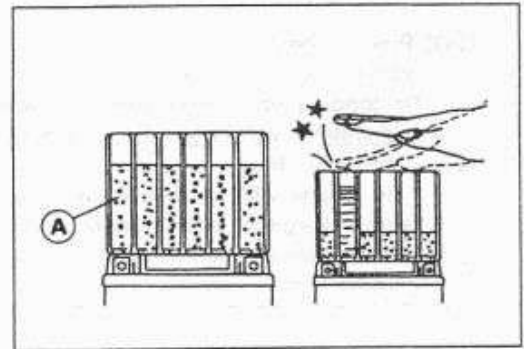

- Be certain that all the electrolyte has flowed out.
- Tap the bottom the same way as above if there is any electrolyte left in the container.
- Now pull the container gently out of the battery.
- Let the battery sit for 20 minutes. During this time, the electrolyte permeates the special separators and the gas generated by chemical reaction is released.
- Fit the strip of caps [A] tightly into the filler ports until the strip is at the same level as the top of the battery.

**NOTE**

○ Do not hammer. Press down evenly with both hands.

**CAUTION**

Once you install the strip of caps after filling the battery, never remove it, nor add any water or electrolyte.

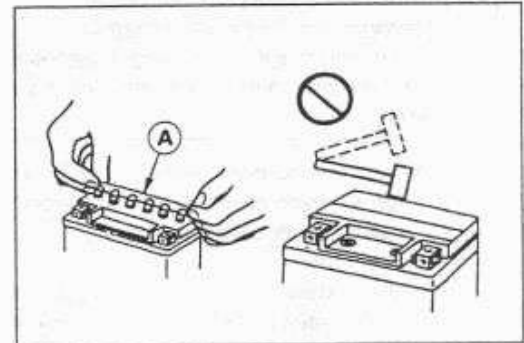

**(V) Initial Charge**

While a maintenance free battery can be used after only filling with electrolyte, a battery may not be able to sufficiently move a starter motor to start an engine in the cases shown in the table below, where an initial charge is required before use. However, if a battery shows a terminal voltage of higher than 12.5 V after 10 minutes of filling (Note 1), no initial charge is necessary.

Condition requiring initial charge	Charging method
At low temperatures (lower than 0°C)	(N) 0.9 A × 2 ~ 3 hours (P) 1.2 A × 2 ~ 3 hours
Battery has been stored in high temperature and humidity.	(N) 0.9 A × 15 ~ 20 hours (P) 1.2 A × 15 ~ 20 hours
Seal has been removed, or broken – peeling, tear or hole. (If you did not hear the air-sucking sound “Shoosh!” as you removed the seal.)	
Battery as old as 2 years or more after manufacture. Battery manufacturing date is printed on battery top. Example) $\frac{12}{\text{Day}}$ $\frac{10}{\text{Month}}$ $\frac{93}{\text{Year}}$ $\frac{T1}{\text{Mfg. location}}$	

Note 1 : Terminal voltage – To measure battery terminal voltage, use a digital voltmeter.  
(N): ZX750N                      (P): ZX750P

### (VI) Precautions

- 1) No need of topping-up  
No topping-up is necessary in this battery until it ends its life under normal use. Forcibly prying off the sealing plug to add water is very dangerous. Never do that.
  - 2) Refreshing charge  
If an engine will not start, a horn sounds weak, or lamps are dim, it indicates the battery has been discharged. Give refresh charge for 5 to 10 hours with charge current shown in the specification (see the Electrical System chapter).  
When a fast charge is inevitably required, do it following precisely the maximum charge current and time conditions indicated on the battery.
- CAUTION**

This battery is designed to sustain no unusual deterioration if refresh-charged according to the method specified above. However, the battery's performance may be reduced noticeably if charged under conditions other than given above. Never remove the sealing plug during refresh charge.  
If by chance an excessive amount of gas is generated due to overcharging, the safety valve operates to keep the battery safe.
- 3) When you do not use the motorcycle for months  
Give a refresh charge before you store the motorcycle and store it with the negative lead removed. Give a refresh charge **once a month** during storage.
  - 4) Battery life  
If the battery will not start the engine even after several refresh charges, the battery has exceeded its useful life. Replace it. (Provided, however, the vehicle's starting system has no problem.)

### **▲WARNING**

Keep the battery away from sparks and open flames during charging, since the battery gives off an explosive gas mixture of hydrogen and oxygen. When using a battery charger, connect the battery to the charger before turning on the charger. This procedure prevents sparks at the battery terminals which could ignite any battery gases.  
No fire should be drawn near the battery, or no terminals should have the tightening loosened.  
The electrolyte contains sulfuric acid. Be careful not to have it touch your skin or eyes. If touched, wash it off with liberal amount of water. Get medical attention if severe.

### (VII) Interchangeability with Ordinary Battery

A maintenance free battery can fully display its performance only when combined with a proper vehicle electric system. Therefore, replace a maintenance free battery only on a motorcycle which was originally equipped with a maintenance free battery.

Be careful, if a maintenance free battery is installed on a motorcycle which had an ordinary battery as original equipment, the maintenance free battery's life will be shortened.



Technical Information – Flat CR Slide Carburetor

The ZX750N has flat slide carburetors.

**Throttle Mechanism:**

The slides are Teflon coated and two rollers are located on each side of the slide to reduce friction. The rollers are mounted on shielded ball bearings and the throttle shaft on sealed needle bearings.

- [A] Needle Bearing
- [B] Plastic Roller
- [C] Shielded Ball Bearing
- [D] Slide

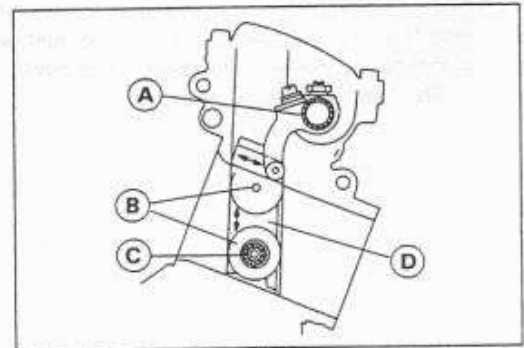

The resulting reduction in effort to move the slides gives the rider very precise throttle control.

The throttle links open the throttle valves progressively. This makes engine control easier at low and mid-range and vehicle control easier when riding on tight corners or wet roads.

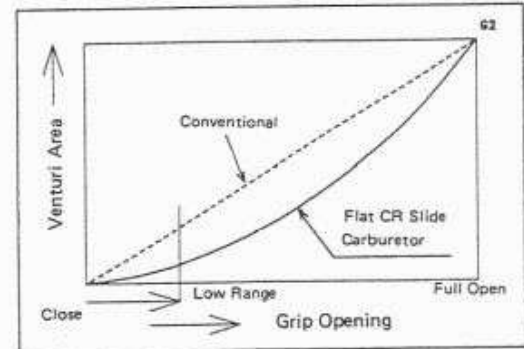

**Accelerator Pumps:**

Air, being lighter than fuel, accelerates away from the fuel when the throttle valve is quickly opened. When the air arrives at the combustion chamber, there is not enough fuel with it and a lean stumble or hesitation results. This is especially true of large-bore carburetors such as on the ZX750N. To combat this, the "CR" carburetors have two diaphragm-type accelerator pumps which shoot a stream of fuel down each venturi toward the intake valves. This supplies an enriched fuel mixture that arrives at the combustion chamber with the air.

When the throttle is suddenly opened, the pump rod linked to the throttle shaft pushes the pump diaphragm forcing the fuel from the pump chamber. The inlet check valve closes and the outlet check valve opens allowing fuel to spray from the discharge nozzle. As the diaphragm relaxes, the inlet valve opens letting fuel from the float bowl refill the pump chamber. The outlet check valve closes as accelerator pump pressure falls stopping fuel from syphoning out the discharge nozzle.

- [A] Pump Rod
- [B] Pump Diaphragm
- [C] Pump Chamber
- [D] Inlet Check Valve
- [E] Outlet Check Valve
- [F] Discharge Nozzle

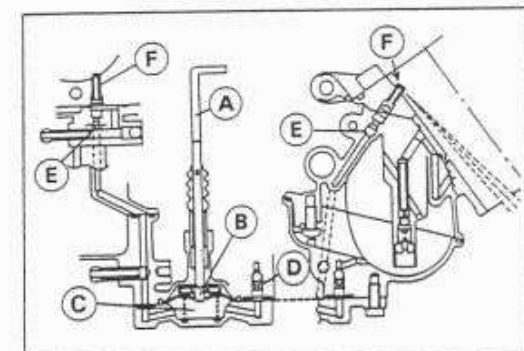
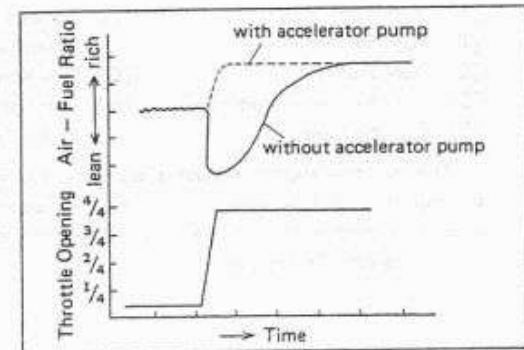

**Fuel Enricher:**

The fuel enricher provides a richer mixture to the engine in order to improve throttle response at lower engine speeds and prevent misfiring when the throttle is quickly opened.

When the throttle is more than 3/8 - open and the engine is turning between 1 500 rpm and 5 000 rpm, the fuel enricher solenoid valve opens and pressured fuel is available to the accelerator pump chamber.

The accelerator pump inlet check valve closes preventing enricher fuel from flooding the float bowl. Instead, fuel passes through the accelerator pump outlet check valve and out the discharge nozzle.

The fuel flows as shown.

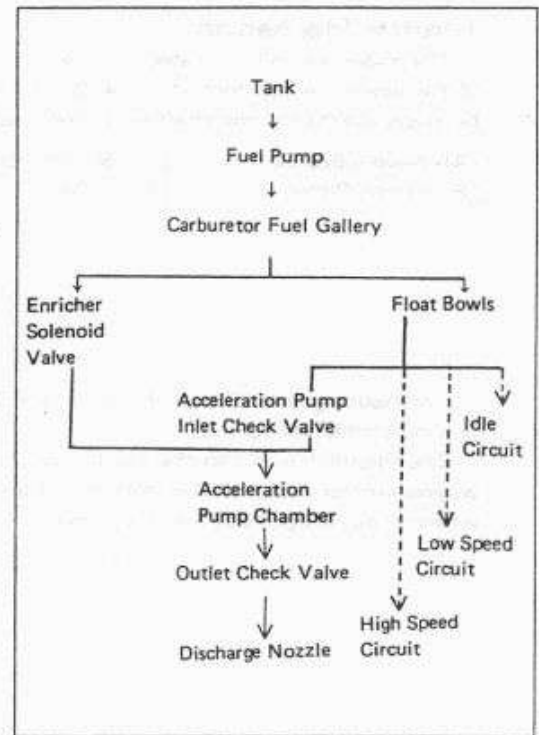
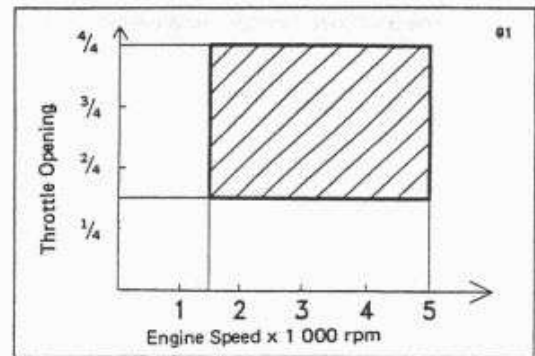

- |                             |                               |
|-----------------------------|-------------------------------|
| [A] Fuel Tank               | [F] Accelerator Pump Chambers |
| [B] Fuel Pump               | [G] Discharge Nozzles         |
| [C] Fuel Gallery            | [H] Throttle Switch           |
| [D] Enricher Solenoid Valve | [I] IC Igniter                |
| [E] Enricher Jet            |                               |

The throttle switch sends a signal to the IC igniter when the throttle is more than 3/8 - open. The IC igniter senses the throttle switch signal and engine speed, and actuates the fuel enricher solenoid valve according to the conditions above.

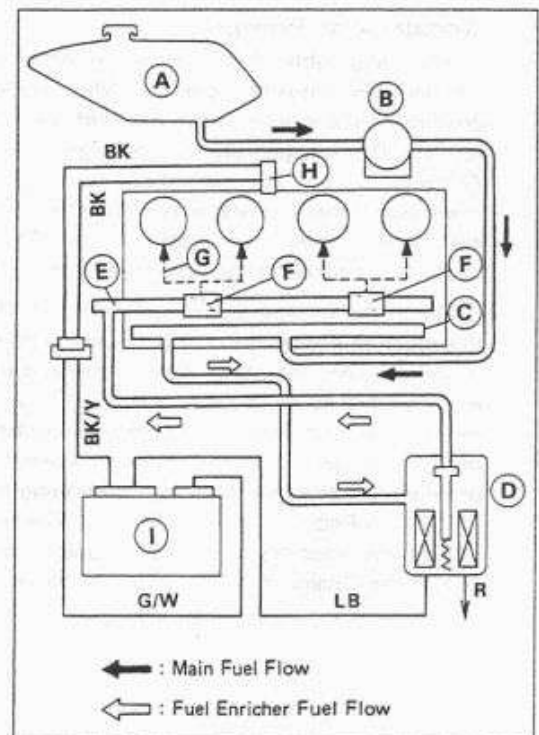

## Technical Information – Side Camshaft Chain

Positioning the cam chain on the right side of the cylinders enables all of the combustion paths from the airbox to the exhaust pipe to be short and straight as shown, improving breathing efficiency and shortening the cylinder block.

It shortens the crankshaft and improves its rigidity.

It also allows the crankshaft camchain sprocket to be as small as possible, without effecting crankshaft strength. This permits the camshaft sprockets to be as small as possible also, allowing the cylinder head to be compact. The compact cylinder head reduces engine weight and provides more freedom in the design of the frame.

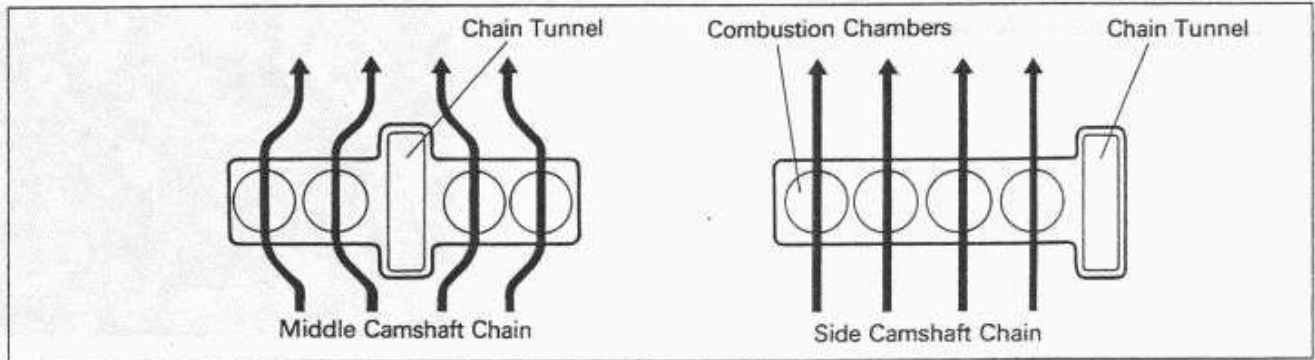

## 1-20 GENERAL INFORMATION

### Technical Information - Engine Lubrication System

The ZX750N/P oil system has dual oil pumps, with one pump (Sub-Oil Pump Rotor) [A] feeding pressurised oil to the oil cooler and the other (Main Oil Pump Rotor) [B] to the top end, crank, and transmission. However, the main oil pump rotor width, at a mere 14 mm, significantly reduces mechanical loss. This two-pump system helps ensure reliable lubrication by avoiding drops in oil pressure during extreme riding conditions.

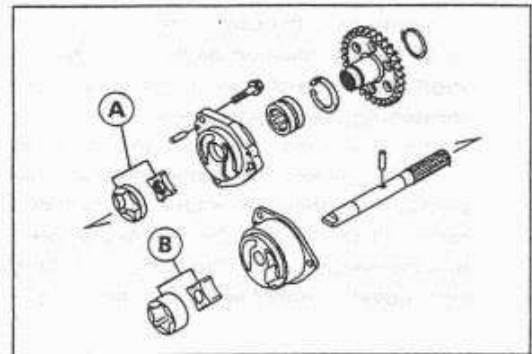

To cool the oil, a liquid-cooled oil cooler [A] is employed, which offers several advantages over the air-cooled type.

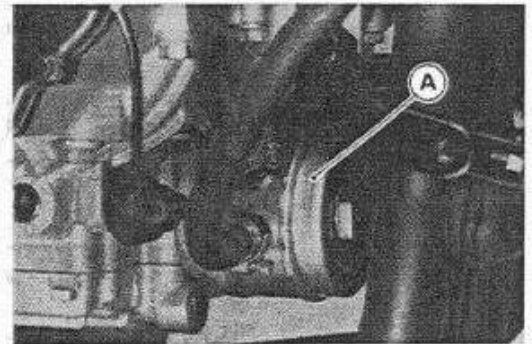

First, having almost the same cooling capability, the liquid-cooled oil cooler is more compact than the air-cooled oil cooler, fitted easily in the engine, and helps easy maintenance of engine. Next, since the cooler is installed right on the crankcase without oil hoses, there is little chance of a major oil leak and little oil pressure drop in the cooler.

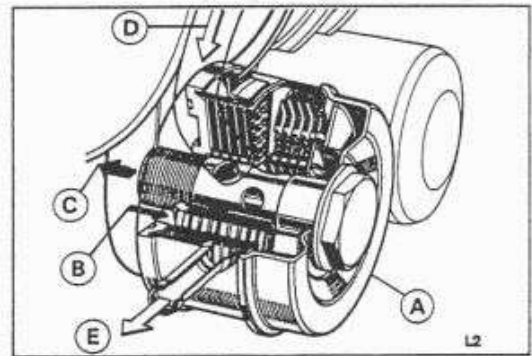

- [A] Liquid-cooled Oil Cooler
- [B] Hot Oil
- [C] Cold Oil
- [D] Cold Coolant
- [E] Hot Coolant

The semi-dry sump system is designed to reduce oil stirring loss by keeping the oil from collecting in the crankcase below the crankshaft and in the clutch. Baffles [A] and passages [B] are fitted in the crankcase below the transmission to collect the oil at once as it returns from the lubrication system, feeding it to the oil pump inlet [C] and away from the crankcase and clutch basket.

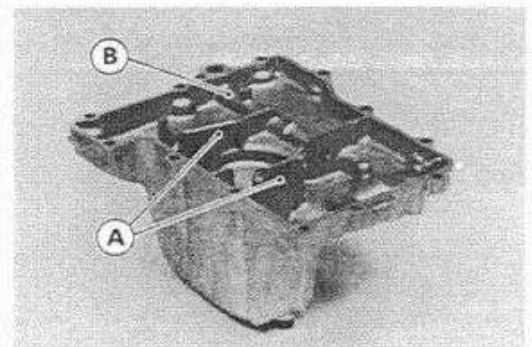
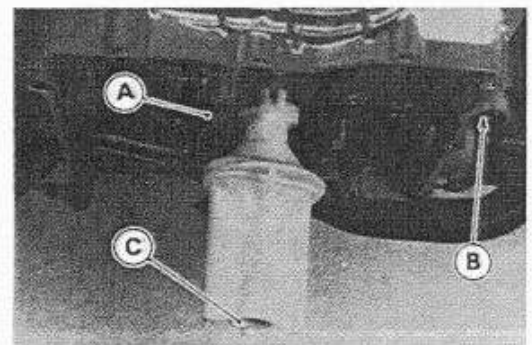

## Technical Information – Connecting Rod Big End Nut Tightening

### Benifits:

There are two methods for tightening connecting rod big end nuts: **the elastic region fastening method** and **the plastic region fastening method**. With the elastic region fastening method, bolt axial tension increases in proportion to nut rotation angle (bolt strain) when the nut is tightened. Upon removal of torque, the bolt returns to its original length.

The elastic region fastening method has been widely used because it is simple and the bolts can be retightened and reused.

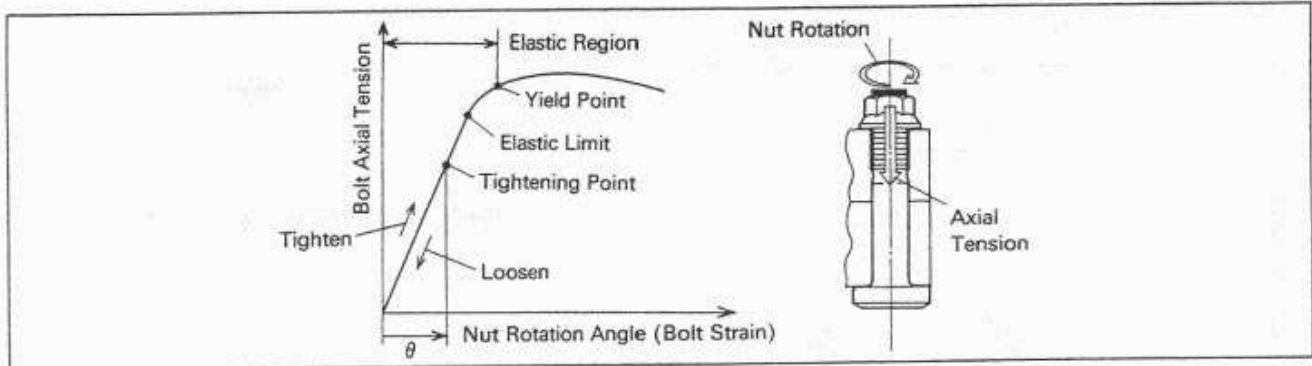

However, the ZX750N/P use the plastic region fastening method for reduced connecting rod weight and increased fastening reliability. This is because the ZX750N/P's connecting rods are under very severe conditions such as high engine speed and high horsepower.

With the plastic region fastening method, the bolt is tightend beyond its yield point where bolt strain grows rapidly. Upon removal of torque, the bolt doesn't return to original length any more and permanent strain remains.

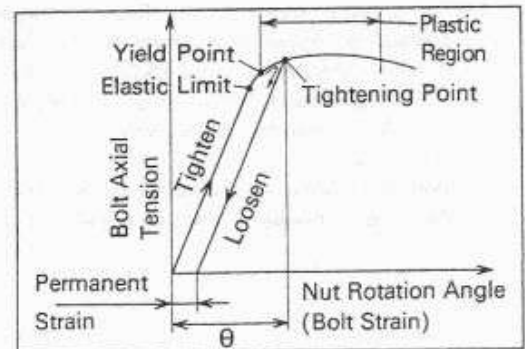

Beyond the yield point, axial tension increases gradually compared to bolt strain : axial tension varies less to variations of nut rotation angle than in the elastic region as shown. Here, axial tension corresponds to clamping force (the actual pressure applied to the two parts being bolted together), and bolt strain corresponds to nut rotation angle or to tightening torque.

From this, the plastic region fastening method provides more stable and higher axial tension. But the method is more sophisticated than conventional torquing and requires precise assembly and disassembly procedures.

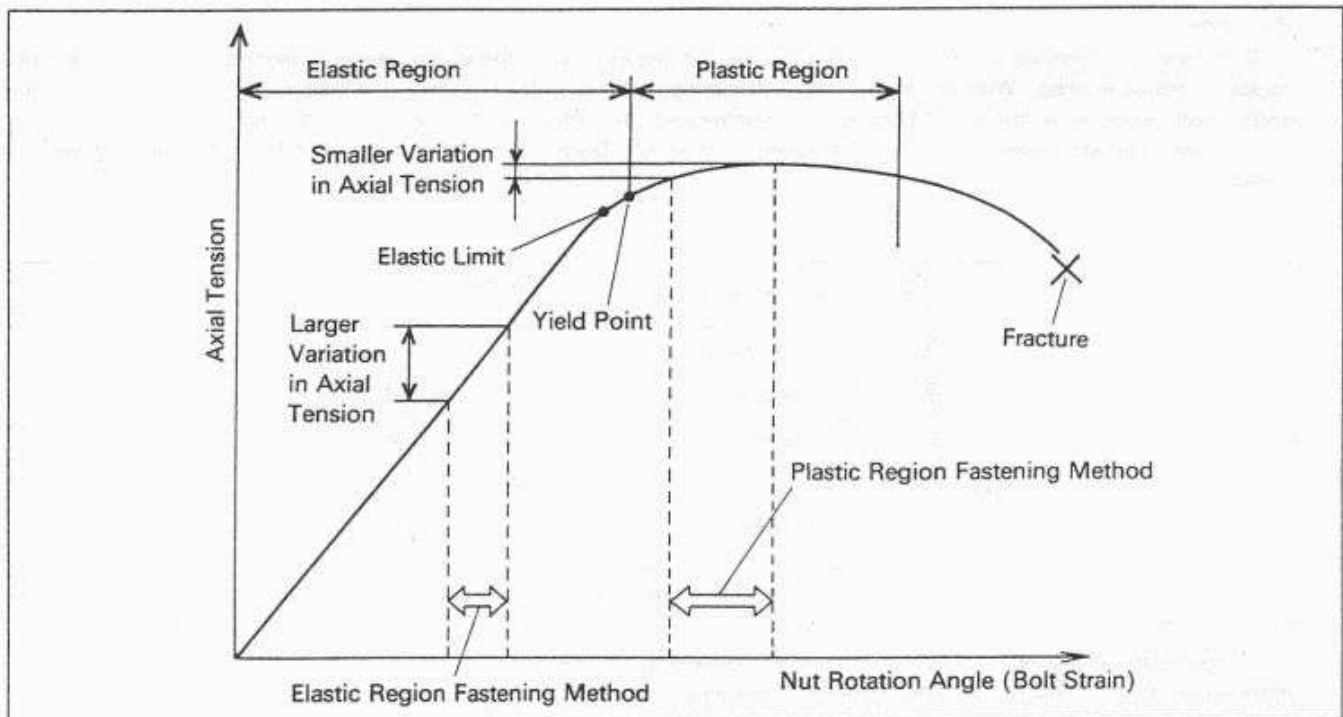

**Work Notes:**

- Be sure to clean the bolts, nuts, and connecting rods thoroughly with high-flash point solvent, because the new connecting rods, bolts, and nuts are treated with an anti-rust solution. This solution contains hydrogen which could weaken high tensile bolts such as connecting rod bolts and lead to bolt breakage.
- Apply molybdenum disulfide grease to the upper inner surface of the connecting rod big end. This prevents the upper bearing insert from wear and corrosion from its slight sliding motion during operation.
- Do not apply molybdenum disulfide grease, only engine oil to the inner surface of upper and lower bearing inserts because molybdenum disulfide grease promotes sliding motion of bearing inserts.
  - [A] Apply molybdenum disulfide grease
  - [B] Do not apply grease and oil
  - [C] Apply oil
- With the plastic region fastening method, do not retighten and reuse the bolts or the permanent strain accumulates and the bolts may break.

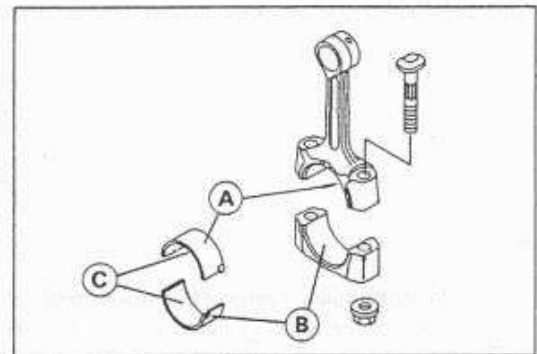

**Methods:**

- There are two methods of plastic region fastening. One is a **bolt length measurement method** and the other is a **rotation angle method**. Use one of the following two.
  - (1) Bolt Length Measurement Method
- This method is preferable because this is a more reliable way to tighten the big end nuts, though it requires a point micrometer [A] and cumbersome work.
  - [B] Connecting Rod
  - [C] Mark here with a punch
  - [D] Nuts
  - [E] Fit micrometer pins into punch marks
- To prevent seizure of the bolt threads, apply a small amount of engine oil to the threads.

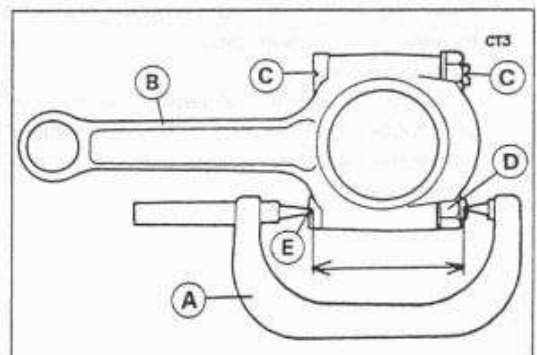

## (2) Rotation Angle Method

- First, apply a small amount of engine oil to the threads [A] and seating surface [B] of the nuts to get stable axial tension.

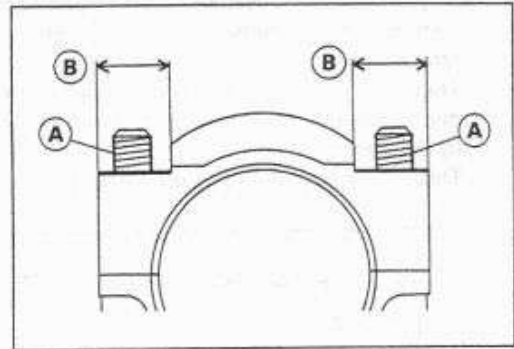

- Next, tighten the nuts to the specified torque (snug torque) to seat the threads and mating surfaces.

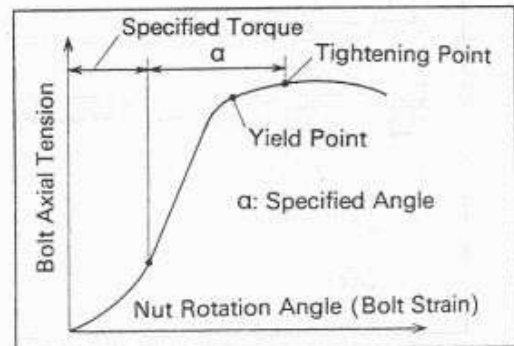

- Finally, tighten the nuts the specified angle  $\alpha^\circ$  to exceed the yield point.

- [A] Crankshaft
- [B] Connecting Rod Big End Nuts
- [C]  $\alpha^\circ$

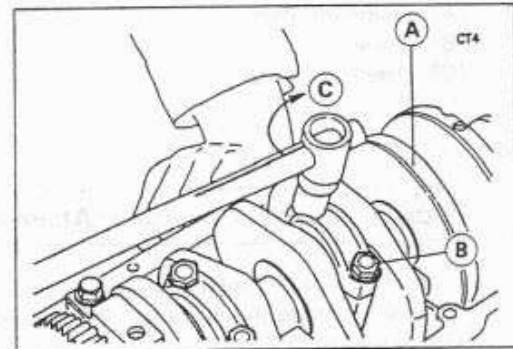

## 1-24 GENERAL INFORMATION

### Technical Information - Swingarm

The swingarm pivots are equipped with low-friction needle bearings for smooth working. On the rightside is a ball bearing which supports the thrust loads and eliminates even slight lateral play of the swingarm. This strengthens swingarm rigidity, especially its torsional rigidity, offering the motorcycle easier and smoother drive under severe riding conditions. The pivot parts are tightened against the frame in this order: the collar [B] and pivot shaft [E], the pivot nut [G], and the pivot locknut [A], so the pivot shaft [E] and ball bearing [F] can be installed without any frame deformation and any gap to the frame.

This prevents scraping of the seating surfaces and possible gaps among the aluminum pivot parts.

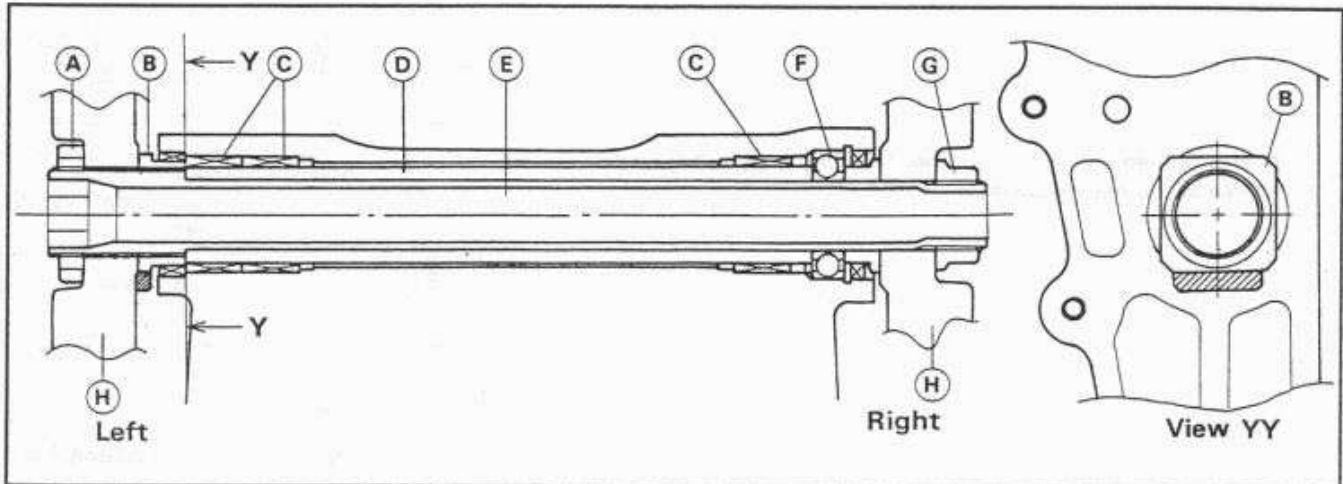

[A] Swingarm Pivot Locknut  
[B] Collar  
[C] Needle Bearings

[D] Sleeve  
[E] Swingarm Pivot Shaft  
[F] Ball Bearing

[G] Swingarm Pivot Nut  
[H] Frame

### Technical Information - Alternator Unit

An alternator [A] with a regulator/rectifier built in is mounted on the crankcase, behind the cylinder. The conventional alternator is installed on the crankshaft end.

Benefits are as follows: Shortened engine width offers larger banking angle and smaller inertia when turning the motorcycle. The alternator output is increased comparing with the conventional alternator owing to increased alternator capacity itself, increased alternator speed over the crankshaft speed, and the alternator cooling fan.

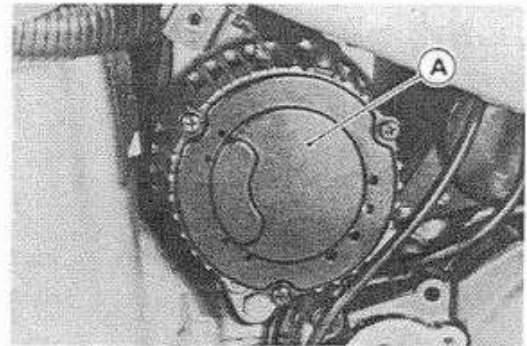



**Torque and Locking Agent**

The following tables list the tightening torque for the major fasteners requiring use of a non-permanent locking agent or liquid gasket.

Letters used in the "Remarks" column mean:

- L** : Apply a non-permanent locking agent to the threads.
- LG** : Apply liquid gasket to the threads.
- Lh** : Left-hand threads.
- M** : Apply molybdenum disulfide grease.
- O** : Apply an oil to the threads and seating surface.
- G** : Apply grease.
- S** : Tighten the fasteners following the specified sequence.
- SS** : Apply silicone sealant.
- St** : Stake the fasteners to prevent loosening.
- R** : Replacement parts

The table below, relating tightening torque to thread diameter, lists the basic torque for the bolts and nuts. Use this table for only the bolts and nuts which do not require a specific torque value. All of the values are for use with dry solvent-cleaned threads.

**Basic Torque for General Fasteners**

Threads dia. (mm)	Torque		
	N-m	kg-m	ft-lb
5	3.4 ~ 4.9	0.35 ~ 0.50	30 ~ 43 in-lb
6	5.9 ~ 7.8	0.60 ~ 0.80	52 ~ 69 in-lb
8	14 ~ 19	1.4 ~ 1.9	10.0 ~ 13.5
10	25 ~ 34	2.6 ~ 3.5	19.0 ~ 25
12	44 ~ 61	4.5 ~ 6.2	33 ~ 45
14	73 ~ 98	7.4 ~ 10.0	54 ~ 72
16	115 ~ 155	11.5 ~ 16.0	83 ~ 115
18	165 ~ 225	17.0 ~ 23.0	125 ~ 165
20	225 ~ 325	23 ~ 33	165 ~ 240

Fastener	Torque			Remarks
	N-m	kg-m	ft-lb	
<b>Fuel System:</b> Vacuum Valve Drain Screw	1.0	0.10	9 in-lb	
<b>Cooling System:</b> Water Hose Clamp Screws	2.5	0.25	22 in-lb	
Water Pipe Bolt (Water Pump)	9.8	1.0	87 in-lb	
Coolant Air Bleeder Bolt (Water Pump)	9.8	1.0	87 in-lb	
Coolant Drain Plug (Water Pump)	9.8	1.0	87 in-lb	
Water Hose Fitting Bolts (Cylinder)	9.8	1.0	87 in-lb	
Radiator Fan Switch	18	1.8	13.0	SS
Water Temperature Sensor	15	1.5	11.0	SS
Water Pump Cover Bolts	9.8	1.0	87 in-lb	
<b>Engine Top End:</b> Spark Plugs	13	1.3	113 in-lb	
Air Suction Valve Cover Bolts	9.8	1.0	87 in-lb	
Cylinder Head Cover Bolts	9.8	1.0	87 in-lb	
Pickup Coil Cover Bolts	9.8	1.0	87 in-lb	L
Camshaft Chain Tensioner Mounting Bolts	12	1.2	104 in-lb	L
Camshaft Cap Bolts	12	1.2	104 in-lb	S
Water Pipe Flange Bolts (Cylinder Head)	12	1.2	104 in-lb	
Water Hose Fitting Bolts (Cylinder)	9.8	1.0	87 in-lb	
Cylinder Head Bolts: M10	44	4.5	33	S, O (Washer)
M6	12	1.2	104 in-lb	S
Engine Damper Cover Bolts	9.8	1.0	87 in-lb	L
Rear Camshaft Chain Guide Bolt	25	2.5	18.0	
Inlet Pipe Fittings	4.9	0.50	43 in-lb	
Inlet Pipe Plugs	4.9	0.50	43 in-lb	
Carburetor Holder Bolts	12	1.2	104 in-lb	
Oil Pipe Bolt	9.8	1.0	87 in-lb	

Fastener	Torque			Remarks
	N-m	kg-m	ft-lb	
<b>Clutch</b>				
Clutch Lever Pivot Bolt	1.0	0.10	9 in-lb	
Clutch Lever Pivot Bolt Locknut	5.9	0.60	52 in-lb	
Starter Lockout Switch Screws	1.0	0.10	9 in-lb	
Clutch Slave Cylinder Bleed Valve	7.8	0.80	69 in-lb	
Clutch Reservoir Cap Screws	1.5	0.15	13 in-lb	
Clutch Master Cylinder Clamp Bolts	11	1.1	95 in-lb	S
Oil Filler Plug	1.5 or Hand-Tight	0.15 or Hand-Tight	13 in-lb or Hand-Tight	
Clutch Cover Bolts	9.8	1.0	87 in-lb	L(3, Front)
Clutch Cover Damper Bolts	5.9	0.60	52 in-lb	L
Clutch Hub Bolts	25	2.5	18.0	L
Clutch Spring Bolts	8.8	0.90	78 in-lb	
Clutch Hub Nut	130	13.5	98	R
Clutch Housing Bolts	7.8	0.80	69 in-lb	L
Clutch Hose Banjo Bolts	25	2.5	18.0	
<b>Engine Lubrication System:</b>				
Oil Filler Plug	1.5 or Hand-Tight	0.15 or Hand-Tight	13 in-lb or Hand-Tight	
Engine Drain Plug	20	2.0	14.5	
Oil Filter(Cartridge type)	9.8 or Hand-Tight	1.0 or Hand-Tight	87 in-lb or Hand-Tight	R,G(O- ring)
Oil Filter Mounting Bolt	25	2.5	18.0	L(Tap End)
Oil Pan Bolts	9.8	1.0	87 in-lb	
Oil Pressure Relief Valves	15	1.5	11.0	L
Oil Pressure Switch Terminal Bolt	1.5	0.15	13 in-lb	
Oil Pressure Switch	15	1.5	11.0	SS
Oil Pump Bolts	12	1.2	104 in-lb	L
Oil Cooler Bolt	49	5.0	36	O
Oil Hose Clamp Screws	2.5	0.25	22 in-lb	
Oil Pipe Flange Bolts	9.8	1.0	87 in-lb	
Crankcase Main Oil Passage Plugs	20	2.0	14.5	SS
Alternator Shaft Oil Pipe Bolt	12	1.2	104 in-lb	L
Transmission Oil Pipe Holder Bolt (Right Side)	12	1.2	104 in-lb	L
<b>Engine Removal/Installation:</b>				
Engine Collar Bolts	9.8	1.0	87 in-lb	
Engine Mounting Locknuts	49	5.0	36	
Engine Mounting Bolts and Nuts	59	6.0	43	
<b>Crankshaft/Transmission:</b>				
Upper Alternator Chain Tensioner Pivot Bolt	12	1.2	104 in-lb	L
Upper Alternator Chain Tensioner Set Bolt	12	1.2	104 in-lb	L
Upper Chain Tensioner Locknut	25	2.5	18.0	
Alternator Shaft Oil Pipe Bolt	12	1.2	104 in-lb	L
Lower Alternator Chain Tensioner Bolts	12	1.2	104 in-lb	L

Fastener	Torque			Remarks
	N-m	kg-m	ft-lb	
Alternator Shaft Bearing Holder Bolts	12	1.2	104 in-lb	L
Alternator Shaft Bolt	25	2.5	18.0	
Camshaft Chain Guide Bolt	25	2.5	18.0	
Lower Crankcase Bolts $\phi$ 9	44	4.5	33	
$\phi$ 8 (115mm)	27	2.8	20	
$\phi$ 8 (40mm, 45mm)	25	2.5	18.0	
Upper Crankcase Bolts $\phi$ 8	25	2.5	18.0	
Engine Breather Cover Bolts	9.8	1.0	87 in-lb	L
Crankcase Main Oil Passage Plugs	20	2.0	14.5	SS
Transmission Oil Pipe Bolt (Right Side)	12	1.2	104 in-lb	L
Connecting Rod Big End Nuts	in the text	←	←	←
Battery Negative Lead Terminal Bolt	4.9	0.50	43 in-lb	
Oil Pipe Flange Bolts	9.8	1.0	87 in-lb	
Timing Rotor Bolt	25	2.5	18.0	
Starter Clutch Holder Bolts	12	1.2	104 in-lb	L
External Shift Mechanism Cover Screws	4.9	0.50	43 in-lb	L
External Shift Mechanism Cover Bolts	9.8	1.0	87 in-lb	
Gear Positioning Lever Bolt	9.8	1.0	87 in-lb	L
Shift Shaft Return Spring Pin (Bolt)	42	4.3	31	L
Neutral Switch Screw	3.9	0.40	35 in-lb	
Shift Drum Bearing Holder Bolts	12	1.2	104 in-lb	L
Shift Drum Cam Holder Bolt	12	1.2	104 in-lb	L
Pickup Coil Cover Bolts	9.8	1.0	87 in-lb	L
<b>Wheels/Tires:</b>				
Front Axle Clamp Bolts	20	2.0	14.5	
Front Axle Nut	145	15.0	110	
Rear Axle Nut	145	15.0	110	
<b>Final Drive:</b>				
Engine Sprocket Cover Bolts	9.8	1.0	87 in-lb	
Engine Sprocket Nut	125	13.0	94	0
Rear Sprocket Nuts	74	7.5	54	
Rear Sprocket Studs	-	-	-	L
Rear Axle Nut	145	15.0	110	
<b>Brakes:</b>				
Bleed Valves (ZX750N)	5.4	0.55	48 in-lb	
Bleed Valves (ZX750P)	7.8	0.80	69 in-lb	
Brake Hose Banjo Bolts	25	2.5	18.0	
Brake Lever Pivot Bolt	1.0	0.10	9 in-lb	
Brake Lever Pivot Bolt Locknut	5.9	0.60	52 in-lb	
Front Brake Reservoir Cap Holder Screws	1.5	0.15	13 in-lb	
Front Brake Light Switch Screws	1.0	0.10	9 in-lb	
Front Master Cylinder Clamp Bolts	11	1.1	95 in-lb	S
Front Brake Hose Joint Mounting Bolts	6.9	0.70	61 in-lb	
Front Caliper Mounting Bolts	34	3.5	25	
Front Brake Disc Mounting Bolts	23	2.3	16.5	
Front Caliper Assembly Bolts (ZX750N)	23	2.3	16.5	L
Front Caliper Assembly Bolts (ZX750P)	21	2.1	15.0	
Front Brake Pad Pin (ZX750N)	18	1.8	13.0	
Front Brake Pad Pin Plug (ZX750N)	2.5	0.25	22 in-lb	
Front Brake Pad Spring Bolts (ZX750P)	2.9	0.30	26 in-lb	

Fastener	Torque			Remarks
	N-m	kg-m	ft-lb	
Rear Brake Reservoir Bolt	6.9	0.70	61 in-lb	
Rear Brake Hose Holder Bolts	6.9	0.70	61 in-lb	
Rear Brake Disc Mounting Bolts	23	2.3	16.5	
Rear Caliper Mounting Bolts	25	2.5	18.0	
Rear Master Cylinder Mounting Bolts	23	2.3	16.5	
Rear Master Cylinder Push Rod Locknut	18	1.8	13.0	
Rear Caliper Assembly Bolts (ZX750N)	32	3.3	24	L
Rear Caliper Assembly bolts (ZX750P)	29	3.0	22	
Rear Brake Pad Pin (ZX750N)	18	1.8	13.0	
Rear Brake Pad Pin Plug (ZX750N)	2.5	0.25	22 in-lb	
<b>Suspension:</b>				
Upper Front Fork Clamp Bolts	21	2.1	15.0	
Lower Front Fork Clamp Bolts (ZX750N)	21	2.1	15.0	
Lower Front Fork Clamp Bolts (ZX750P)	28	2.9	21	
Front Fork Top Plugs	23	2.3	16.5	
Piston Rod Nut	15	1.5	11.0	
Front Fork Bottom Allen Bolts	39	4.0	29	L
Front Axle Clamp Bolts	20	2.0	14.5	S
Rear Shock Absorber Nuts	59	6.0	43	
Rear Shock Absorber Upper Brackets Nut	59	6.0	43	
Swingarm Pivot Shaft	20	2.0	14.5	S
Swingarm Pivot Nut	98	10.0	72	S
Swingarm Pivot Locknut	98	10.0	72	S
Uni-Trak				
Rocker Arm Nuts	59	6.0	43	
Tie-Rod Nuts	59	6.0	43	
<b>Steering:</b>				
Steering Stem Head Nut	54	5.5	40	
Steering Stem Nut	4.9 or Hand-Tight	0.50 or Hand-Tight	43 in-lb or Hand-Tight	
Handlebar Bolts	34	3.5	25	L
Handlebar Holder Bolts	23	2.3	16.5	
Handlebar Holder Position Bolts	9.8	1.0	87 in-lb	L
Handlebar Weight Screws	-	-	-	L
Handlebar Switch Housing Screws	3.4	0.35	30 in-lb	
<b>Frame:</b>				
Rear Frame Bolts and Nuts	44	4.5	33	
Footpeg Holder Bolts (Right, Left)	34	3.5	25	L
Side Stand Bracket Bolts	49	5.0	36	
<b>Electrical System:</b>				
Spark Plugs	13	1.3	113 in-lb	
Alternator Mounting Bolts	25	2.5	18.0	
Alternator Coupling Nut	54	5.5	40	
Alternator Assembly Nuts	4.4	0.45	39 in-lb	
Alternator Bearing Retainer Screws	2.5	0.25	22 in-lb	Alternator Housing
Alternator Regulator Screws	3.4	0.35	30 in-lb	
Alternator Lead Terminal Screws	3.4	0.35	30 in-lb	
Alternator Brush Screws	3.4	0.35	30 in-lb	
Alternator Cover Screws	3.4	0.35	30 in-lb	
Pickup Coil Cover Bolts	9.8	1.0	87 in-lb	L
Pickup Coil Bolts	7.8	0.80	69 in-lb	

Fastener	Torque			Remarks
	N-m	kg-m	ft-lb	
Timing Rotor Bolt	25	2.5	18.0	
Starter Motor Terminal Locknut	11	1.1	95 in-lb	
Starter Motor Terminal Nut	4.9	0.50	43 in-lb	
Starter Relay Terminal Bolt	4.9	0.50	43 in-lb	
Starter Motor Through Bolts	5.9	0.60	52 in-lb	
Starter Motor Mounting Bolts	9.8	1.0	87 in-lb	
Handlebar Switch Housing Screws	3.4	0.35	30 in-lb	
Radiator Fan Switch	18	1.8	13.0	SS
Water Temperature Sensor	15	1.5	11.0	SS
Oil Pressure Switch Terminal Bolt	1.5	0.15	13 in-lb	
Oil Pressure Switch	15	1.5	11.0	SS
Neutral Switch Screw	3.9	0.40	35 in-lb	
Starter Lockout Switch Screws	1.0	0.10	9 in-lb	
Side Stand Switch Screws	-	-	-	L

Special Tools and Sealant

Inside Circlip Pliers: 57001-143

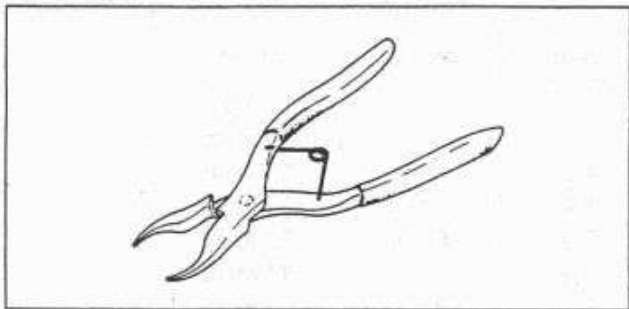

Outside Circlip Pliers: 57001-144

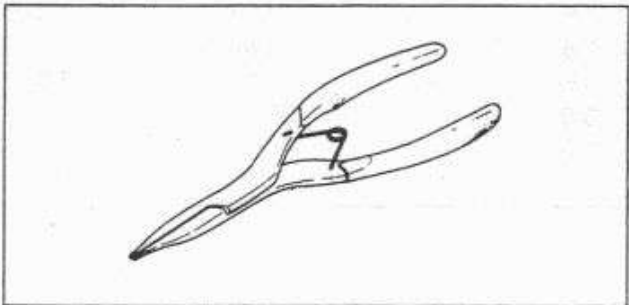

Oil Pressure Gauge, 10 kg/cm<sup>2</sup>: 57001-164

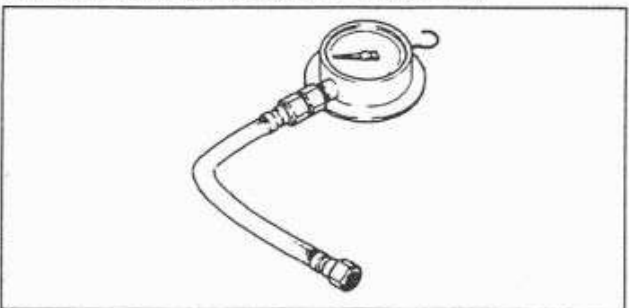

Compression Gauge: 57001-221

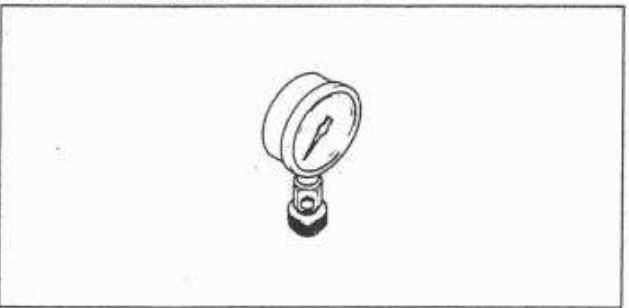

Valve Spring Compressor Assembly: 57001-241

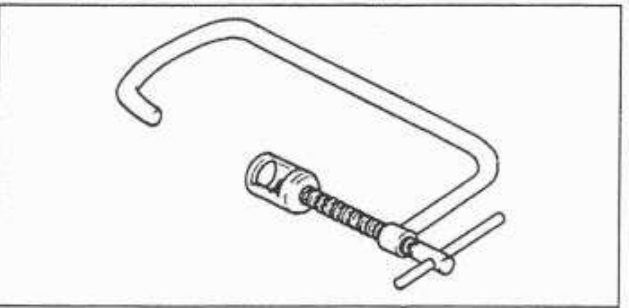

Piston Pin Puller Assembly: 57001-910

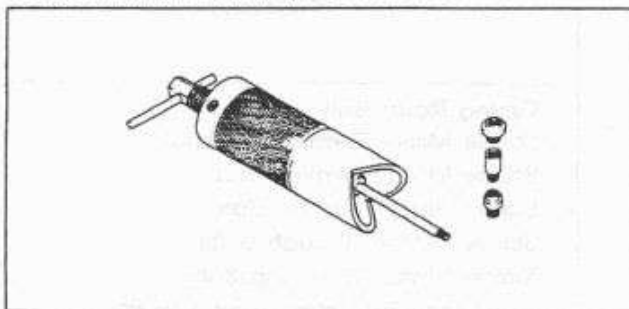

Fuel Level Gauge: 57001-1017

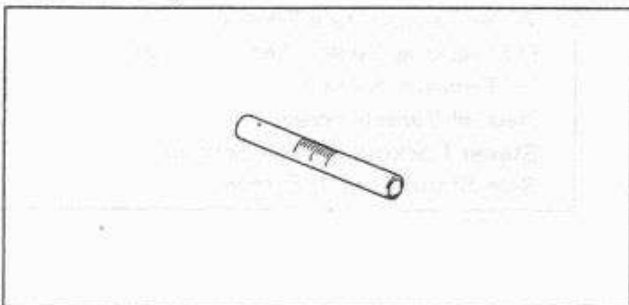

Oil Pressure Gauge Adapter, PT 1/8: 57001-1033

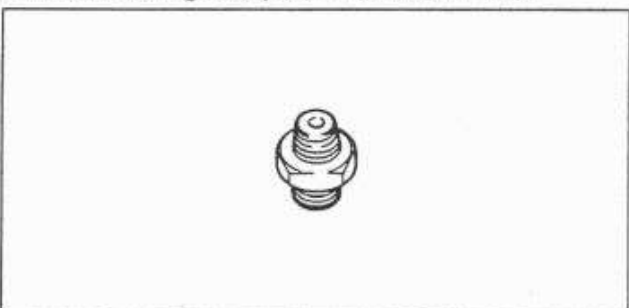

Oil Seal & Bearing Remover: 57001-1058

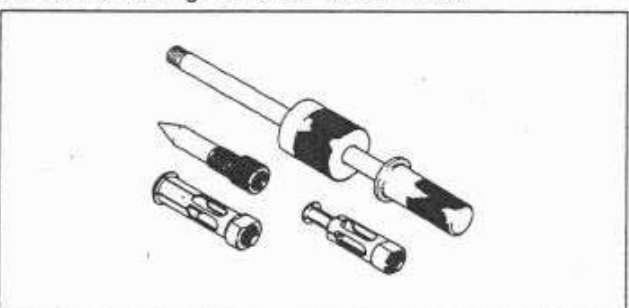

Head Pipe Outer Race Press Shaft: 57001-1075

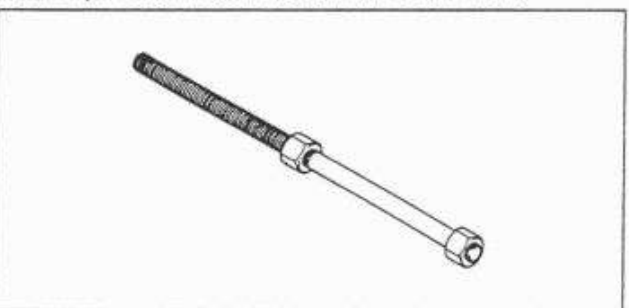

Head Pipe Outer Race Driver: 57001-1077

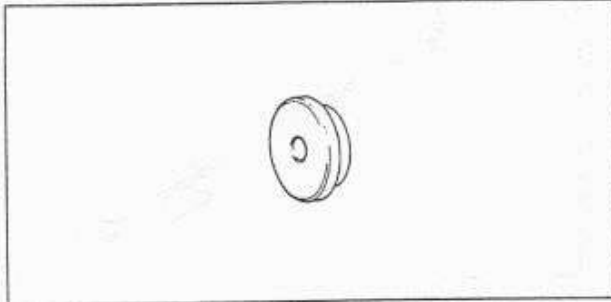

Valve Seat Cutter Holder Bar: 57001-1128

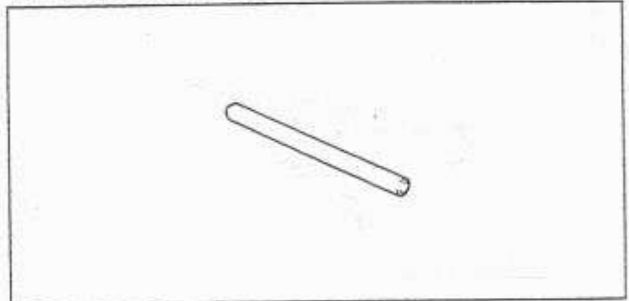

Steering Stem Nut Wrench: 57001-1100

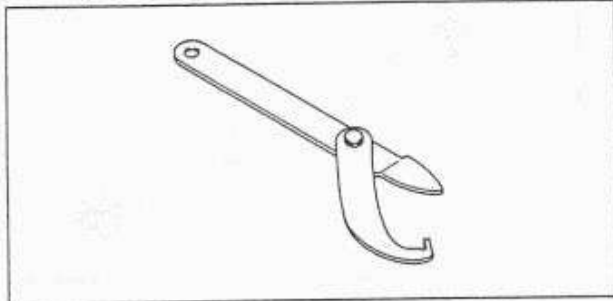

Bearing Driver Set: 57001-1129



Valve Seat Cutter, 45° -  $\phi 27.5$ : 57001-1114

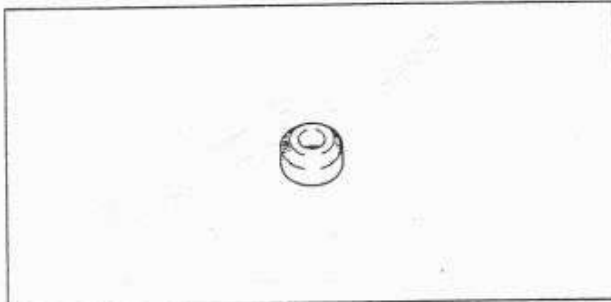

Valve Spring Compressor Adapter,  $\phi 22$ : 57001-1202

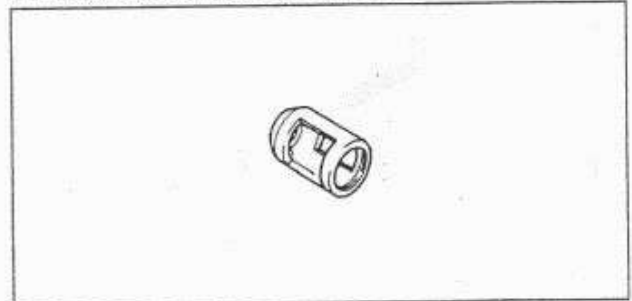

Valve Seat Cutter, 32° -  $\phi 28$ : 57001-1119

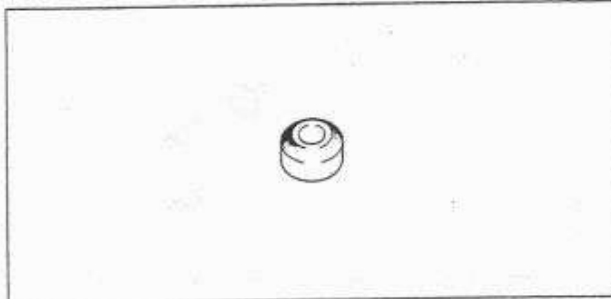

Fork Outer Tube Weight: 57001-1218

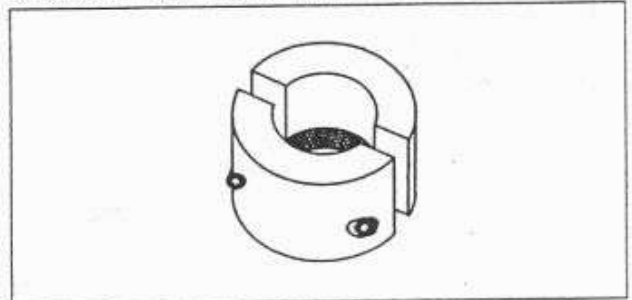

Valve Seat Cutter, 60° -  $\phi 30$ : 57001-1123

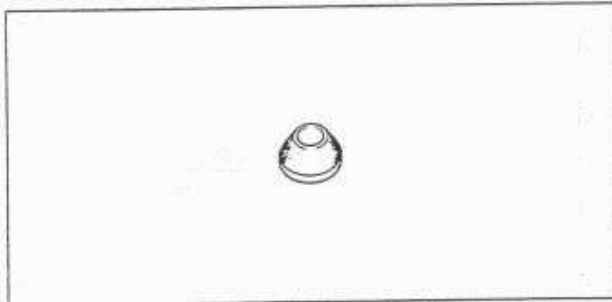

Jack: 57001-1238

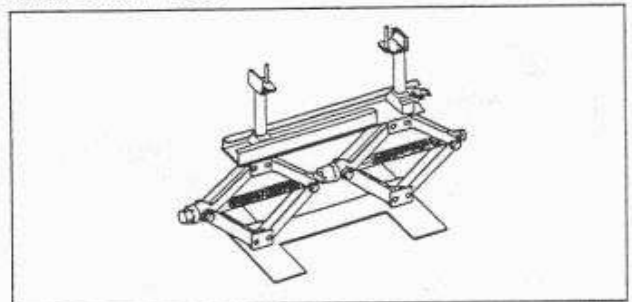

Clutch Holder: 57001-1243

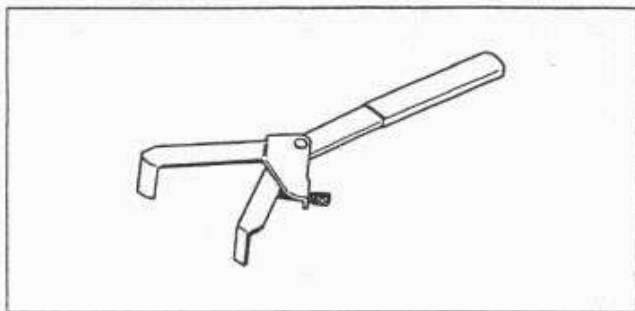

Pilot Screw Adjuster, C: 57001-1292

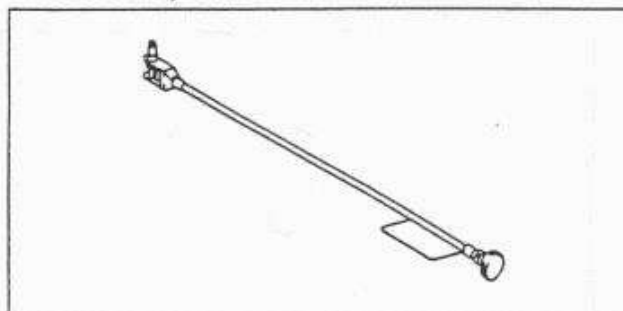

Oil Filter Wrench: 57001-1249

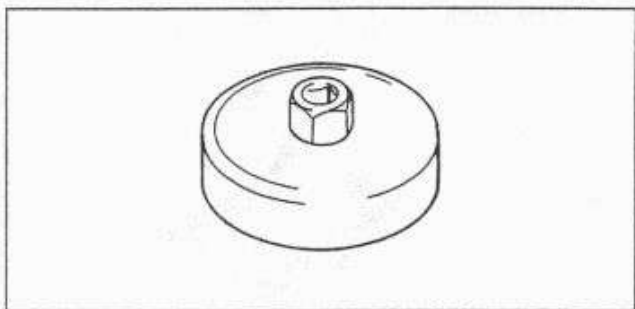

Fork Cylinder Holder: 57001-1297

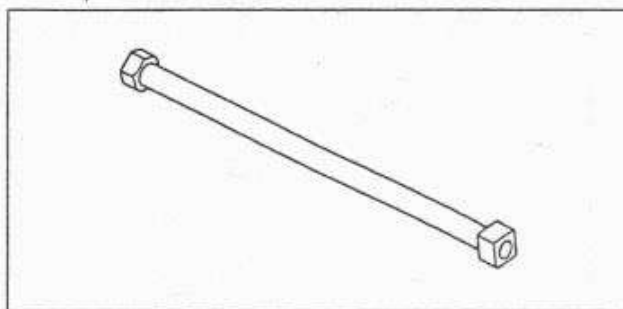

Bearing Remover Shaft: 57001-1265

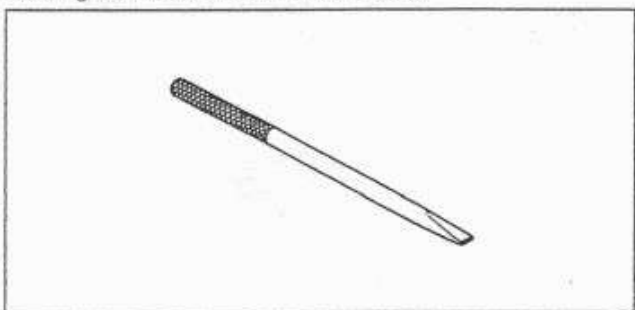

Fork Piston Rod Puller, M10 x 1.0: 57001-1298

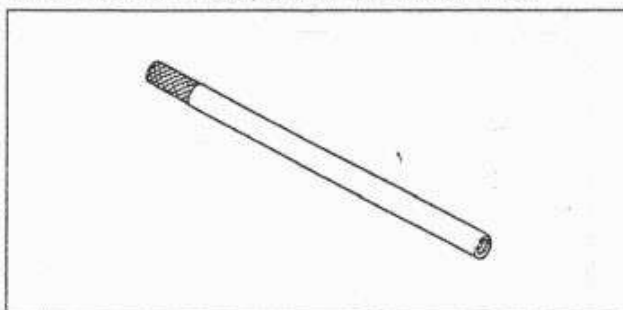

Carburetor Drain Plug Wrench, Hex 3: 57001-1269

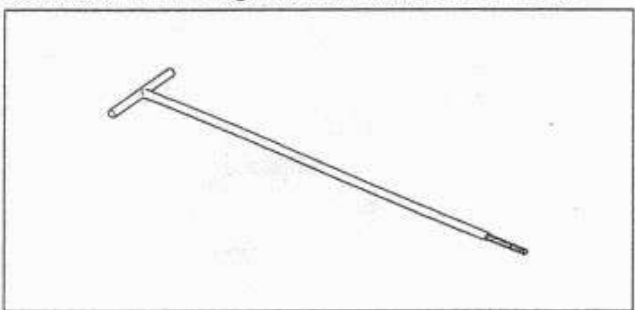

Compression Gauge Adapter, M10 X 1.0: 57001-1317

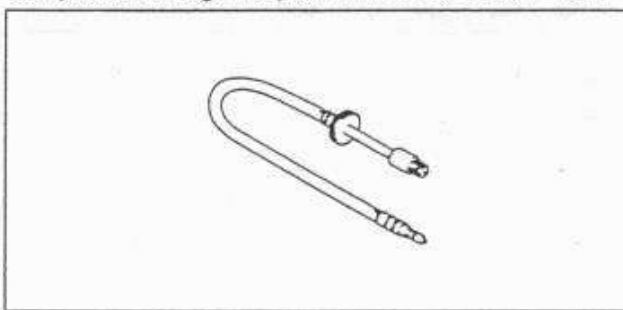

Fork Oil Level Gauge: 57001-1290

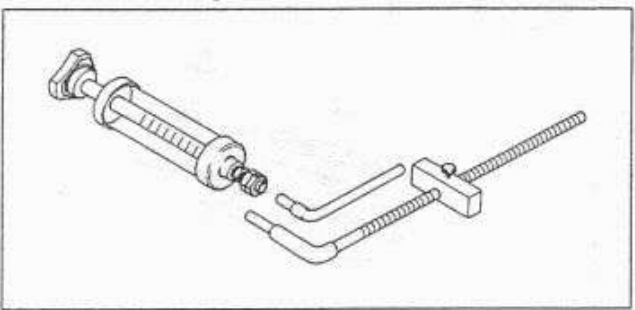

Valve Seat Cutter Holder,  $\phi 4.5$ : 57001-1330

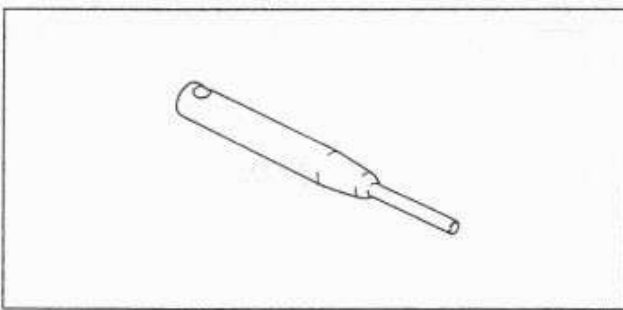



Valve Guide Arbor,  $\phi 4.5$ : 57001-1331

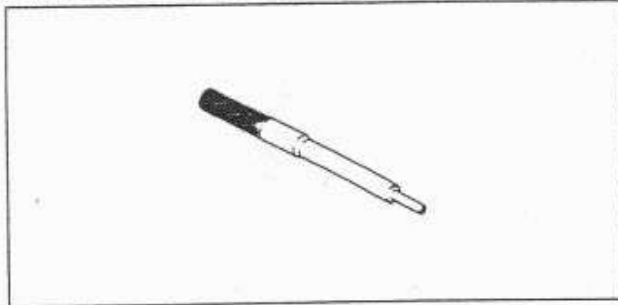

Steering Stem Bearing Driver Adapter: 57001-1345

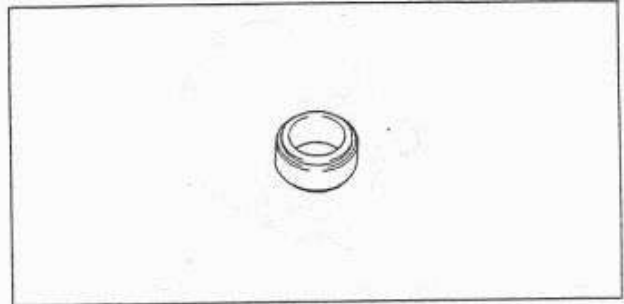

Valve Guide Reamer,  $\phi 4.5$ : 57001-1333

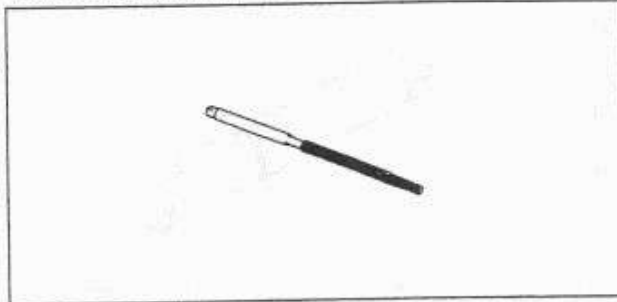

Bearing Remover Head,  $\phi 25 \times \phi 28$ : 57001-1346

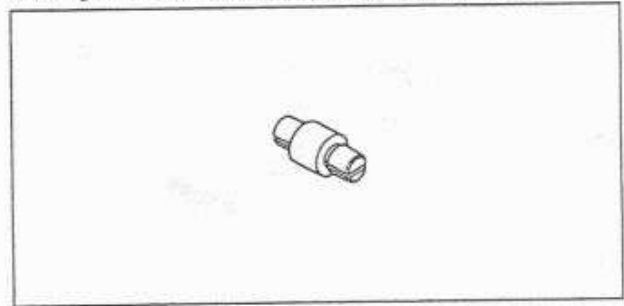

Fork Spring Compressor: 57001-1338

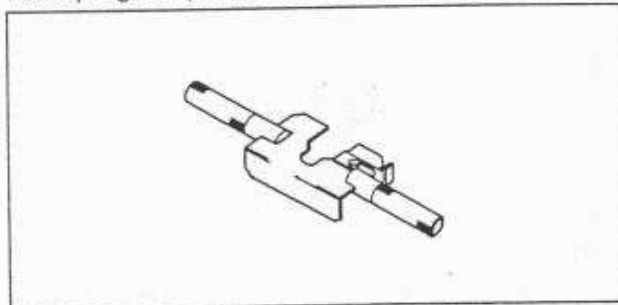

Socket Wrench: 57001-1347

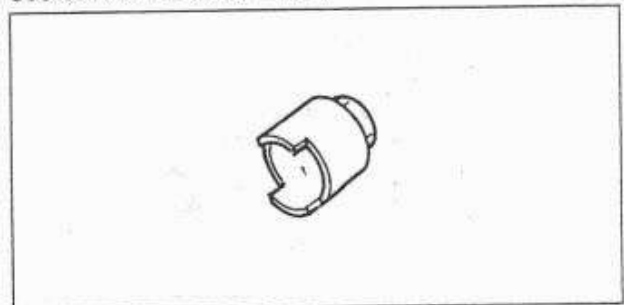

Fork Oil Seal Driver,  $\phi 43$ : 57001-1340

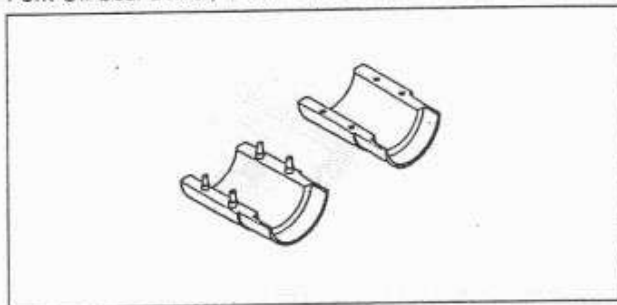

Crankcase Splitting Tool Assembly: 57001-1362

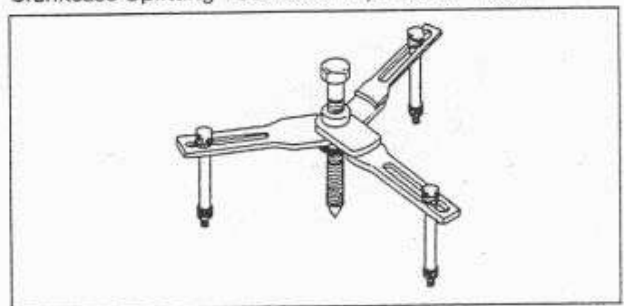

Steering Stem Bearing Driver: 57001-1344

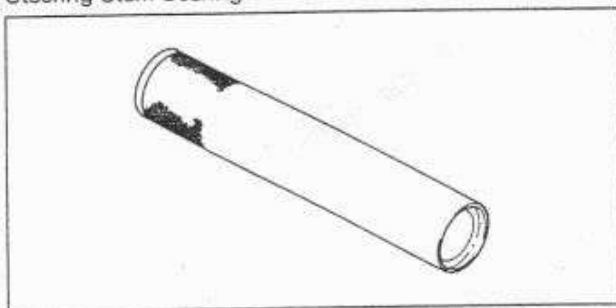

Vacuum Gauge: 57001-1369

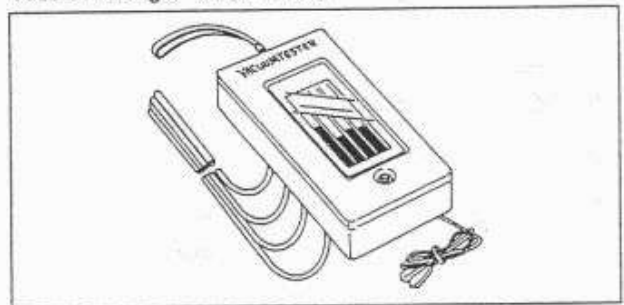

Socket Wrench: 57001-1370

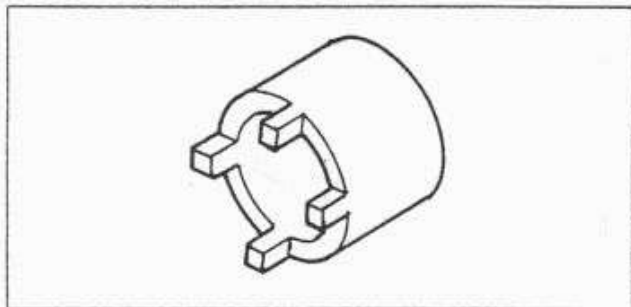

Vacuum Gauge Bolt Washer: 92022-304

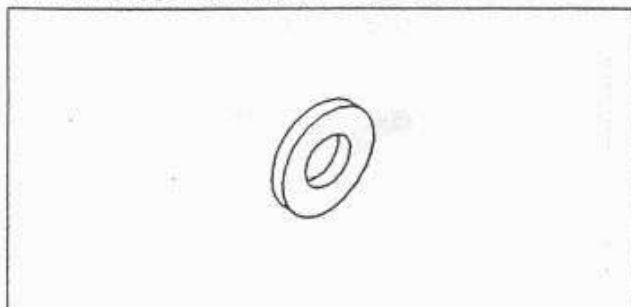

Pilot Screw Adjuster Adapter,  $\phi 5$ : 57001-1372

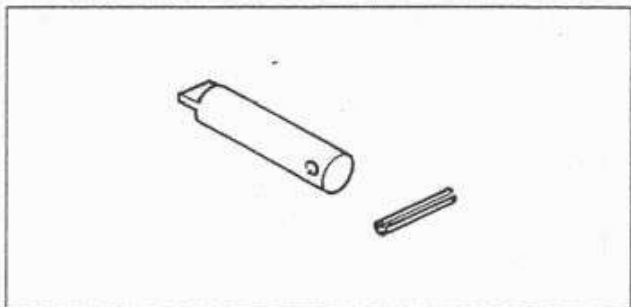

Spark Plug Wrench, 16mm: 92110-1154

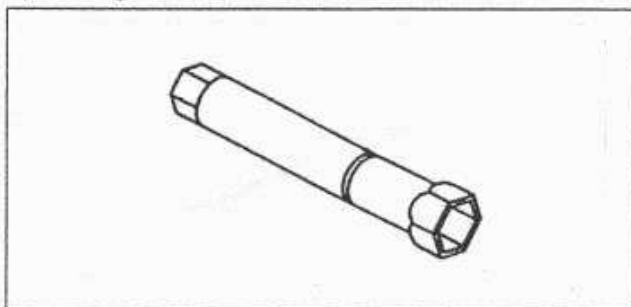

Pilot Screw Adjuster Driver: 57001-1373

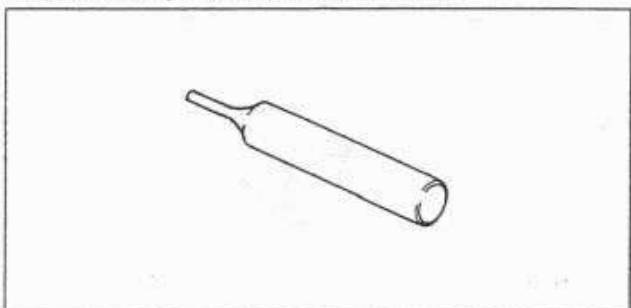

Vacuum Gauge Bolt: 92150-1161

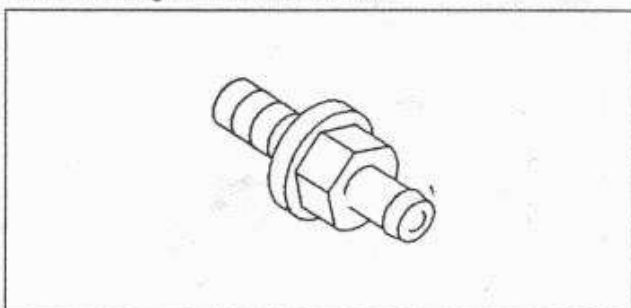

Hand Tester: 57001-1394

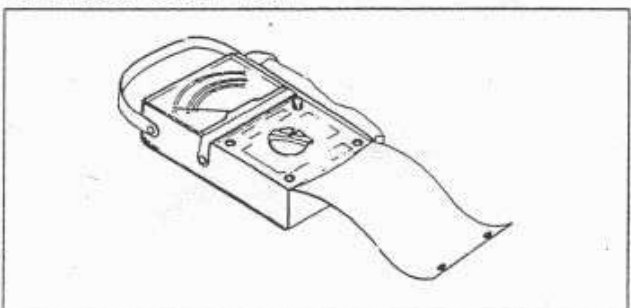

Pressure Cable Luber: K56019-021

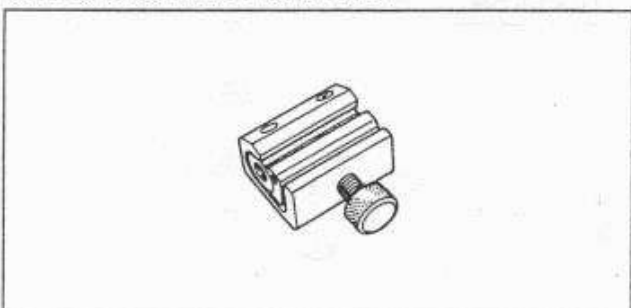

Fork Cylinder Holder: 57001-1396

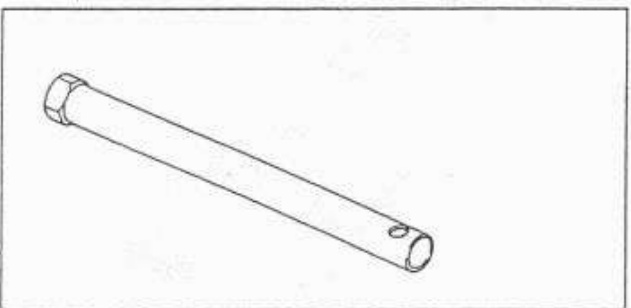

Kawasaki Bond (Silicone Sealant): 56019-120

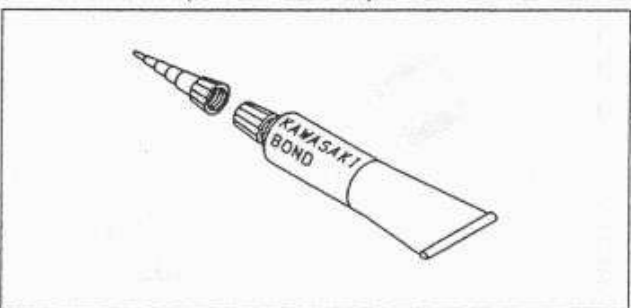



Technical drawing with text, possibly a legend or description of the components shown in the diagrams above. The text is oriented vertically and includes various alphanumeric labels.

Technical drawing with text, possibly a legend or description of the components shown in the diagrams above. The text is oriented vertically and includes various alphanumeric labels.

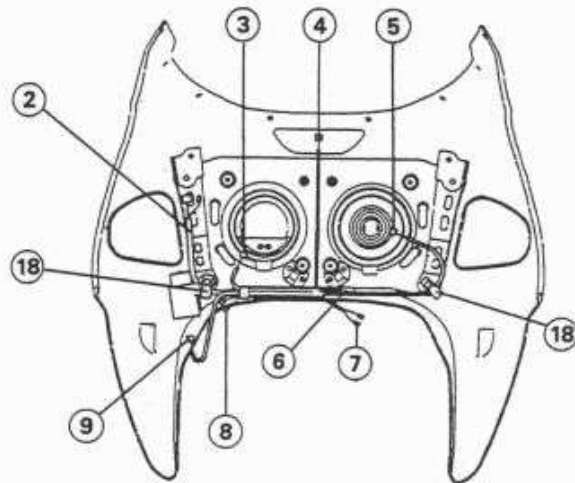
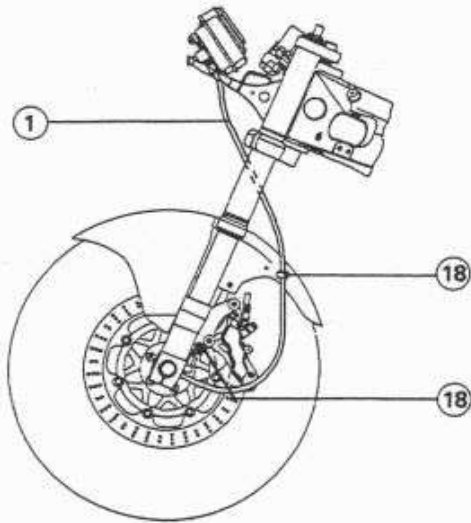

ZX750N:

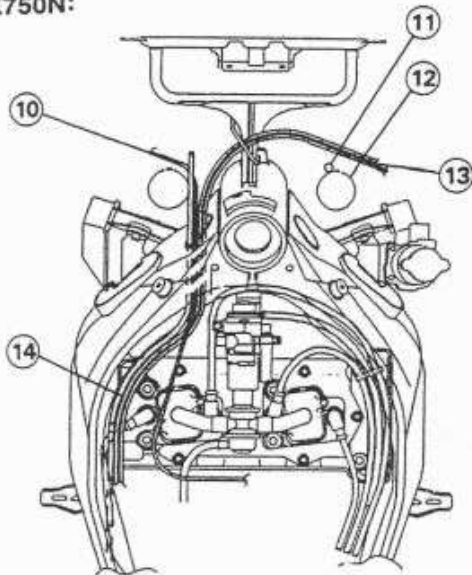

ZX750P:

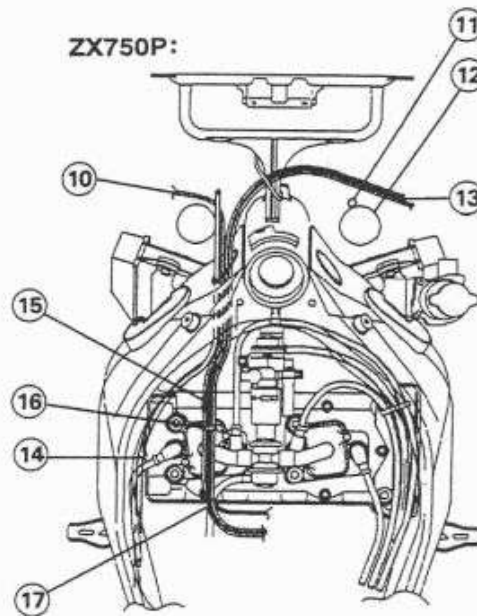

(AS): Australia

(UK): U.K.

- 1. Speedometer Cable
- 2. Main Harness
- 3. Left Headlight
- 4. City Light (Europe Models)
- 5. Right Headlight
- 6. Diode (Europe Models except UK Model)
- 7. Right Turn Signal Light Leads
- 8. Left Turn Signal Light Leads
- 9. High Beam Relay (AS and UK Models)
- 10. Choke Cable (Run the choke cable outside the clutch hose).

- 11. Brake Hose
- 12. Front Fork
- 13. Throttle Cables
- 14. Clutch Hose
- 15. Choke Cable Adjuster
- 16. Separate the clamp by 15 ~ 20mm from the adjuster backward.
- 17. Run the throttle cables on the air vent pipe. Run the choke cable under the air vent pipe.
- 18. Clamp

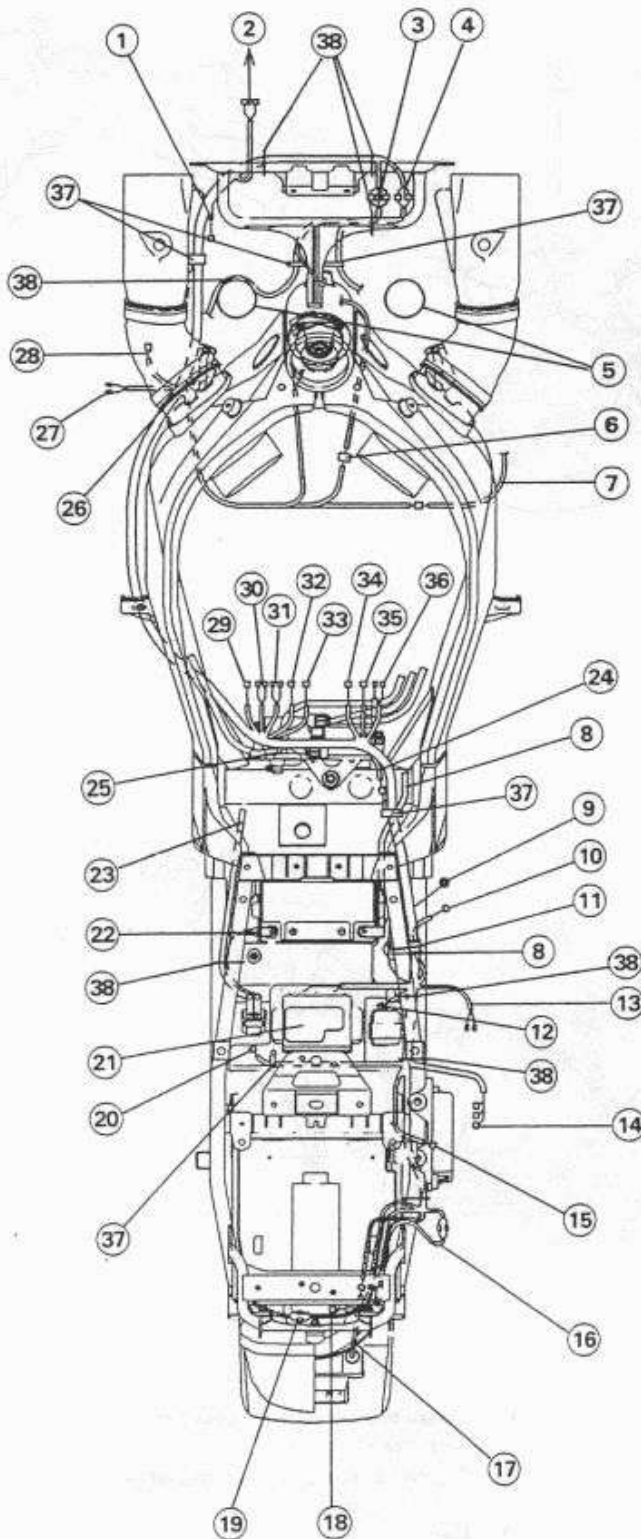

1. Front Sub Harness
2. Meter Unit
3. Left Handlebar Switch
4. Right Handlebar Switch
5. Front Fork
6. Ignition Switch Lead
7. Water Temperature Sensor Lead
8. Battery Ground (-) Lead
9. Chassis Ground Lead
10. Rear Brake Light Switch Lead
11. Band (Rubber Protector on the Harness)
12. Fuel Pump Relay Lead
13. Accessory Leads
14. IC Igniter Connectors
15. Turn Signal Relay
16. Rear Right Turn Signal Light Lead
17. License Plate Light Lead
18. Tail/Brake Lights Lead
19. Rear Left Turn Signal Light Lead
20. Starter Relay Lead
21. Junction Box
22. Battery Positive (+) Lead
23. Starter Motor Lead
24. Fuel Pump Lead
25. Insert the harness clamp into the hole in the ignition coil bracket.
26. Insert the harness clamp into the hole in the radiator bracket.
27. Radiator Fan Switch Leads
28. Fan Motor Lead
29. Neutral Switch
30. Side Stand Switch
31. #2, #3 Ignition Coil
32. Alternator
33. Solenoid Valve (ZX750N)
34. Throttle Switch (ZX750N)
35. Pickup Coil
36. #1, #4 Ignition Coil
37. Clamp
38. Band

Left Side View:

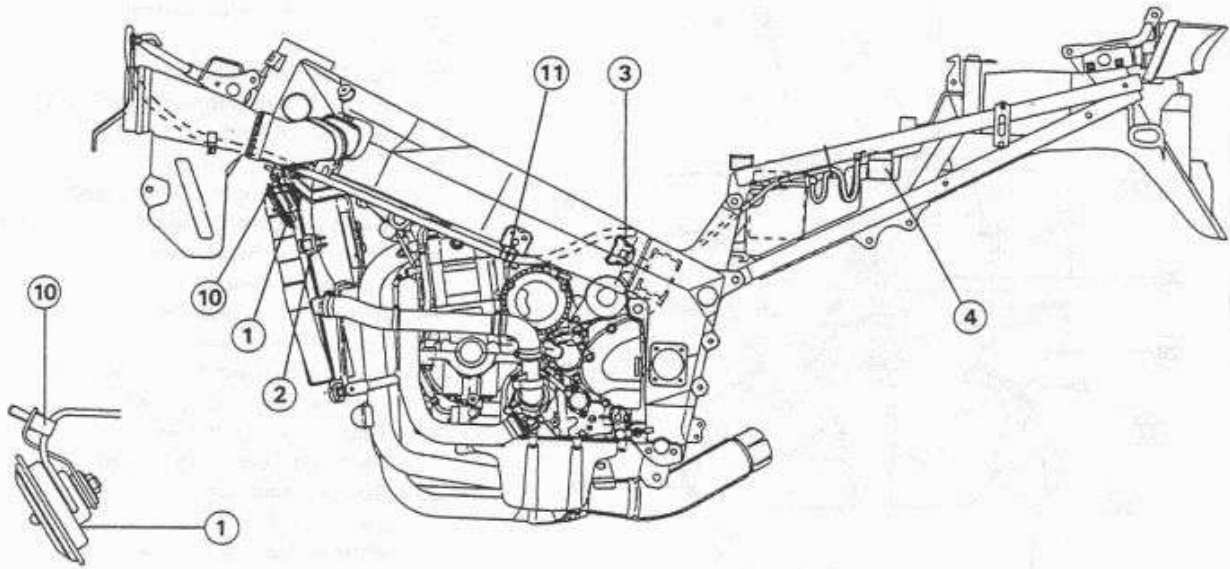

Right Side View

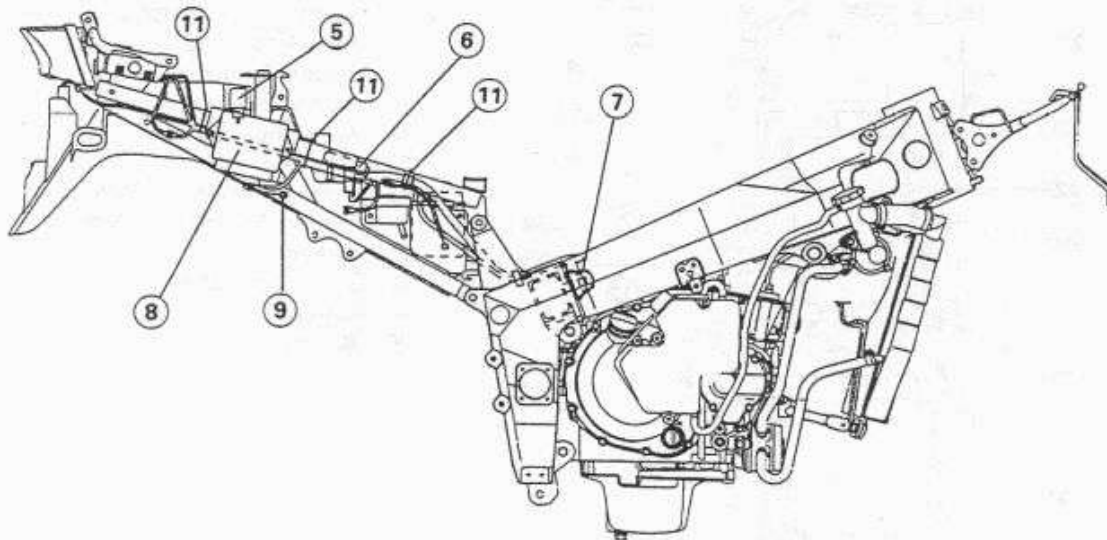

- |                         |                         |  |
|-------------------------|-------------------------|--|
| 1. Horn                 | 5. Turn Signal Relay    | 9. Install the chassis ground terminal with the rear fender. |
| 2. Radiator Fan Switch  | 6. Fuel Pump Relay      | 10. Tighten the clamp with the left side mounting bolt.      |
| 3. #2, #3 Ignition Coil | 7. #1, #4 Ignition Coil | 11. Band   |
| 4. Starter Relay        | 8. IC Igniter           |  |

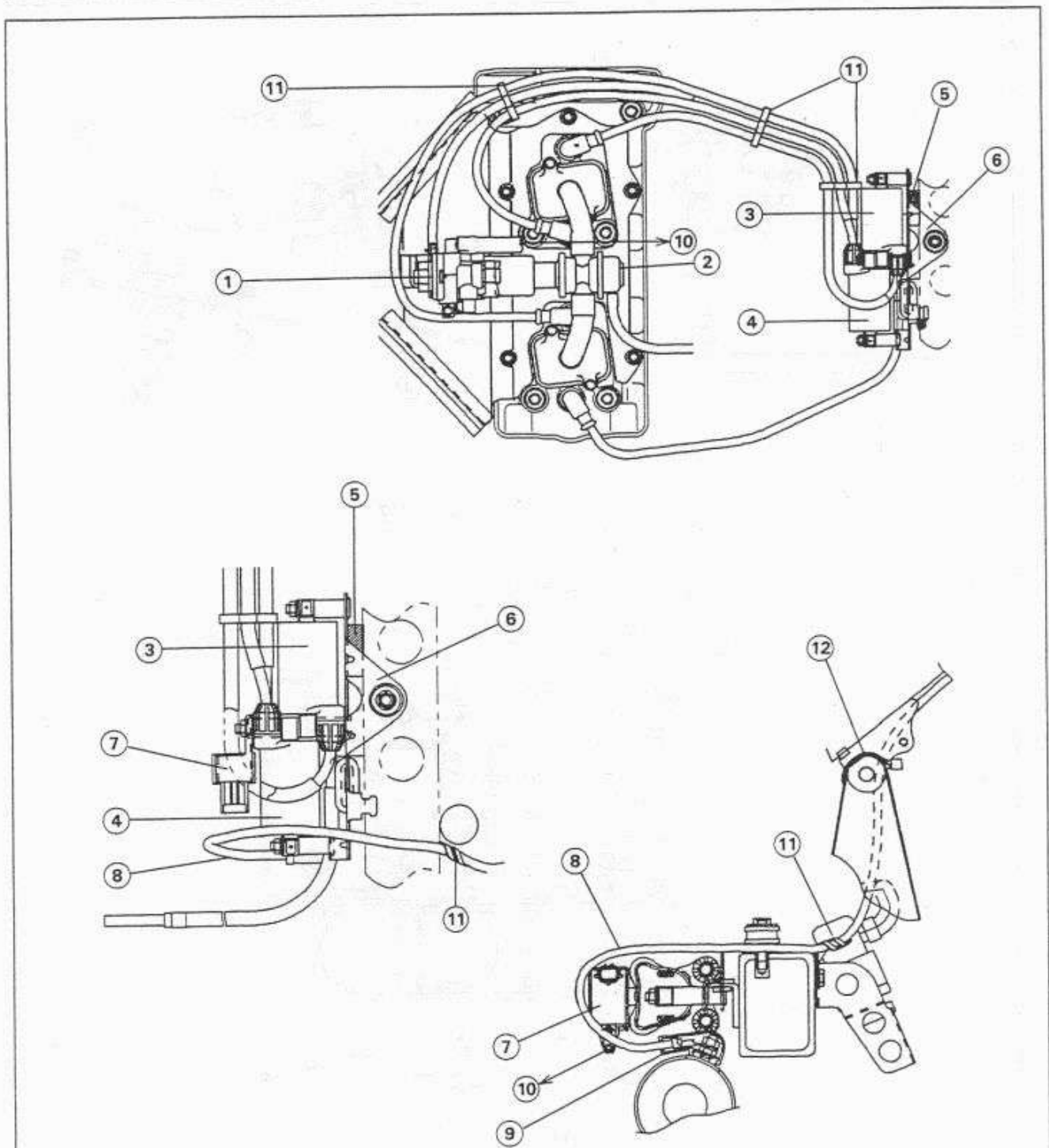

- |                         |   |           |
|-------------------------|---|-----------|
| 1. Vacuum Valve         | 6. Ignition Coil Bracket                      | 11. Clamp |
| 2. Vacuum Switch Valve  | 7. Solenoid Valve                             | 12. Band  |
| 3. #1, #4 Ignition Coil | 8. Starter Motor Lead                         |           |
| 4. #2, #3 Ignition Coil | 9. Bend the starter motor lead terminal down. |           |
| 5. Damper               | 10. Carburetors                               |           |

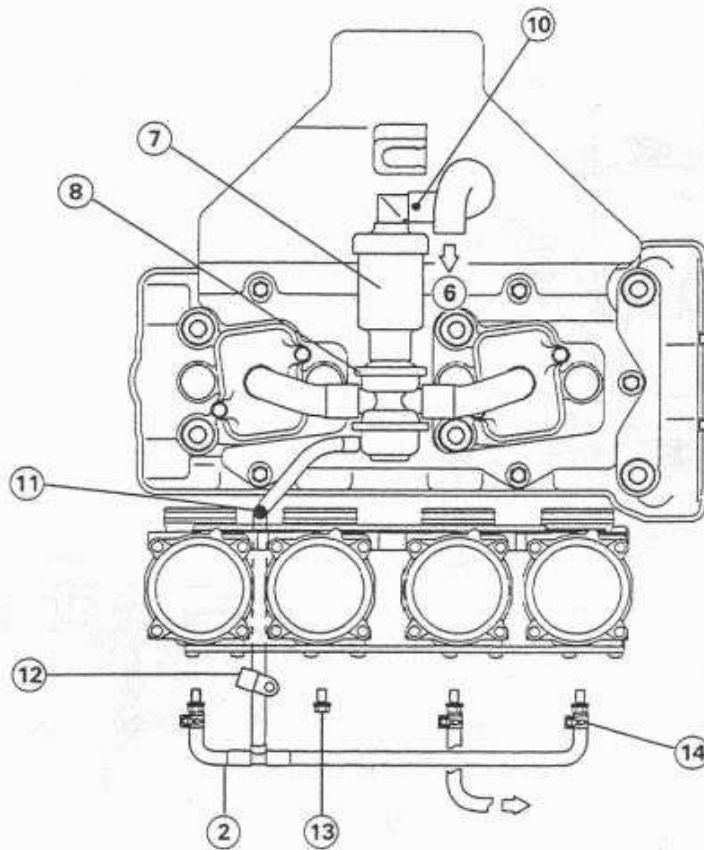
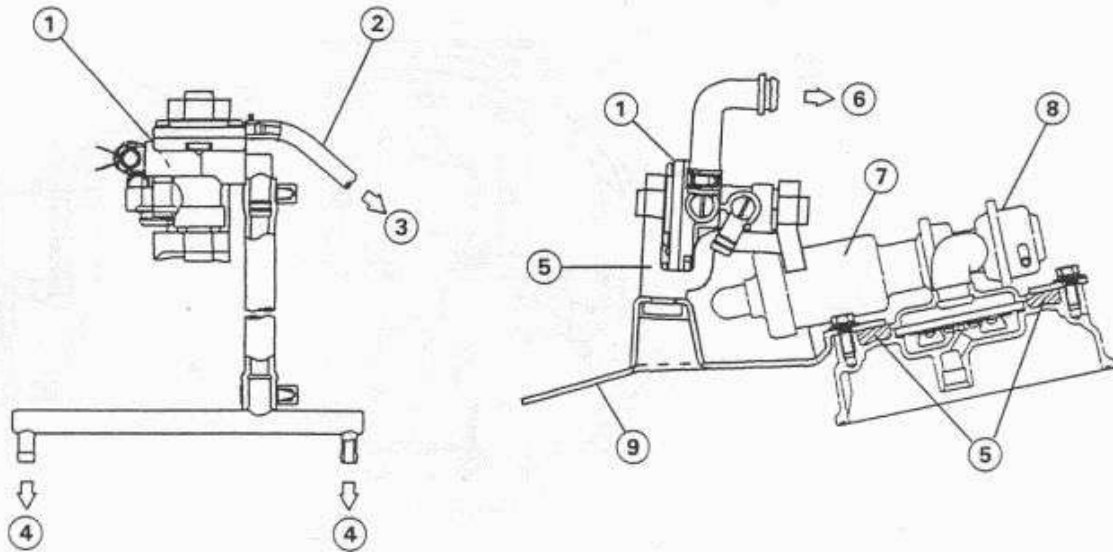

- |                        |   |   |
|------------------------|---|---|
| 1. Vacuum Valve        | 7. Intake Silencer  | 12. Run the vacuum hose inside the clamp on the #2 carburetor holder. |
| 2. Vacuum Hose         | 8. Vacuum Switch Valve  | 13. Inlet Pipe Plug   |
| 3. #3 Vacuum Fitting   | 9. Baffle Plate   | 14. Clamp   |
| 4. Carburetor Air Vent | 10. The white mark points upward.                                 |   |
| 5. Damper              | 11. Run the vacuum hose between the #1 and #2 carburetor holders. |   |
| 6. Air Cleaner Housing |   |   |



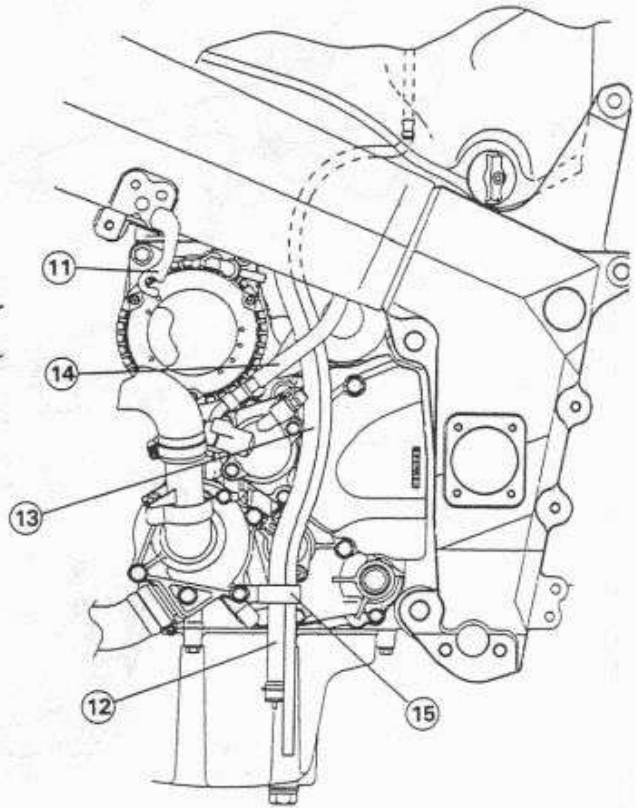
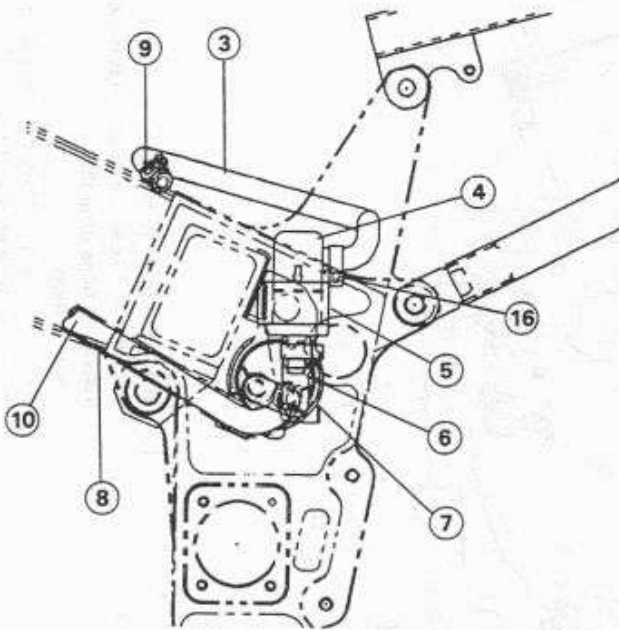
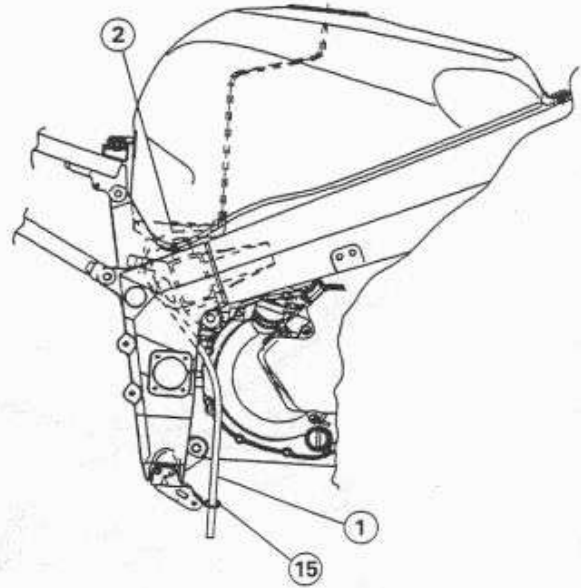
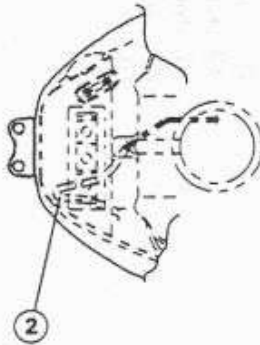

1. Fuel Tank Drain Hose
2. Run the drain hose inside the bracket.
3. Fuel Hose (Fuel Tank → Fuel Filter)
4. Fuel Filter
5. Damper
6. Fuel Hose (Fuel Filter → Fuel Pump)
7. Fuel Pump and Holder
8. Spring (for guard of the fuel hose)
9. The clamp knob points upward.

10. Fuel Hose (Fuel Pump → Carburetors / Run the left side hose of the carburetor front side the breather hose.)
11. Idle Adjusting Screw Bracket  
(Run the idle adjusting cable under the main harness)
12. Air Cleaner Drain Hose
13. Run the hose inside the clutch hose and hold it by the clamp.
14. Clutch Hose
15. Clamp
16. The clamp knob points downward.

AR: Austria  
 FG: Germany  
 FR: France  
 IT: Italy  
 KR: Korea  
 NL: Netherland  
 ST: Switzerland  
 UK: U.K.

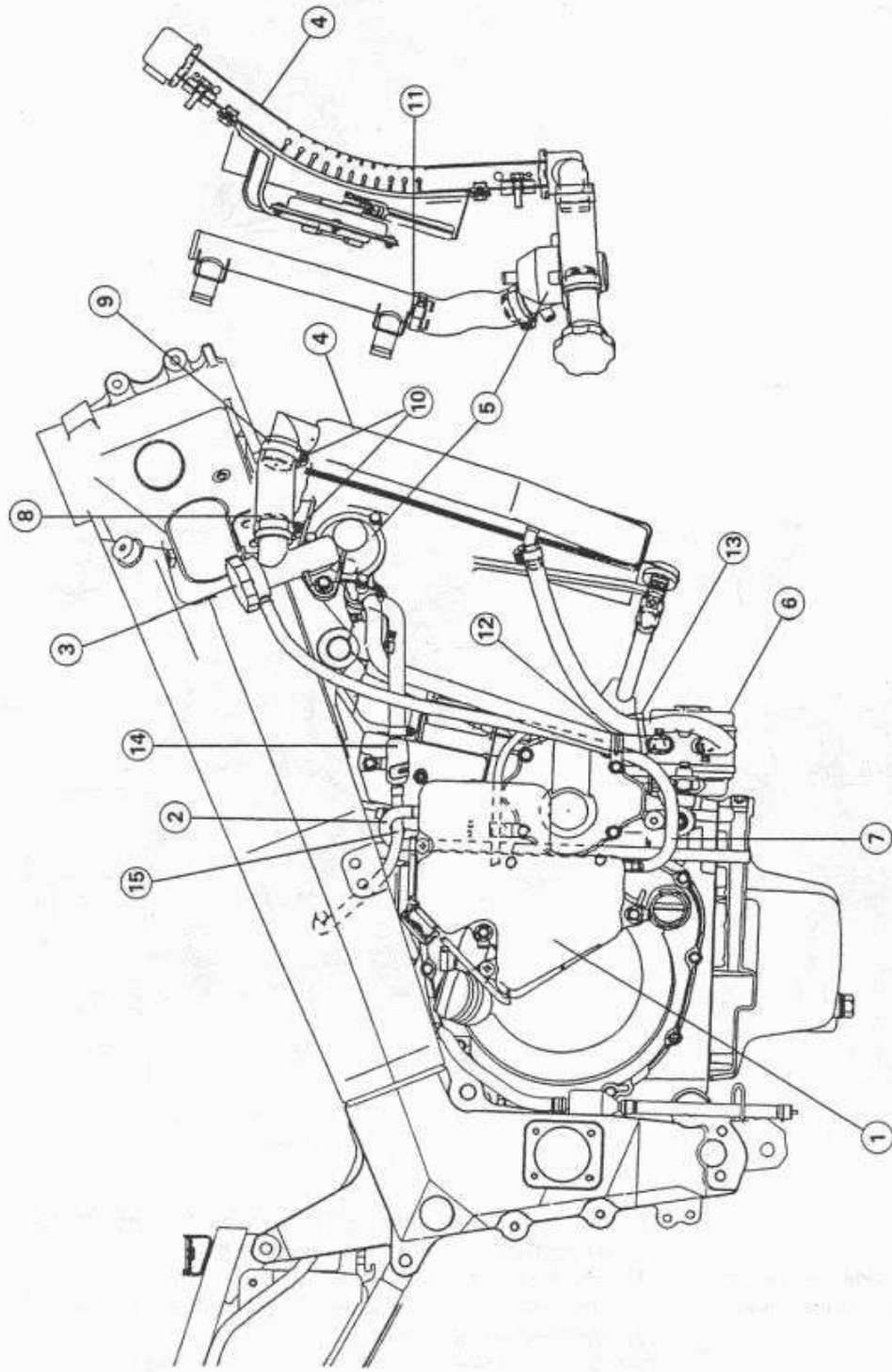

- |  |   |   |
|--|---|---|
| <ul style="list-style-type: none"> <li>1. Coolant Reserve Tank</li> <li>2. Reserve Tank Overflow Hose</li> <li>3. Radiator Cap</li> <li>4. Radiator</li> <li>5. Thermostat Housing</li> <li>6. Oil Cooler</li> <li>7. Reserve Tank Hose</li> </ul> | <ul style="list-style-type: none"> <li>8. Install the hose so that the yellow mark faces the thermostat housing.</li> <li>9. Install the hose until the elbow bottom.</li> <li>10. Install the clamp screws downward.</li> <li>11. Install the hose so that the white mark meets the water pipe bracket.</li> </ul> | <ul style="list-style-type: none"> <li>12. Clam</li> <li>13. Band</li> <li>(AR, FR, FR, IT, KR, NL, ST, UK Models)</li> <li>14. Coolant Filter</li> <li>15. Run the thin coolant filter hose between the bended overflow hose.</li> </ul> |
|--|---|---|

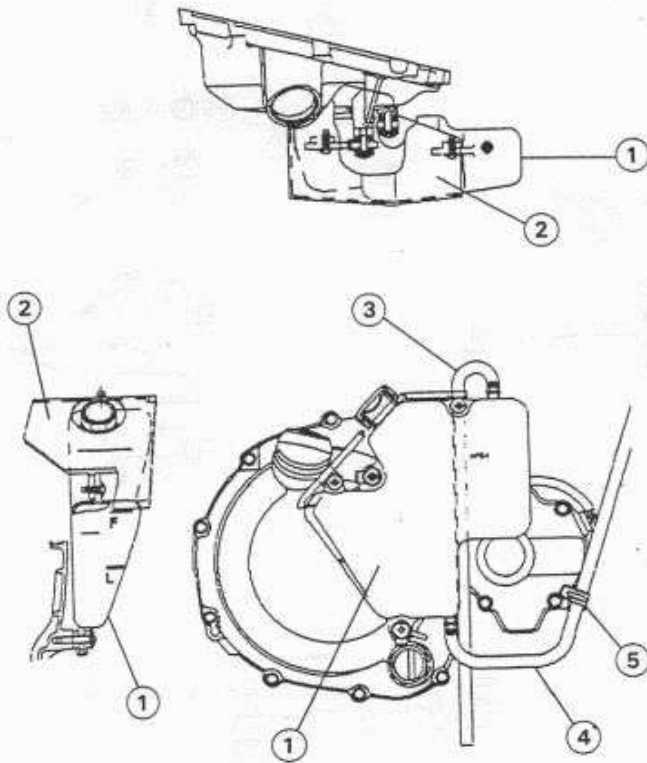

- 1. Coolant Reserve Tank
- 2. Reserve Tank Cover
- 3. Reserve Tank Overflow Hose
- 4. Reserve Tank Hose
- 5. Clamp

(AR, FG, FR, IT, KR, NL, ST, UK Models)

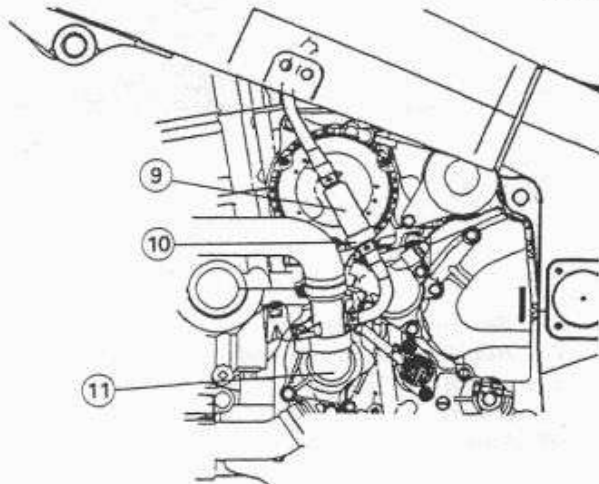
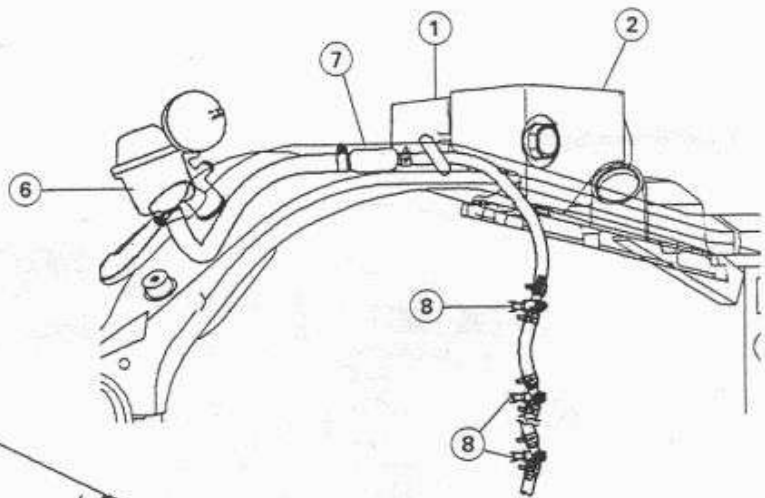

- 6. Thermostat Housing
- 7. Coolant Filter
- 8. To Carburetor
- 9. Coolant Valve
- 10. Install the valve so that the stepped side is downward.
- 11. Water Pump

Front Brake System

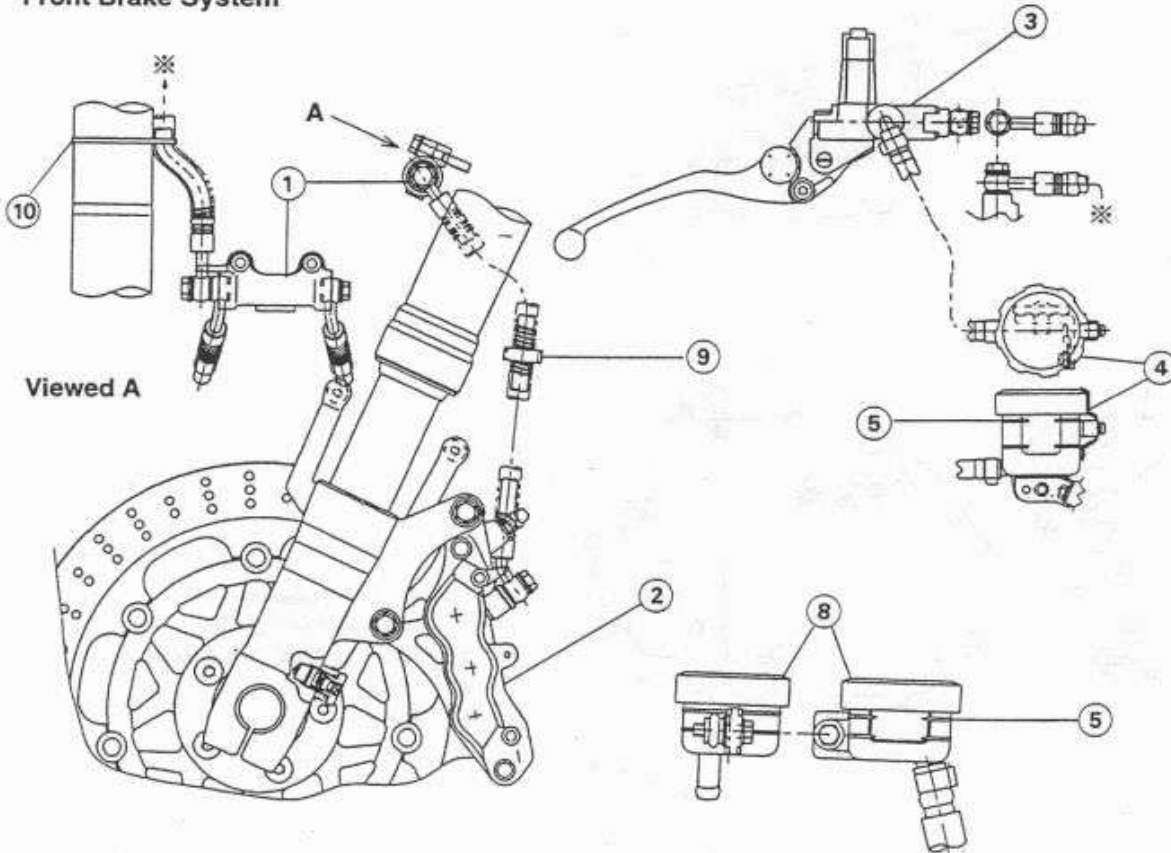

Rear Brake System

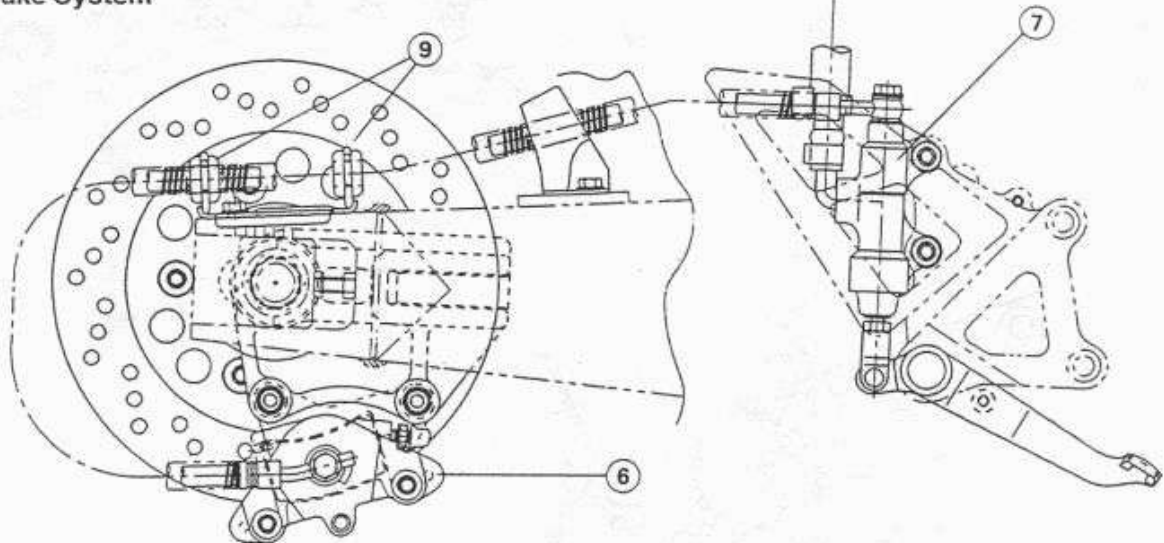

- 1. Brake Hose Joint
- 2. Front Brake Caliper
- 3. Front Brake Master Cylinder
- 4. Front Brake Reservoir
- 5. Upper Lever Line of Brake Fluid

- 6. Rear Brake Caliper
- 7. Rear Brake Master Cylinder
- 8. Rear Brake Reservoir
- 9. Clamp
- 10. Band

ZX750N:

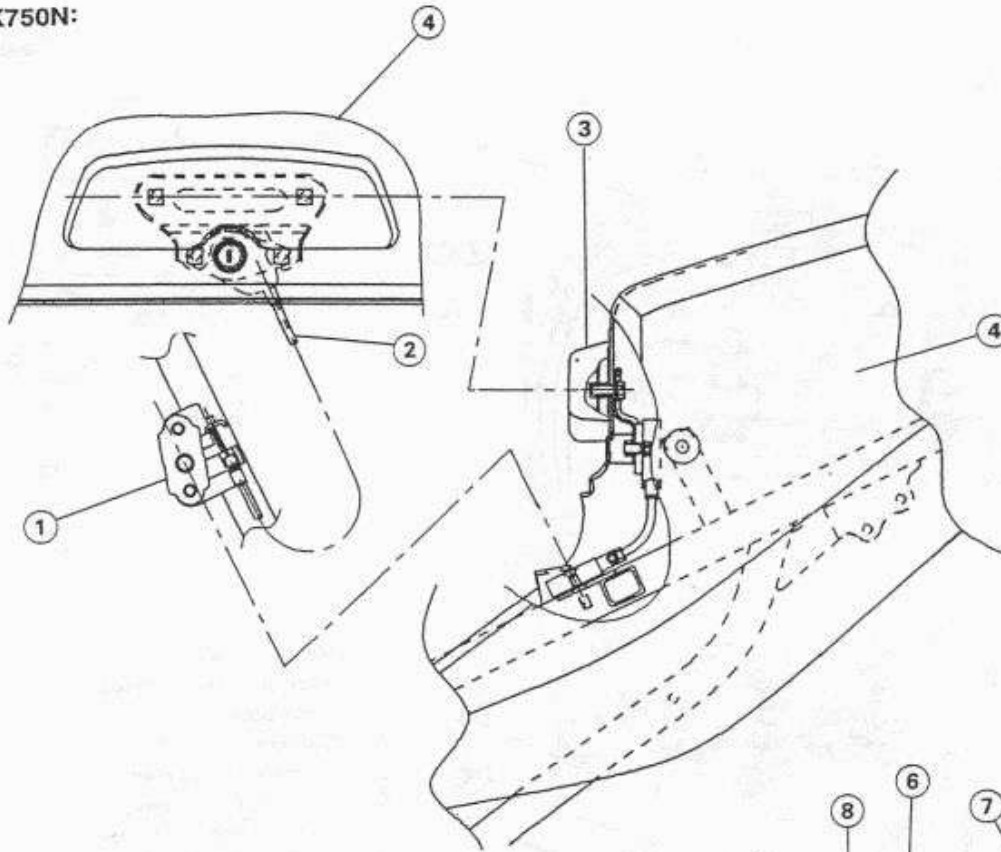

ZX750P:

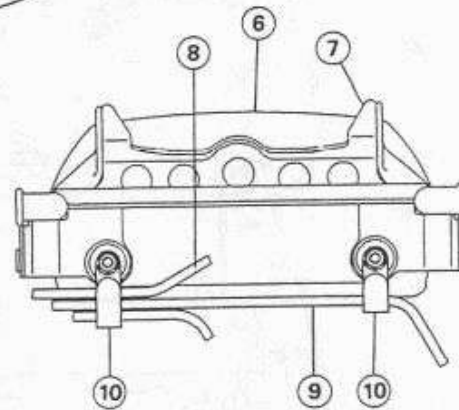
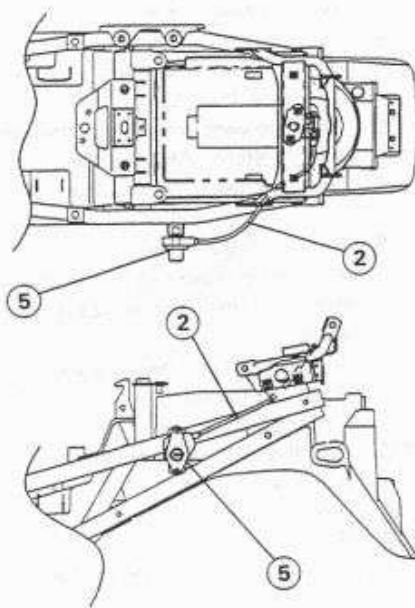

1. Seat Lock
2. Seat Lock Cable
3. Pad
4. Seat Cover
5. Rear Seat Lock
6. Tail/Brake Light
7. Tail/Brake Light Bracket
8. Tail/Brake Light Lead
9. Rear Left Turn Signal Light Lead
10. Clamp

Evaporative Emission Control System (California)

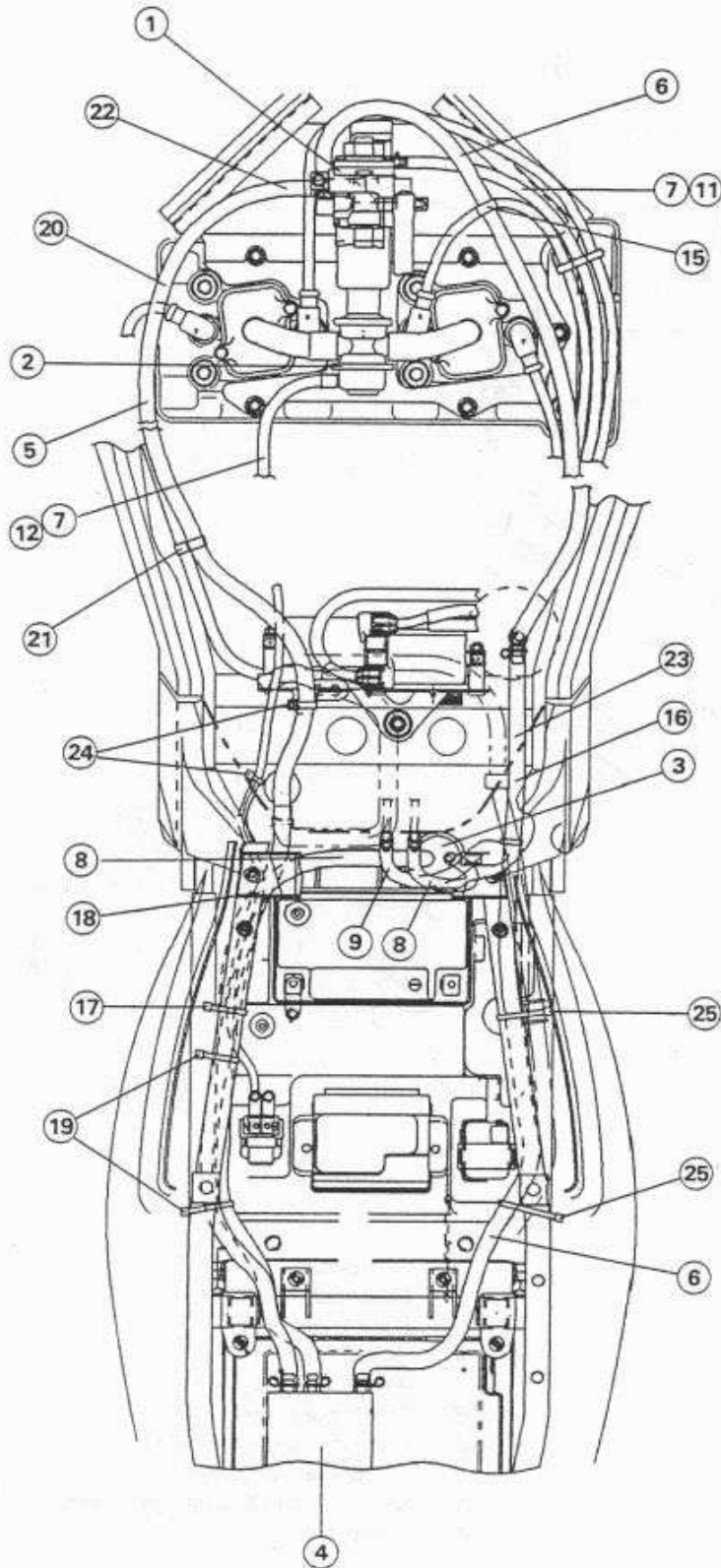

Rear View

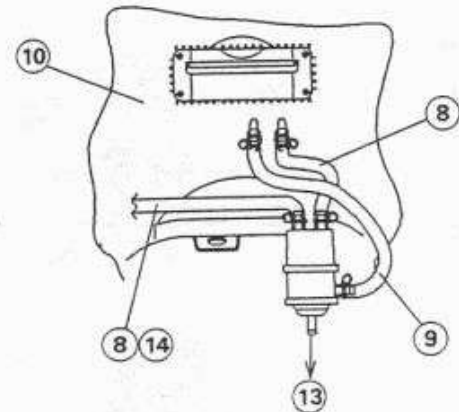

1. Vacuum Valve
  2. Vacuum Switch Valve
  3. Separator
  4. Canister
  5. Purge Hose (Green)
  6. Vent Hose (Yellow)
  7. Vacuum Hose (White)
  8. Breather Hose (Blue)
  9. Return Hose (Red)
  10. Fuel Tank
  11. To #3 Vacuum fitting
  12. To #1, 4 Vacuum Fittings
  13. To #2 Vacuum Fitting
  14. To Canister
  15. Clamp (Vent Hose and #3 Spark Plug Lead)
  16. Run the vent hose under the harness.
  17. Band (Starter Motor Lead)
  18. Run the purge hose at the corner of the battery.
  19. Band (Purge Hose)
  20. Run the purge hose under the throttle cables and #2 spark plug lead.
  21. Clamp (Purge Hose and #1 Spark Plug Lead)
  22. To Intake Silencer
  23. Run the vent hose outside the harness.
  24. Clamp
  25. Band
- The hoses are not too tight by bands.

## Evaporative Emission Control System (California)

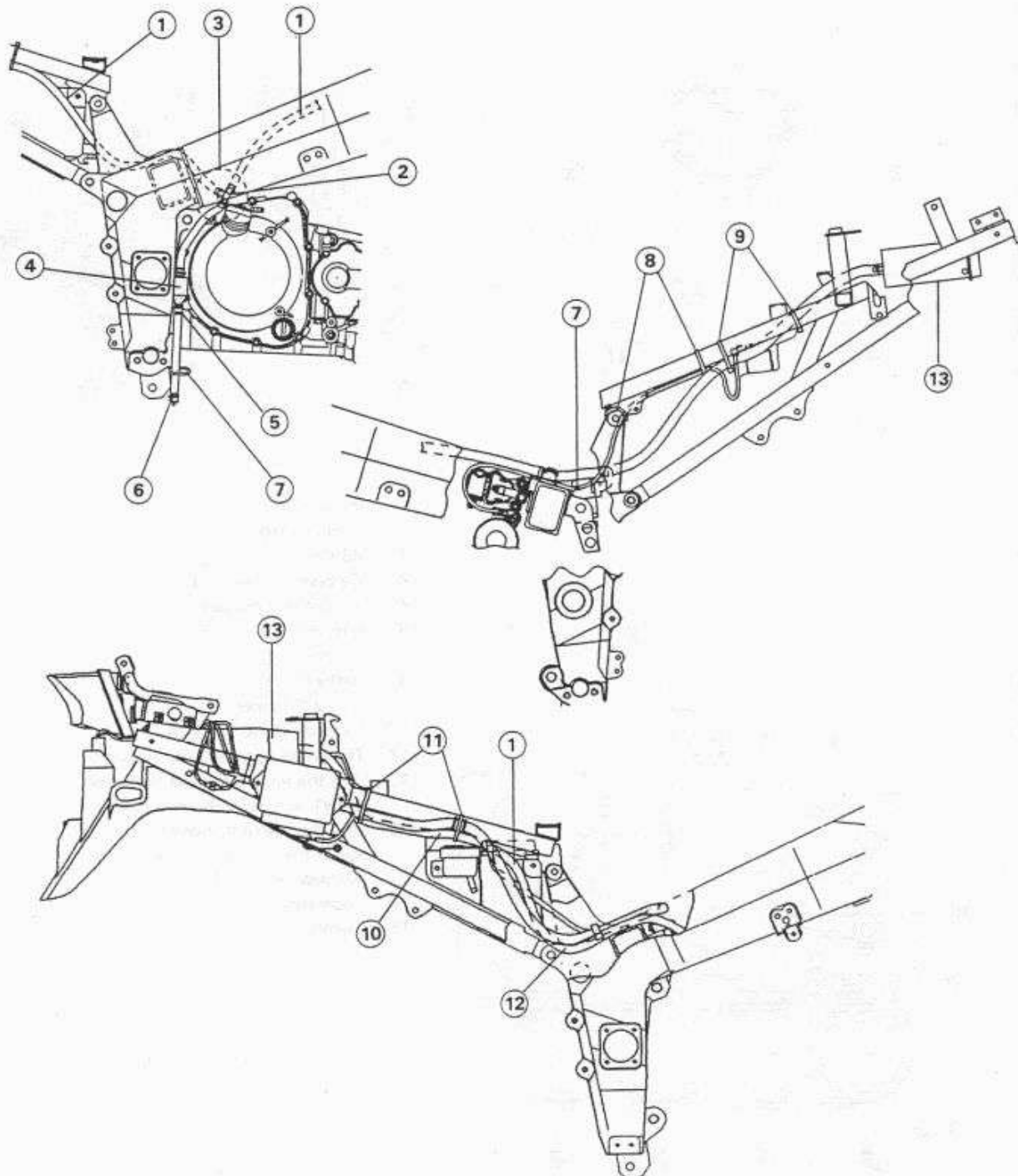

1. Vent Hose (Yellow)
2. T-type Fitting
3. Install the fitting at bottom of the vent hoses (Yellow).
4. Catch Tank
5. Install the catch tank inside the frame.
6. Drain Plug
7. Clamp
8. Bands (Starter Motor Cable)
9. Bands (Purge Hose, Green)
10. Run the vent hose from under the harness to inside.
11. Bands (Vent Hose and Harness)
12. Run th vent hose under the harness.
13. Canister

Evaporative Emission Control System (California)

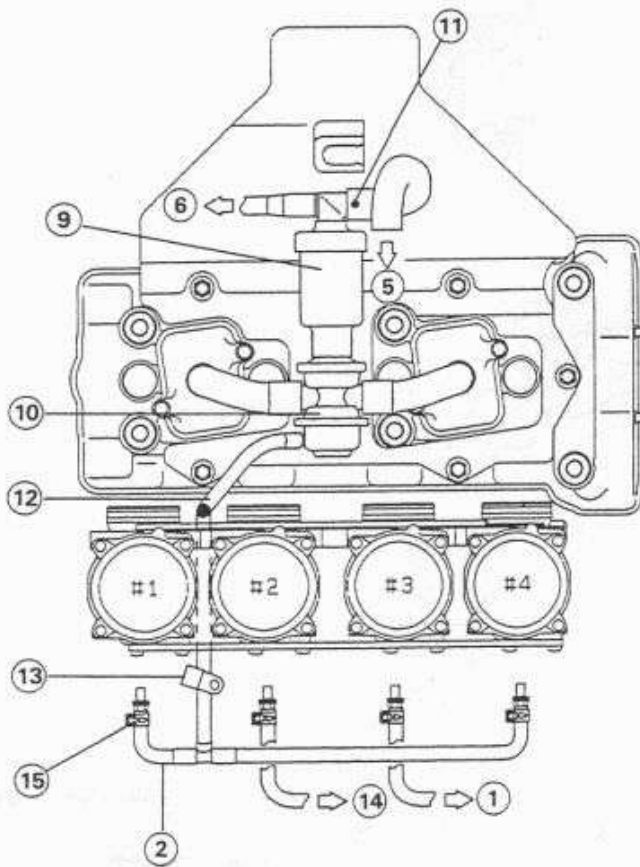
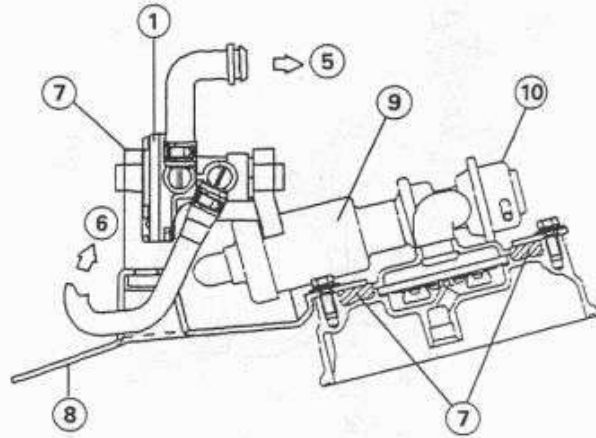
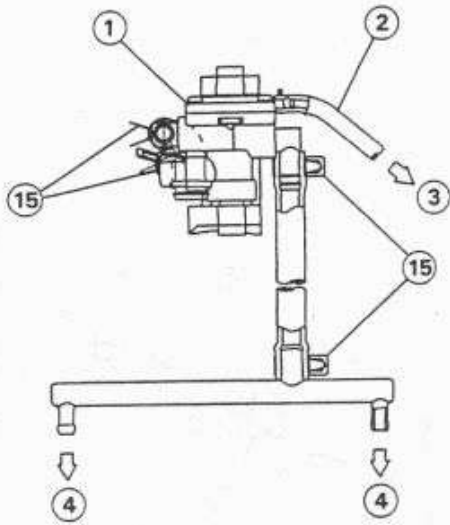

1. Vacuum Valve
2. Vacuum Hose
3. #3 Vacuum Fitting
4. Carburetor Air Vent
5. Air Cleaner Housing
6. Canister
7. Damper
8. Baffle Plate
9. Intake Silencer
10. Vacuum Switch Valve
11. The white mark points upward.
12. Run the vacuum hose between the #1 and #2 carburetor holders.
13. Run the vacuum hose inside the clamp on the #2 carburetor holder.
14. Separator
15. Clamp



# Fuel System

## Table of Contents

Exploded View .....	2-2	Air Cleaner .....	2-20
Specifications .....	2-6	Housing Removal .....	2-20
Throttle Grip and Cables .....	2-8	Housing Installation .....	2-20
Free Play Inspection .....	2-8	Element Removal .....	2-20
Free Play Adjustment .....	2-8	Element Installation .....	2-21
Cable Installation .....	2-8	Element Cleaning and Inspection .....	2-21
Cable Lubrication .....	2-9	Oil Draining .....	2-21
Choke Cable .....	2-10	Fuel Tank .....	2-22
Free Play Inspection .....	2-10	Fuel Tank Removal .....	2-22
Free Play Adjustment .....	2-10	Fuel Tank Installation .....	2-22
Cable Installation .....	2-10	Fuel Tank Inspection .....	2-22
Cable Lubrication .....	2-10	Fuel Tank Cleaning .....	2-23
Carburetors .....	2-11	Fuel Tap Removal .....	2-23
Idle Speed Inspection .....	2-11	Fuel Tap Installation .....	2-23
Idle Speed Adjustment .....	2-11	Fuel Tap Inspection .....	2-24
Synchronization Inspection (ZX750N) .....	2-11	Fuel Pump, Fuel Filter .....	2-25
Synchronization Adjustment (ZX750N) .....	2-12	Fuel Pump Removal .....	2-25
Synchronization Inspection (ZX750P) .....	2-13	Fuel Pump Installation .....	2-25
Synchronization Adjustment (ZX750P) .....	2-13	Fuel Filter Removal .....	2-25
Service Fuel Level Inspection .....	2-14	Fuel Filter Installation .....	2-26
Service Fuel Level Adjustment .....	2-14	Fuel Pump Inspection .....	2-26
Fuel System Cleanliness Inspection .....	2-15	Fuel Filter Inspection .....	2-26
Carburetor Removal .....	2-15	Vacuum Valve .....	2-27
Carburetor Installation .....	2-16	Vacuum Valve Inspection .....	2-27
Carburetor Disassembly/Assembly .....	2-16	Evaporative Emission Control System	
Carburetor Separation/Assembly .....	2-17	(California Model Only) .....	2-28
Carburetor Cleaning .....	2-17	Parts Removal/Installation .....	2-28
Carburetor Inspection .....	2-18	Hose Inspection .....	2-28
High Altitude Performance Adjustment		Separator Inspection .....	2-28
(US model) .....	2-19	Separator Operation Test .....	2-28
Coolant Filter Cleaning		Canister Inspection .....	2-29
(AR, FG, FR, IT, KR, NL, ST, UK) .....	2-19		

Exploded View

ZX750N:

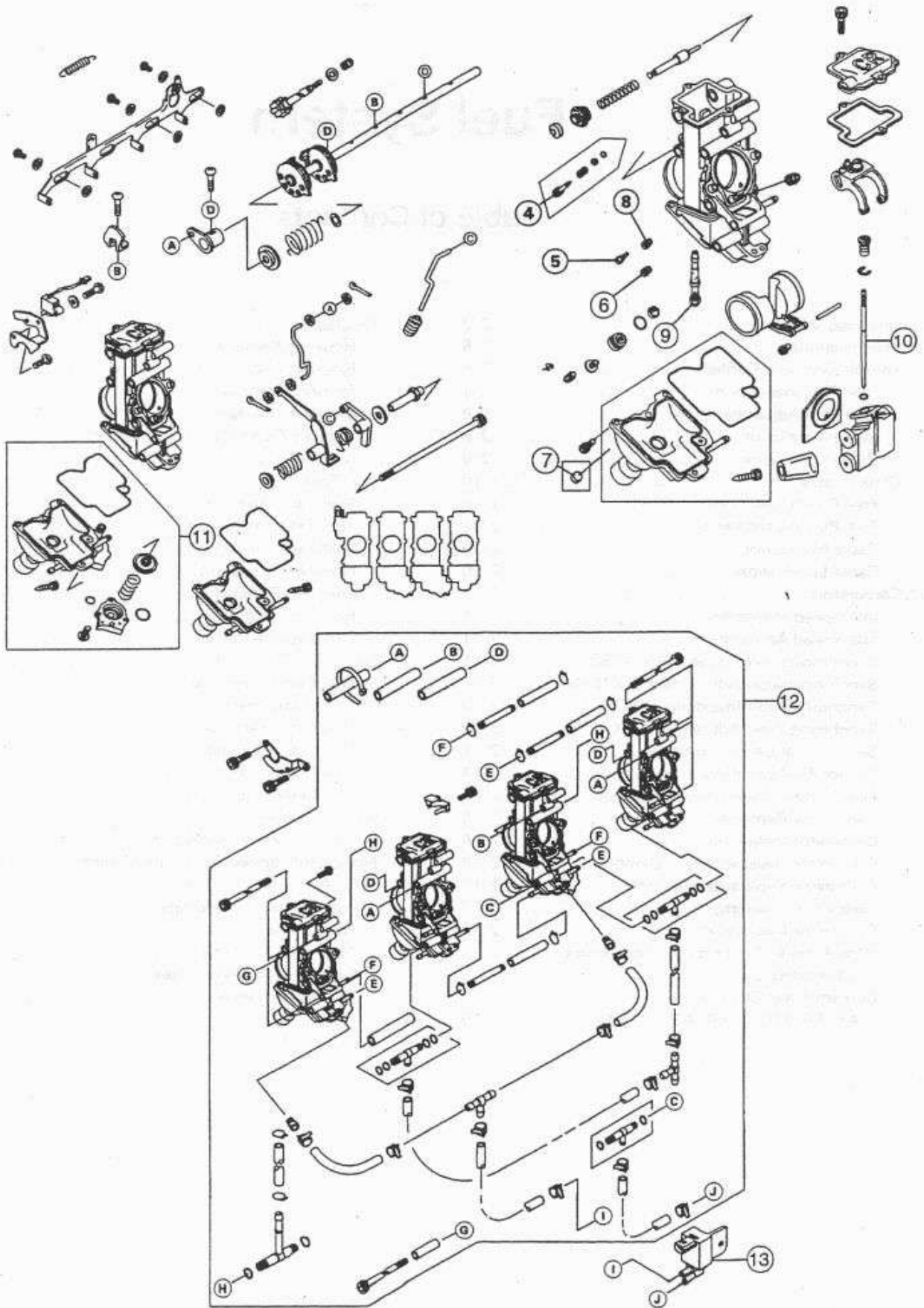

ZX750-N:

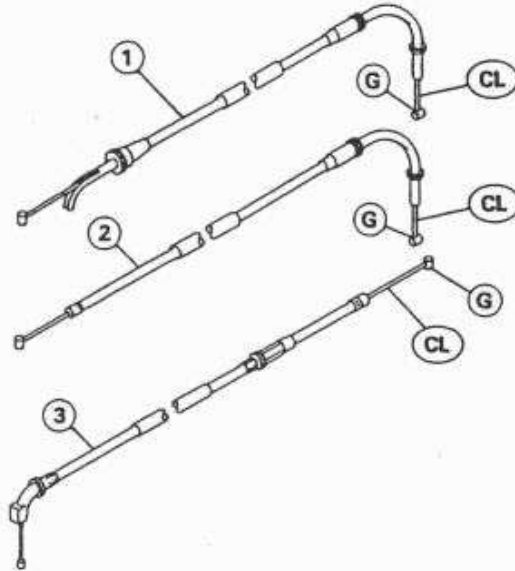

1. Throttle Cable (accelerator)
2. Throttle cable (decelerator)
3. Choke Cable
4. Pilot Screw
5. Pilot (Slow) Jet
6. Main Jet
7. Plug (US, ST)
8. Starter Jet
9. Main Nozzle
10. Jet Needle
11. Accelerator Pump
12. (US, CN) Models
13. Fuel Enricher Solenoid Valve
14. Other than (US, CN) Models

G: Apply grease.  
 GL: Apply cable lubricant.

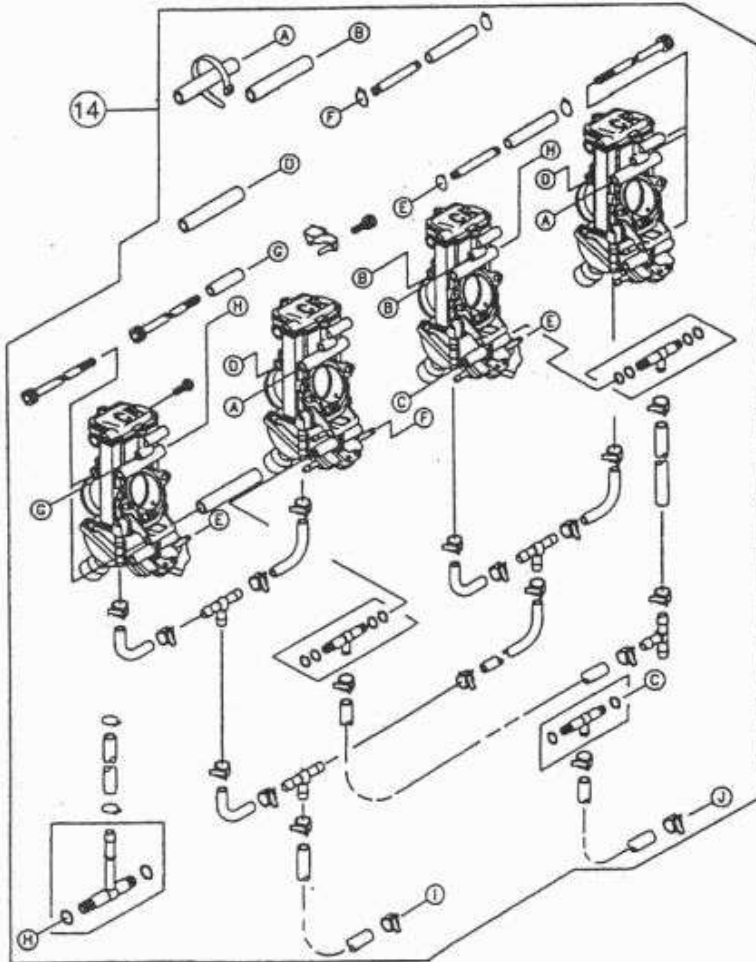

ST: Switzerland  
 US: United States  
 CN: Canada

Fig. 1

- 1. Fuel tank
- 2. Fuel filter
- 3. Fuel pump
- 4. Fuel line
- 5. Fuel injector
- 6. Fuel nozzle
- 7. Fuel valve
- 8. Fuel pressure gauge
- 9. Fuel return line
- 10. Fuel manifold
- 11. Fuel distributor
- 12. Fuel pump drive shaft
- 13. Fuel pump housing
- 14. Fuel pump inlet valve
- 15. Fuel pump outlet valve
- 16. Fuel pump check valve
- 17. Fuel pump filter
- 18. Fuel pump seal
- 19. Fuel pump gasket
- 20. Fuel pump nut
- 21. Fuel pump bolt
- 22. Fuel pump washer
- 23. Fuel pump pin
- 24. Fuel pump cotter pin
- 25. Fuel pump lock washer
- 26. Fuel pump lock nut
- 27. Fuel pump lock bolt
- 28. Fuel pump lock washer
- 29. Fuel pump lock nut
- 30. Fuel pump lock bolt



Fig. 2

Fig. 3

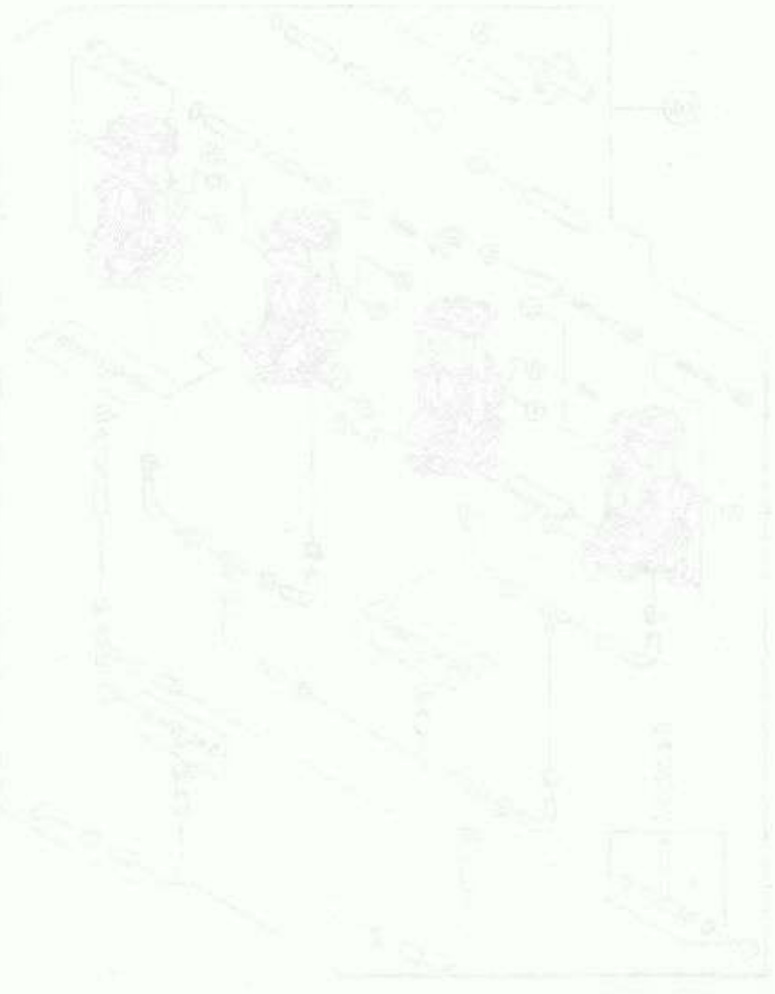

ZX750P

G: Apply grease.  
 GL: Apply cable lubricant.

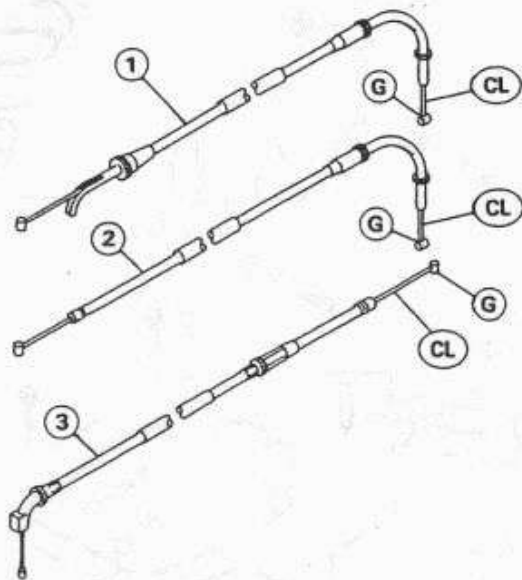

1. Throttle Cable (accelerator)
  2. Thrott Cable (decelerator)
  3. Choke Cable
  4. Pilot Screw
  5. Pilot (Slow) Jet
  6. Air Bleed Pipe
  7. Main Jet
  8. Plug (US, ST)
  9. Jet Needle
- ST: Switzerland  
 US: United States

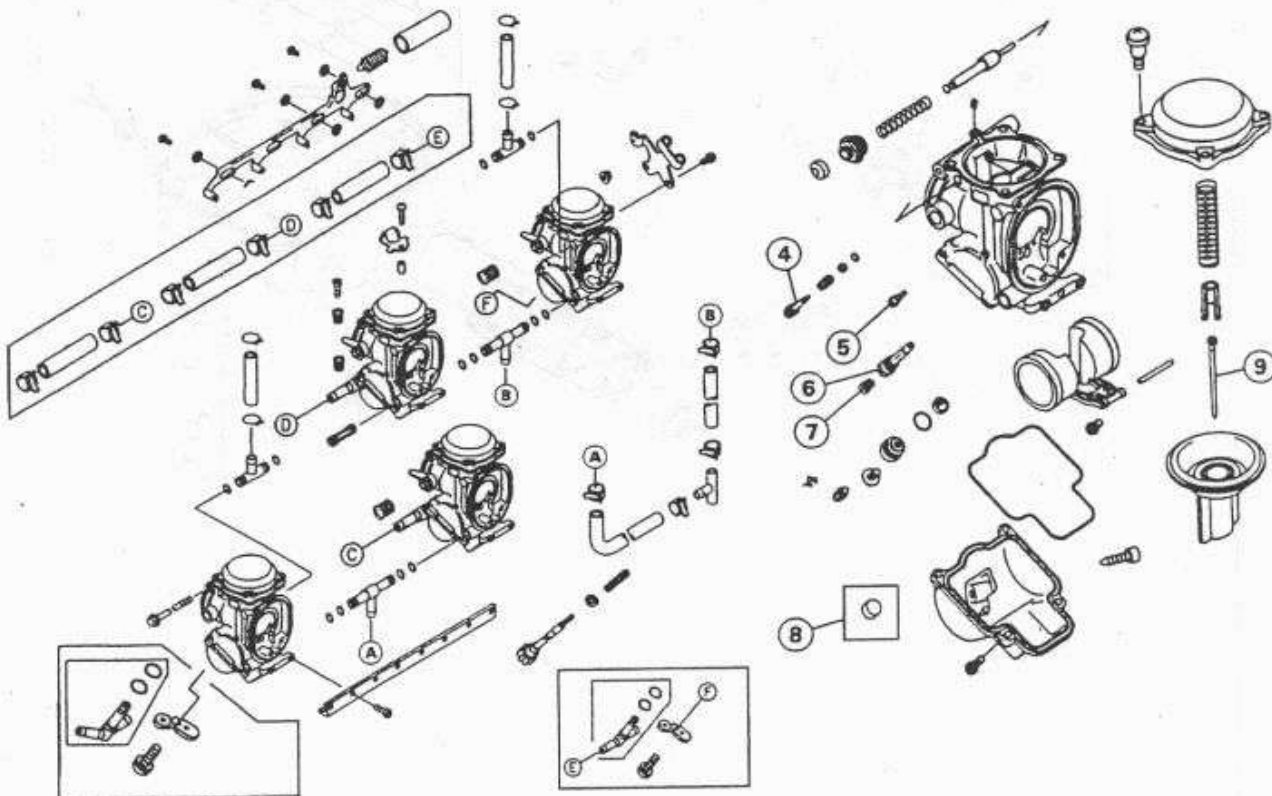

## 2-4 FUEL SYSTEM

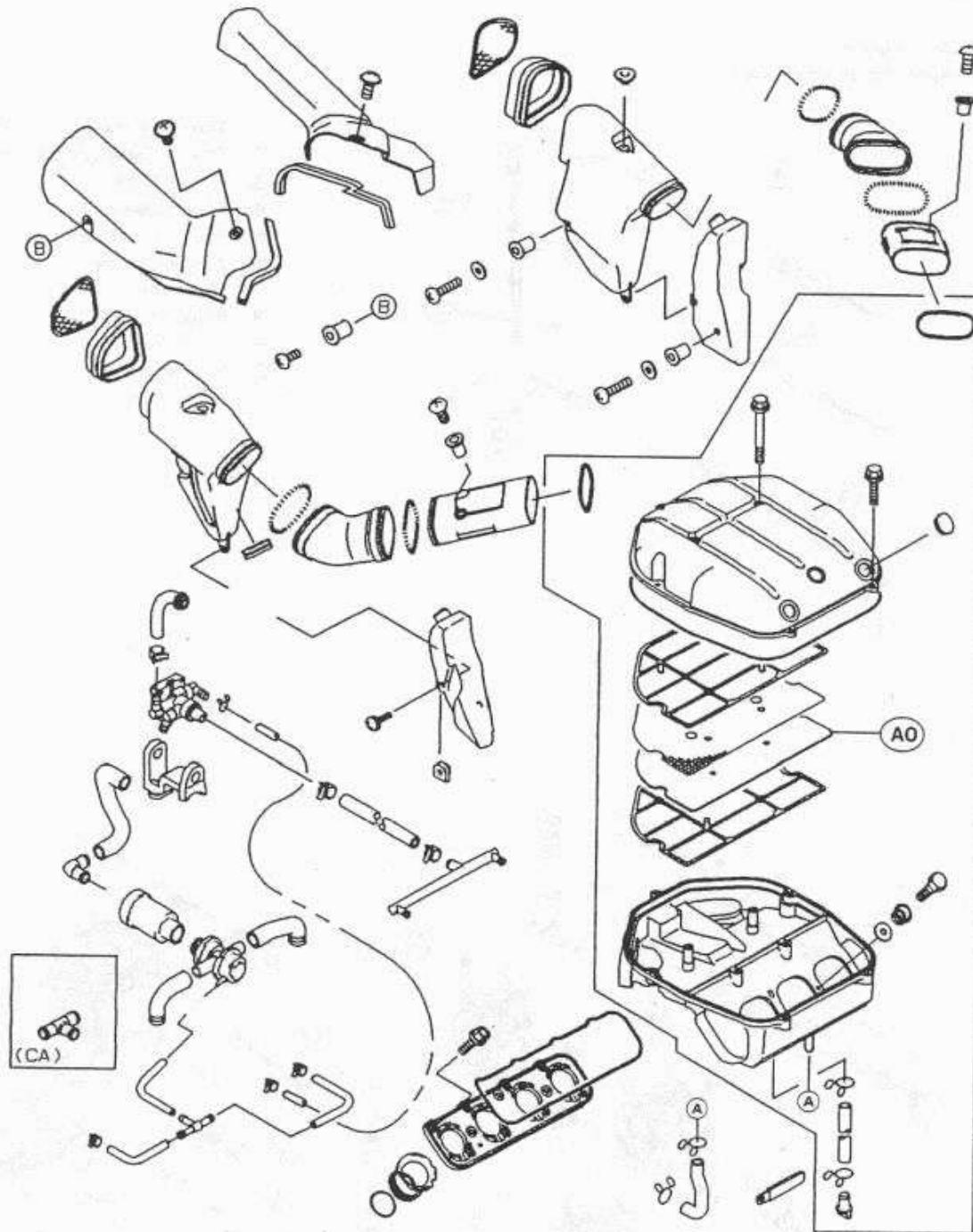

CA: California Model

AO: Apply high-quality-foam-air-filter oil.

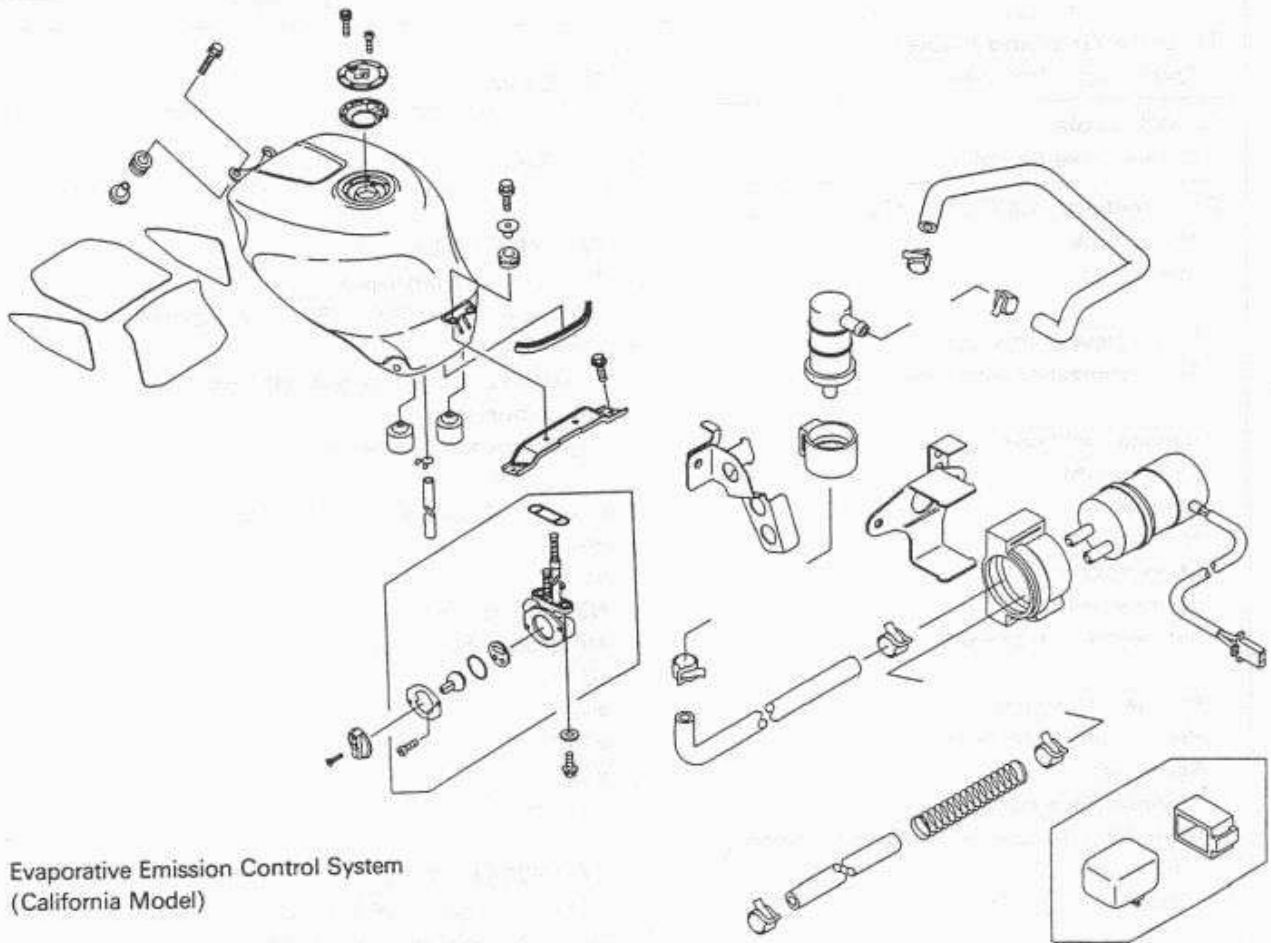

Evaporative Emission Control System  
(California Model)

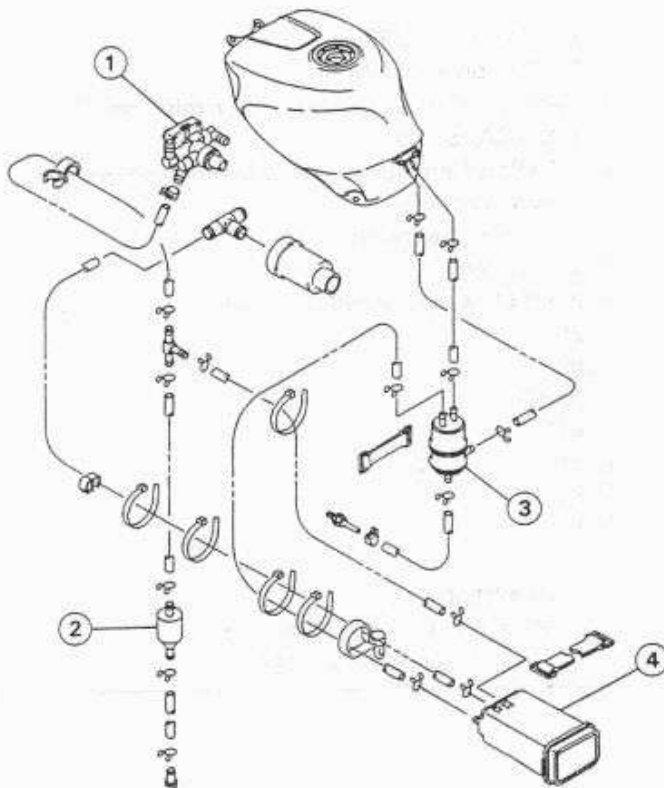

1. Vacuum Valve
2. Catch Tank
3. Separator
4. Canister

## Specifications

Item	Standard
<b>Throttle Grip and Cables:</b> Throttle grip free play	2 ~ 3 mm
<b>Choke Cable:</b> Choke cable free play	2 ~ 3 mm
<b>Carburetors (ZX750N1, N2):</b> Make, type Idle speed  Pilot screw (turns out) Synchronization vacuum  Service fuel level Float height Main jet Main air jet Main nozzle Jet needle mark Jet needle clip position  Pilot jet (slow jet) Pilot air jet (slow air jet) Starter jet Throttle valve cutaway High Altitude Carburetor Specifications (US) Pilot jet Main jet	KEIHIN, FVK-D41 × 4 1100 ± 50 r/min (rpm), (AR, CA, FG) 1300 ± 50 r/min (rpm) 2- $\frac{1}{4}$ , (CA, US) -- 2.7 kPa (2 cmHg) or less difference from #4 carburetor 3 ± 1 mm above the mark 9 ± 2 mm #200 (1, 4 cyl), #210 (2, 3 cyl) #60 #6 N3GF, (US) N3HC 4th groove from top (US) -- #42 #140 #55 2.5 mm  #40 (92064-1125) #195 (1, 4 cyl. 92063-1418) #200 (2, 3 cyl. 92063-1417)
<b>Carburetors (ZX750P1, P2):</b> Make, type Idle speed  Pilot screw (turns out) Synchronization vacuum  Service fuel level Float Height Main jet Main air jet Needle Jet Jet needle mark Pilot jet (slow jet) Pilot air jet (slow air jet) Starter jet Throttle valve angle High Altitude Carburetor Specifications (US) Pilot jet Main jet	KEIHIN, CVK-D38 × 4 1100 ± 50 r/min (rpm), (AR, CA, FG, ST) 1300 ± 50 r/min (rpm) 1- $\frac{1}{4}$ , (CA, ST, US) -- 2.7 kPa (2 cmHg) or less difference between two cylinders 5 ± 1 mm below the mark 13 ± 2 mm #170 (1, 4 cyl), #180 (2, 3 cyl) #50 #6 N14Q #35 #125 #42 11°  #32 (92064-1117) #165 (1,4 cyl. 92063-1347) #175 (2, 3 cyl. 92063-1387)



Item	Standard
<b>Air Cleaner Element Oil:</b> Grade Viscosity	SE, SF, or SG class SAE30

(AR): Austria Model  
 (CA): California Model  
 (FG): Germany Model

(ST): Switzerland Model  
 (US): U.S. Model

- Special Tool – Fuel Level Gauge: 57001-1017**  
**Carburetor Drain Plug Wrench, Hex 3: 57001-1269**  
**Fork Oil Level Gauge: 57001-1290**  
**Pilot Screw Adjuster, C: 57001-1292**  
**Pilot Screw Adjuster Adapter,  $\phi$ 5: 57001-1372**  
**Pilot Screw Adjuster Driver: 57001-1373**  
**Vacuum Gauge: 57001-1369**  
**Vacuum Gauge Bolt: 92150-1161 (as required)**  
**Vacuum Gauge Bolt Washer: 92022-304 (as required)**  
**Pressure Cable Luber: K56019-021**



## 2-8 FUEL SYSTEM

### Throttle Grip and Cables

#### Free Play Inspection

- Check the throttle grip free play [A].
- ★ If the free play is incorrect, adjust the throttle cable.

#### Throttle Grip Free Play

Standard: 2 ~ 3 mm

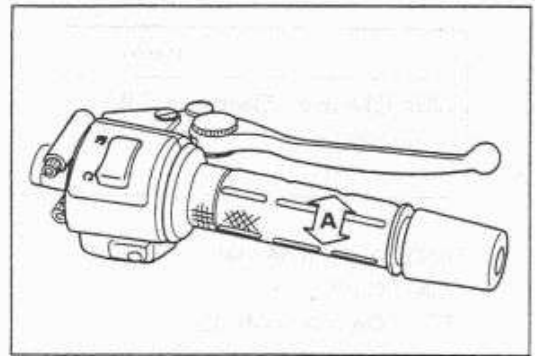

#### Free Play Adjustment

- Loosen the locknut [A].
- Turn the adjuster [B] until the proper amount of free play can be obtained.
- Tighten the locknut securely.
- ★ If the proper amount of free play cannot be obtained by using the adjuster only, use the adjusters at the carburetors side.
- Loosen the locknut, and screw the adjuster at the upper end of the accelerator cable all the way in.
- Tighten the locknut securely.

#### ● Remove:

Fuel Tank (ZX750N, see Fuel Tank Removal)

Air Cleaner Housing (ZX750P, see Air Cleaner Housing Removal)

- Loosen the locknuts [A] at the middle part of the accelerator cable.
- Turn the adjusters [B] until the proper amount of throttle grip free play is obtained.
- Tighten the locknuts securely.
- ★ If the proper amount of free play can not be obtained in the adjustable range of the adjuster, use the adjuster at the upper end of the accelerator cable again.

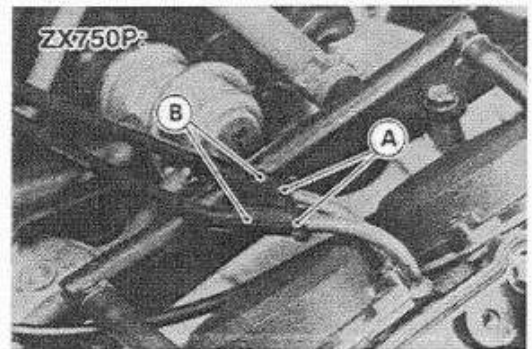
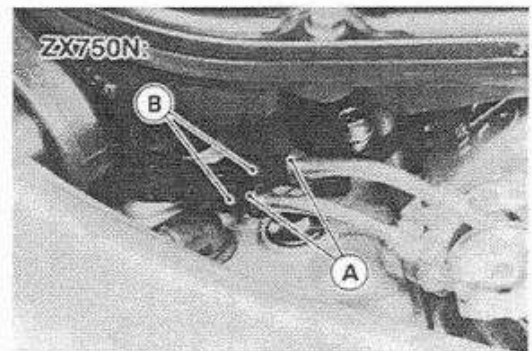
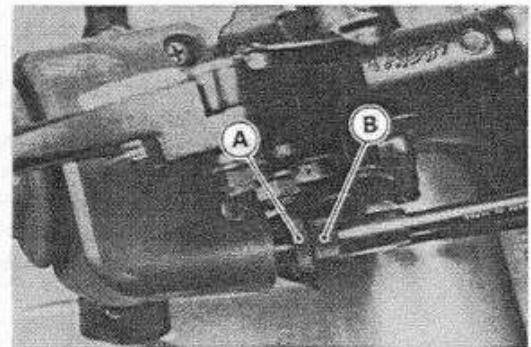

#### Cable Installation

- Install the throttle cables in accordance with Cable Routing section in General Information chapter.
- Install the lower ends of the throttle cables in the cable bracket on the carburetor after installing the upper ends of the throttle cables in the grip.
- After installation, adjust each cable properly.

#### ▲WARNING

Operation with incorrectly routed or improperly adjusted cables could result in an unsafe riding condition.

### *Cable Lubrication*

Whenever the cable is removed, lubricate the throttle cable as follows:

- Apply a thin coating of grease to the cable lower ends.
- Lubricate the cable with a penetrating rust inhibitor.

**Special Tool – Pressure Cable Luber: K56019-021 [A]**

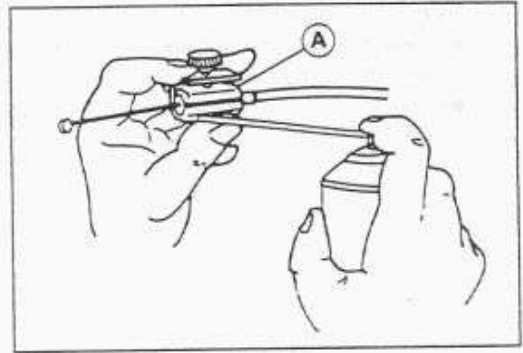

## 2-10 FUEL SYSTEM

### Choke Cable

#### Free Play Inspection

- Check that the choke inner cable slides smoothly by moving the choke lever [A] to the front and rear.
- ★ If there is any irregularity, check the choke cable play [B].

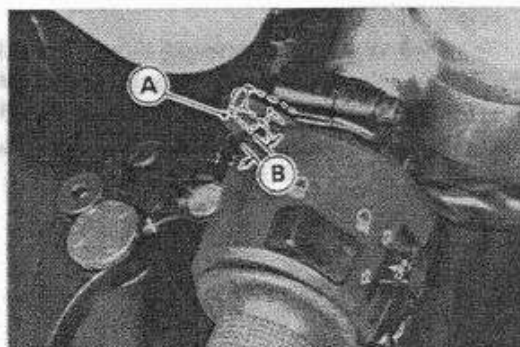

- Push the choke lever all the way to the front.
- Check choke cable free play [A].
- Determine the amount of choke cable play at the choke lever. Pull the choke lever until the starter plunger lever [B] at the carburetor touches the starter plunger [C]; the amount of choke lever lower end travel is the amount of choke cable play.
- ★ If the free play is incorrect, adjust the choke cable.

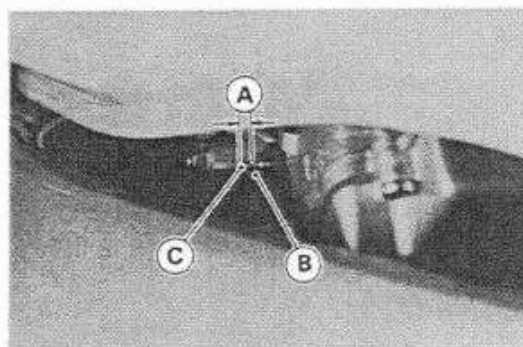

#### Choke Cable Free Play

Standard: 2 ~ 3 mm

#### Free Play Adjustment

- Remove the fuel tank and air cleaner housing (see Fuel Tank Removal and Air Cleaner Housing Removal).
- Loosen the locknut [A], and turn the adjuster [B] until the cable has the proper amount of free play.
- Tighten the locknut securely.

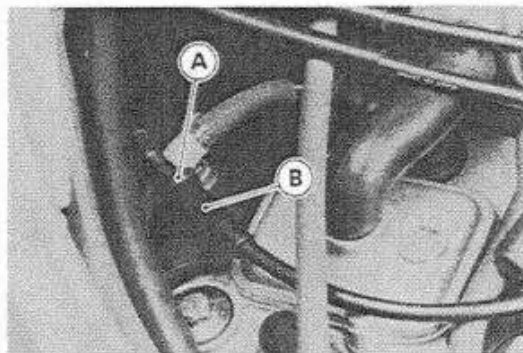

#### Cable Installation

- Install the choke cable in accordance with the Cable Routing section in the General Information chapter.
- After installation, adjust the cable properly.

#### Cable Lubrication

Whenever the choke cable is removed, lubricate the choke cable as follows:

- Apply a thin coating of grease to the cable upper end.
- Lubricate the cable with a penetrating rust inhibitor.

Special Tool – Pressure Cable Luber: K56019-021 [A]

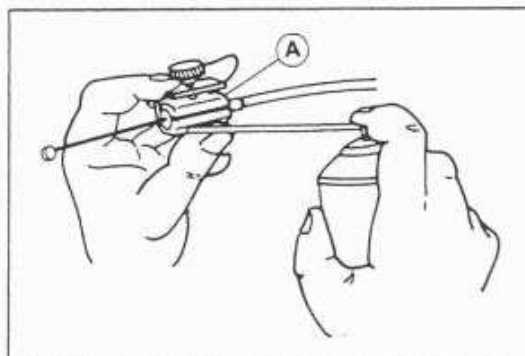

## Carburetors

### Idle Speed Inspection

#### CAUTION

For ZX750N model, do not open and close the throttle excessively. The accelerator pump can flood the engine, and cause starting difficulty.

- Start the engine and warm it up thoroughly.

#### CAUTION

For ZX750N model, do not open and close the throttle excessively when warming the engine. The accelerator pump can flood the engine, and cause the spark plug fouling.

- With the engine idling, turn the handlebar to both sides.
- ★ If handlebar movement changes the idle speed, the throttle cables may be improperly adjusted or incorrectly routed, or damaged. Be sure to correct any of these conditions before riding (see Cable Routing section in General Information chapter).

#### ▲WARNING

Operation with improperly adjusted, incorrectly routed, or damaged cables could result in an unsafe riding condition.

- Check idle speed.
- ★ If the idle speed is out of the specified range, adjust it.

#### Idle Speed

Standard: 1,100 ± 50 r/min (rpm)  
(California, Swiss, Austria and Germany Models)  
1,300 ± 50 r/min (rpm)

### Idle Speed Adjustment

- Start the engine and warm it up thoroughly.
- Turn the adjusting screw [A] until the idle speed is correct.
- Open and close the throttle a few times to make sure that the idle speed is within the specified range. Readjust if necessary.

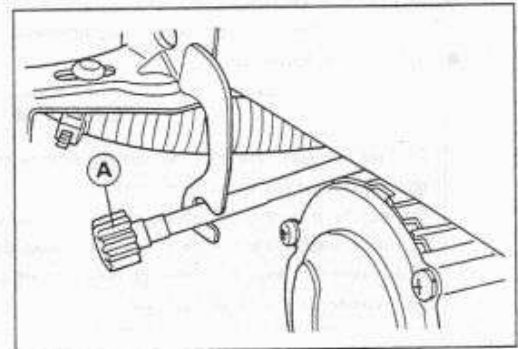

### Synchronization Inspection (ZX750N)

- Remove the fuel tank (see Fuel Tank Removal).
- Connect a fuel tank to the carburetors with a suitable hose.
- Screw in the idle adjusting screw about three threads. This is the point where the adjusting screw is about to move the pulley.

#### CAUTION

Do not open and close the throttle excessively. The accelerator pump can flood the engine, and cause starting difficulty.

- Start the engine and warm it up thoroughly.

**CAUTION**

Do not open and close the throttle excessively when warming the engine. The accelerator pump can flood the engine, and cause spark plug fouling.

- Check idle speed.
- Remove the air cleaner housing and the carburetors.
- For the models other than the California model, remove the inlet pipe plug [A] on the #2 cylinder head, and install the vacuum gauge bolt (92150-1161) and washer (92022-304).
- Attach the vacuum gauge [A] to the bolts on the cylinder head.

**Special Tool – Vacuum Gauge: 57001-1369**

- Install the carburetors.
- Start the engine and let it idle to measure the carburetor intake vacuum.
- ★ If the vacuum is incorrect, adjust the synchronization.

**Carburetor Synchronization Vacuum**

**Standard: Less than 2.7 kPa (2 cmHg) difference from the #4 carburetors.**

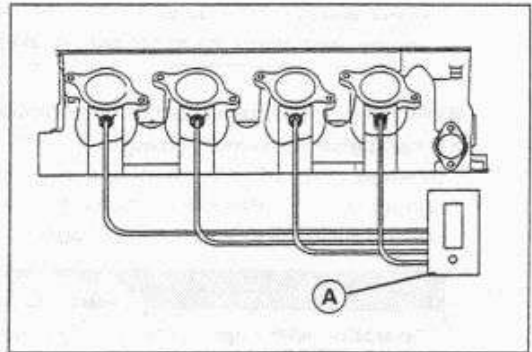
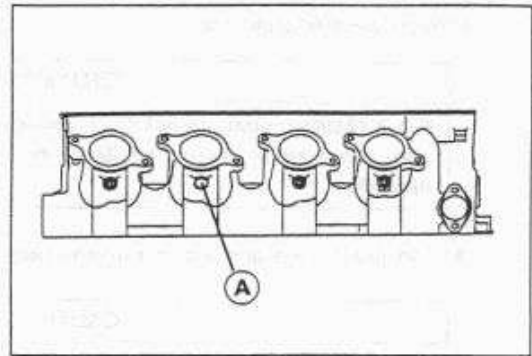

**Synchronization Adjustment (ZX750N)**

- Remove the top covers [A].
- Do not remove the #4 top cover [B].

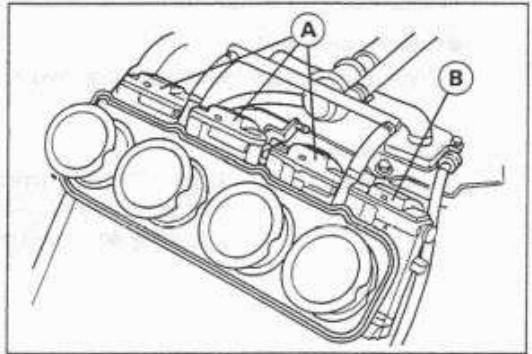

- Loosen the locknuts [A] and turn the adjusting screws [B].
- Turning in the balance adjusting screw closes the throttle valve.
- Tighten the locknut.

**CAUTION**

Do not tamper with the adjusting screw of the #4 carburetor which is the standard for synchronization.

Do not turn in the adjusting screws too far. Do not make the throttle valve to carburetor bore clearance less than the standard carburetor. This upsets the throttle pulley position, and the standard (#4) carburetor will not idle properly.

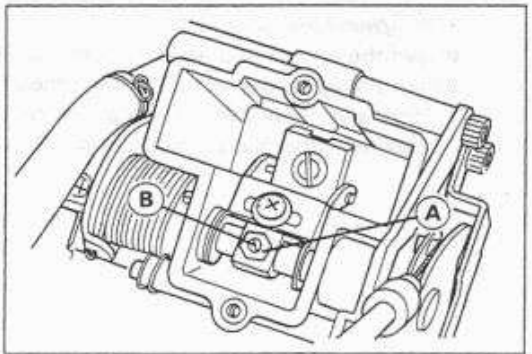

- ★ If the carburetor synchronization cannot be obtained by using the adjusting screws, remove the carburetor and check for dirt, blockage, or throttle valve clearance.
- Adjust each clearance [A] between the throttle valve [B] and the bottom [C] of the carburetor bore so that the clearance is the same as the #4 carburetor's clearance using the adjusting screws above.

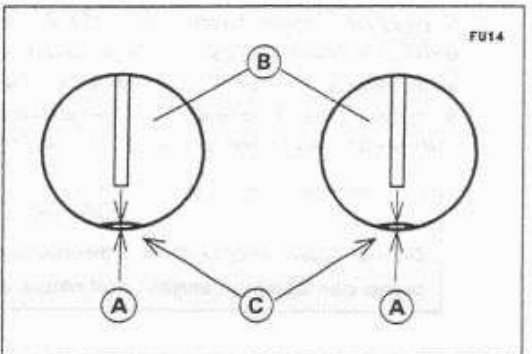

FU14

- Check the pilot screw settings using a screwdriver.
- Check the carburetor synchronization again.

**NOTE**

○ Do not turn the pilot screws carelessly. You may cause poor running at low engine speed.

- For the models other than the California model, remove the vacuum gauge bolts and install the inlet pipe plug and washer.
- Check idle speed.

**Synchronization Inspection (ZX750P)**

- Remove the fuel tank (see Fuel Tank Removal).
- Supply fuel to the carburetors with an auxiliary fuel tank.
- Start the engine and warm it up thoroughly.
- Check idle speed.
- For the models other than the California model, remove the inlet pipe plug on the #2 cylinder head, and install the vacuum gauge bolt (92150-1161) and washers (92022-304).
- Attach the vacuum gauge [A] to the bolts [B] on the cylinder head.

**Special Tool – Vacuum Gauge: 57001-1369**

- Start the engine and let it idle to measure the carburetor intake vacuum.
- ★ If the vacuum is incorrect, adjust the synchronization.

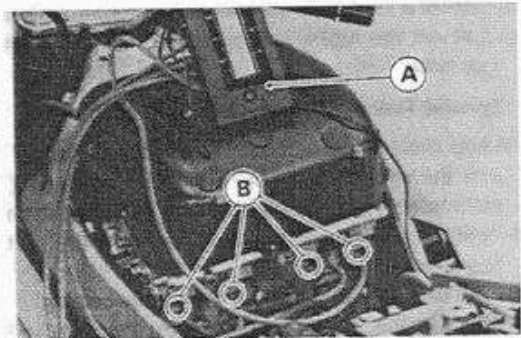

**Carburetor Synchronization Vacuum**

**Standard: Less than 2.7 kPa (2 cmHg) difference between any two carburetors.**

**Synchronization Adjustment (ZX750P)**

- Turn the adjusting screw to synchronize the carburetors.
- First synchronize the left two and then the right two carburetors by means of the left and right adjusting screws [A, B]. Then synchronize the left two carburetors and the right two carburetors using the center adjusting screw [C].
- ★ If the carburetor synchronization cannot be obtained by using the adjusting screws, check for dirt or blockage, and then check the pilot screw settings.

**Special Tool – Pilot Screw Adjuster, C: 57001-1292  
Pilot Screw Adjuster Adapter, φ5: 57001-1372  
Pilot Screw Adjuster Driver: 57001-1373**

- Check the carburetor synchronization again.

**NOTE**

○ Do not turn the pilot screws carelessly during carburetor synchronization. You may cause poor running at low engine speed.

- For the models other than the California model, remove the vacuum gauge bolt and install the inlet pipe plug and washer.
- Check idle speed.

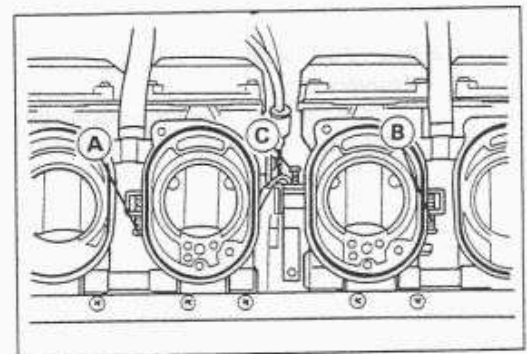

### Service Fuel Level Inspection

#### ⚠ WARNING

Gasoline is extremely flammable and can be explosive under certain conditions. Turn the ignition switch OFF. Do not smoke. Make sure the area is well-ventilated and free from any source of flame or sparks; this includes any appliance with a pilot light.

- Situate the motorcycle so that it is perpendicular to the ground.
- Remove the fuel tank (see Fuel Tank Removal).
- Prepare an auxiliary fuel tank and connect the fuel hose to the carburetors.
- Prepare a fuel hose (6 mm out diameter and about 300 mm long).
- Connect the fuel level gauge [A] to the carburetor float bowl with the fuel hose.

#### Special Tool – Fuel Level Gauge: 57001-1017

- Hold the gauge vertically against the side of the carburetor body so that the middle line (ZX750N) [B], top line (ZX750P) [C] is several millimeters higher than the mark [D] on the carburetor body.
- Feed fuel to the carburetor, then turn the carburetor drain plug out a few turns.
- Wait until the fuel level in the gauge settles.
- Keeping the gauge vertical, align the middle line or top line with the mark.

#### NOTE

○ Do not lower the middle line or top line below the mark of the carburetor body. If the gauge is lowered and then raised again, the fuel level measured shows somewhat higher than the actual fuel level. If the gauge is lowered too far, dump the fuel into a suitable container and start the procedure over again.

- Read the fuel level [E] in the gauge and compare to the specification.
- Screw in the carburetor drain plug.
- Stop feeding and remove the fuel level gauge.
- ★ If the fuel level is incorrect, adjust it (see Service Fuel Level Adjustment).

#### Service Fuel Level

##### Standard:

ZX750N:	$3 \pm 1$ mm above the mark on the carburetor body
ZX750P:	$5 \pm 1$ mm below the mark on the carburetor body

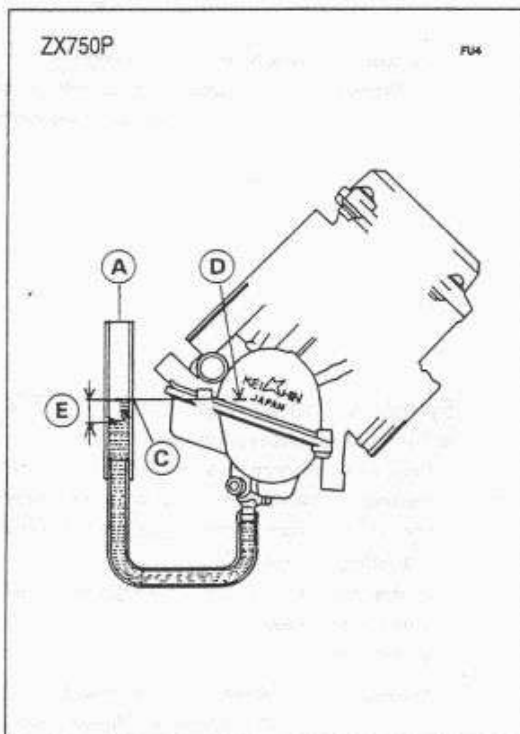
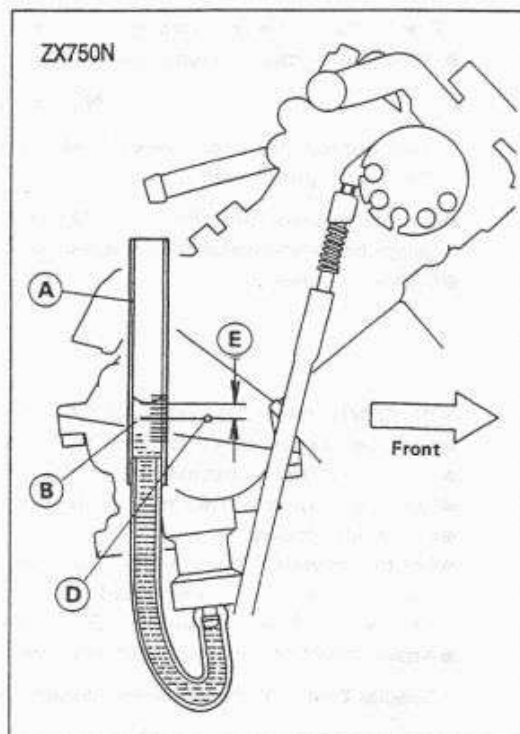

### Service Fuel Level Adjustment

#### ⚠ WARNING

Gasoline is extremely flammable and can be explosive under certain conditions. Turn the ignition switch OFF. Do not smoke. Make sure the area is well-ventilated and free from any source of flame or sparks; this includes any appliance with a pilot light.

- Remove the carburetor, and drain the fuel into a suitable container.
- Remove the float bowl.
- Remove the screw [A] and take out the float [B].

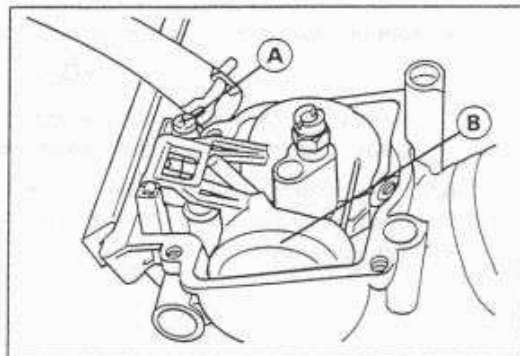



- Bend the tang [A] on the float arm very slightly to change the float height. Increasing the float height lowers the fuel level and decreasing the float height raises the fuel level.

**Float Height**

**Standard:**

- ZX750N: 9 ± 2 mm
- ZX750P: 13 ± 2 mm

**NOTE**

- Do not push the needle rod [A] in during the float height measurement [B].
- Assemble the carburetor, and recheck the fuel level.
- ★ If the fuel level cannot be adjusted by this method, the float or the float valve [C] is damaged.

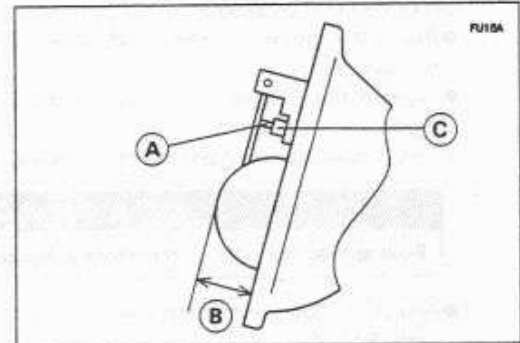
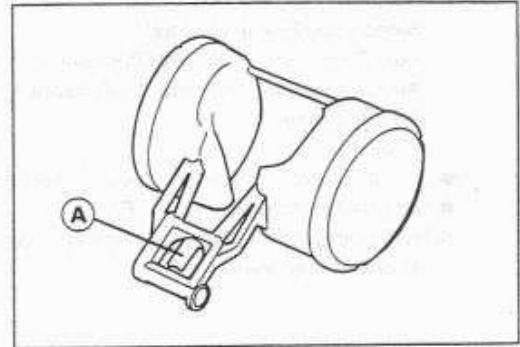

*Fuel System Cleanliness Inspection*

**▲WARNING**

Gasoline is extremely flammable and can be explosive under certain conditions. Turn the ignition switch OFF. Do not smoke. Make sure the area is well-ventilated and free from any source of flame or sparks; this includes any appliance with a pilot light.

- Remove the fuel tank (see Fuel Tank Removal)
- Connect a suitable hose [A] to the fitting at the bottom of each carburetor float bowl.
- Run the lower ends of the hoses into a suitable container.
- Turn out each drain plug [B] a few turns and drain the float bowls.

**Special Tool – Carburetor Drain Plug Wrench, Hex 3: 57001-1269**

- Check to see if water or dirt comes out.
- Tighten the drain plugs.
- ★ If any water or dirt appears during the above inspection, clean the fuel system (see Carburetor Cleaning and Fuel Tank Cleaning).

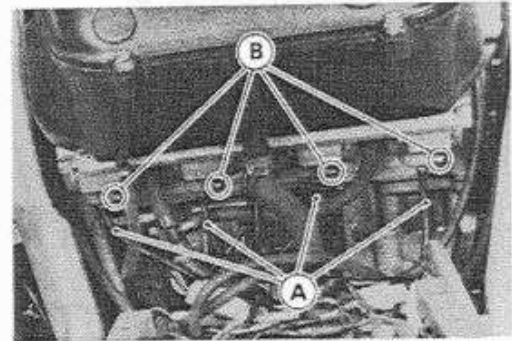

*Carburetor Removal*

**▲WARNING**

Gasoline is extremely flammable and can be explosive under certain conditions. Turn the ignition switch OFF. Do not smoke. Make sure the area is well-ventilated and free from any source of flame or sparks; this includes any appliance with a pilot light.

- Remove:
  - Seats (see Frame chapter)
  - Fuel Tank (see Fuel Tank Removal)
  - Air Cleaner Housing (see Air Cleaner Housing Removal)
  - Choke Cable
  - Fuel Hose
- Loosen the carburetor clamps [A], and remove the carburetors.
- Remove the throttle cables [B].
- Stuff pieces of lint-free, clean cloth into the carburetor holders to keep dirt out of the engine.

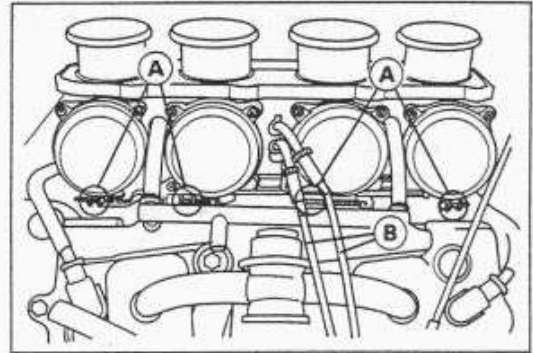

### Carburetor Installation

- Route the cables, harness, and hoses correctly (see General Information chapter).
- Tighten the clamps for the carburetor holders at the position in the figure.
- Check fuel leakage from the carburetors.

#### ▲WARNING

**Fuel spilled from the carburetors is hazardous.**

- Adjust the following items if necessary.
  - Idle Speed
  - Carburetor Synchronization
  - Throttle Cables
  - Choke Cable

#### ZX750N :

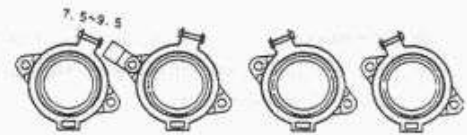

#### ZX750P :

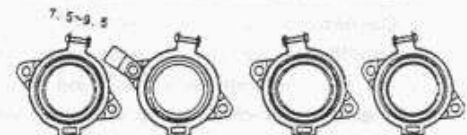

### Carburetor Disassembly/Assembly

#### ▲WARNING

**Gasoline is extremely flammable and can be explosive under certain conditions. Turn the ignition switch OFF. Do not smoke. Make sure the area is well-ventilated and free from any source of flame or sparks; this includes any appliance with a pilot light.**

- To remove the jet needle for the ZX750N, remove the plug [A].
- For the US and Swiss models, remove the pilot screw plug as follows:
  - Punch a hole in the plug and pry there with an awl or other suitable tool.
  - Turn in the pilot screw and count the number of turns until it seats fully but not tightly, and then remove the screw. Use this number of turns to set the screw to its original position during assembly.
- After installing the upper chamber cover, check that the vacuum piston slides up and down smoothly without binding in the carburetor bore.

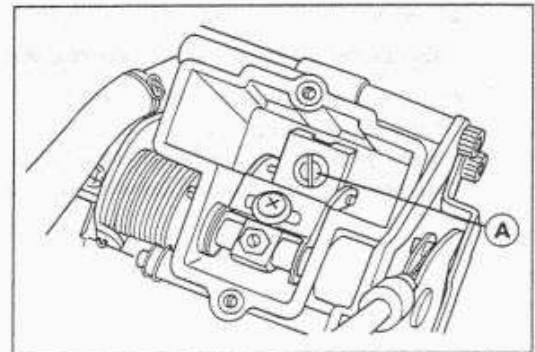

#### CAUTION

**During carburetor disassembly, be careful not to damage the diaphragm. Never use a sharp edge to remove the diaphragm.**

- Turn in the pilot screw [A] fully but not tightly, and then back it out the same number of turns counted during disassembly.
- A carburetor has different "turns out" of the pilot screw for each individual unit. When setting the pilot screw, use the "turns out" determined during disassembly. Use the specifications in this manual only if the original number is unknown.
- For the US and Swiss models, install the pilot screw plug as follows:
  - Install a new plug [B] in the pilot screw hole, and apply a small amount of a bonding agent [C] to the circumference of the plug to fix the plug.

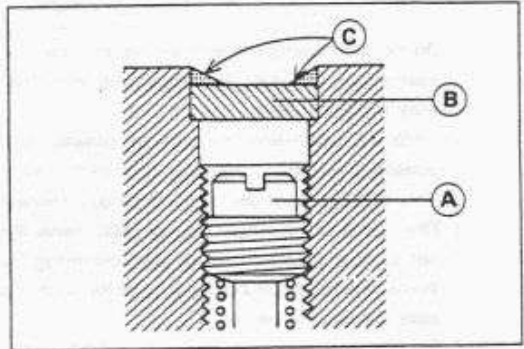

**CAUTION**

Do not apply too much bonding agent to the plug or the pilot screw itself may be fixed.

- Slip the needle through the hole in the center of the vacuum piston, and put the spring seat [A] on the top of the needle. Turn the seat so that it does not block the hole [B] at the bottom of the vacuum piston.

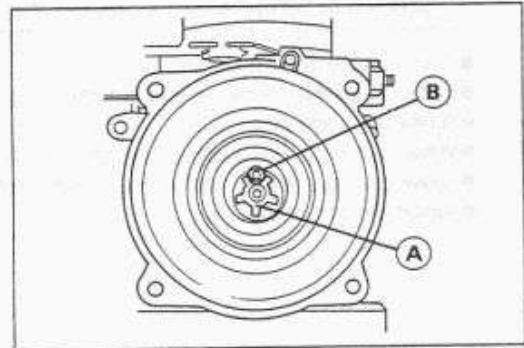

### Carburetor Separation/Assembly

- Read the WARNING in Carburetor Disassembly/Assembly.
- The center lines of the carburetor bores must be parallel both horizontally and vertically. If they are not, loosen the mounting screws and align the carburetors on a flat surface. Retighten the mounting screws.
- After assembling the choke mechanism, check to see that the starter plunger lever slides right to left smoothly without abnormal friction.

**CAUTION**

Fuel mixture trouble could result if the starter plunger lever does not seat properly in its rest position after the choke lever is returned.

- Visually synchronize the throttle (butterfly) valves.
  - Check to see that all throttle valves open and close smoothly without binding when turning the pulley.
  - Visually check the clearance [A] between the throttle valve and the carburetor bore in each carburetor.
- ★ If there is a difference between any two carburetors, turn the balance adjusting screw(s) [B] to obtain the same clearance.

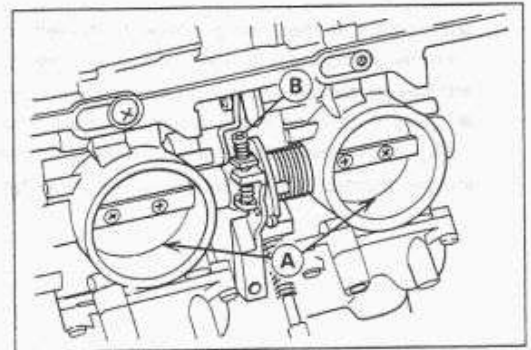

### Carburetor Cleaning

**⚠WARNING**

Clean the carburetors in a well-ventilated area, and take care that there is no sparks or flame anywhere near the working area; this includes any appliance with a pilot light. Because of the danger of highly flammable liquids, do not use gasoline or low flash-point solvents to clean the carburetors.

### CAUTION

Do not use compressed air on an assembled carburetor, or the floats may be crushed by the pressure, and the vacuum piston diaphragms may be damaged.

Remove as many rubber or plastic parts from the carburetor as possible before cleaning the carburetor with a cleaning solution. This will prevent damage to or deterioration of the parts.

The carburetor body has plastic parts that cannot be removed. Do not use a strong carburetor cleaning solution which could attack these parts; instead, use a mild high flash-point cleaning solution safe for plastic parts.

Do not use wire or any other hard instrument to clean carburetor parts, especially jets, as they may be damaged.

- Disassemble the carburetor.
- Immerse all the metal parts in a carburetor cleaning solution.
- Rinse the parts in water.
- When the parts are clean, dry them with compressed air.
- Blow through the air and fuel passages with compressed air.
- Assemble the carburetor.

### Carburetor Inspection

#### ⚠ WARNING

Gasoline is extremely flammable and can be explosive under certain conditions. Turn the ignition switch OFF. Do not smoke. Make sure the area is well-ventilated and free from any source of flame or sparks; this includes any appliance with a pilot light.

- Remove the carburetors.
- Before disassembling the carburetors, check the fuel level (see Fuel Level Inspection).
- ★ If the fuel level is incorrect, inspect the rest of the carburetor before correcting it.
- Move the starter plunger lever to the left and release it to check that the starter plungers move smoothly and return by spring tension.
- ★ If the starter plungers do not work properly, replace the carburetors.
- Turn the throttle cable pulley to check that the throttle butterfly valves [A] move smoothly and return by spring tension.
- ★ If the throttle valves do not move smoothly, replace the carburetors.

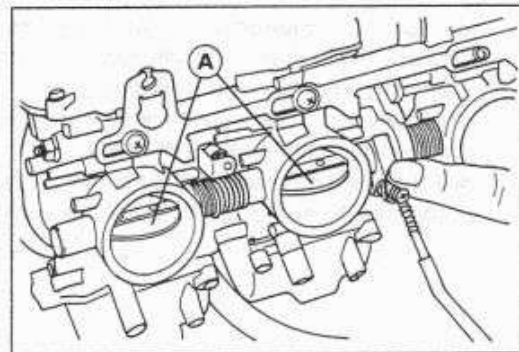

- Disassemble the carburetors.
- Clean the carburetors.
- Check that the O-rings on the float bowl and pilot screw and the diaphragm on the vacuum piston are in good condition.
- ★ If any of the O-rings or diaphragms are not in good condition, replace them.
- Check the plastic tip [A] of the float valve needle [B]. It should be smooth, without any grooves, scratches, or tears.
- ★ If the plastic tip is damaged [C], replace the needle.
- Push the rod [D] in the other end of the float valve needle, and then release it.
- ★ If the rod does not spring out, replace the needle.

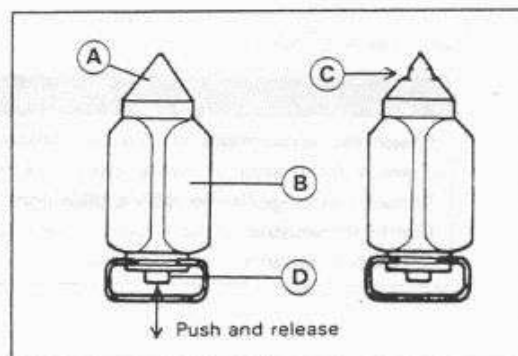

- Check the tapered portion [A] of the pilot screw [B] for wear or damage.
- ★ If the pilot screw is worn or damaged on the tapered portion, it will prevent the engine from idling smoothly. Replace it.

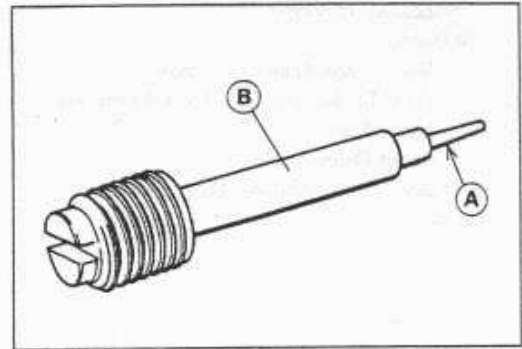

- Check that the vacuum piston [A] moves smoothly in the carburetor body. The surface of the piston must not be excessively worn.
- ★ If the vacuum piston does not move smoothly, or if it is very loose in carburetor body, replace the carburetor.

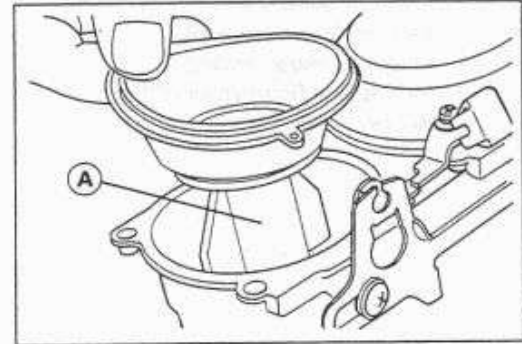

**High Altitude Performance Adjustment (US model)**

- To improve the EMISSION CONTROL PERFORMANCE of vehicle operated above **4000 feet**, Kawasaki recommends the following Environmental Protection Agency (EPA) approved modification.
- Change the main jet and pilot jet for high altitude use.

**High Altitude Carburetor Specifications**

**ZX750N:**

- Pilot Jet: #40 (92064-1125)
- Main Jet: #195 (1, 4 cyl. 92063-1418)
- #200 (2, 3 cyl. 92063-1417)

**ZX750P:**

- Pilot Jet: #32 (92064-1117)
- Main Jet: #165 (1, 4 cyl. 92063-1347)
- #175 (2, 3 cyl. 92063-1387)

**Coolant Filter Cleaning (AR, FG, FR, IT, KR, NL, ST, UK)**

Before winter season starts, clean the filter of carburetor system.

- Remove the lower fairings (see Frame chapter).
- Drain the coolant (see Cooling System chapter).
- Remove the filter [A] from the cooling hoses of carburetor system.
- Blow off dirt and sediment on the filter with compressed air.

- [B] Thermostat
- [C] Thick Cooling Hose
- [D] Thin Cooling Hose
- [E] Connect to Carburetor

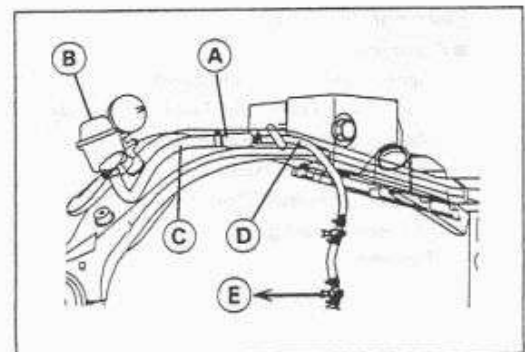

## Air Cleaner

### Housing Removal

● Remove:

- Seats (see Frame chapter)
- Fuel Tank (see Fuel Tank Removal)
- Inner Fairing
- Joint Duct [A]
- Screw [B] and Air Duct [C]

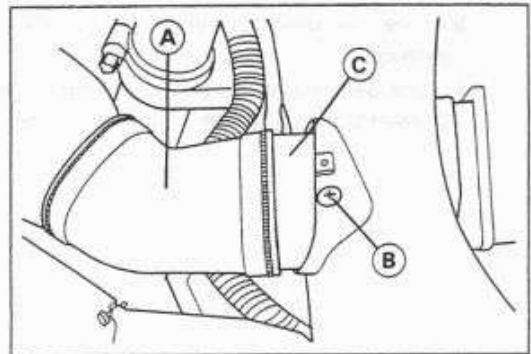

- Vacuum Switch Valve Hose [A]
- Vacuum Valve Hose [B]
- Engine Breather Hose [C]
- Air Cleaner Drain Hose [D]
- Rubber Plugs [E]

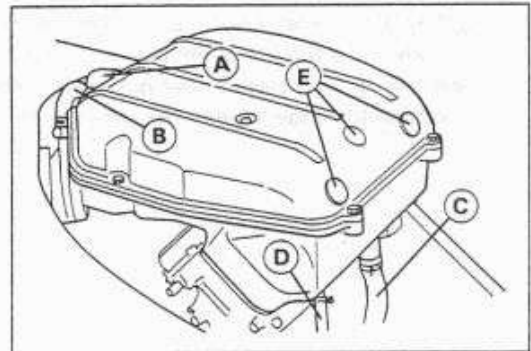

- Mounting Bolts [A]
- Air Cleaner Housing [B]

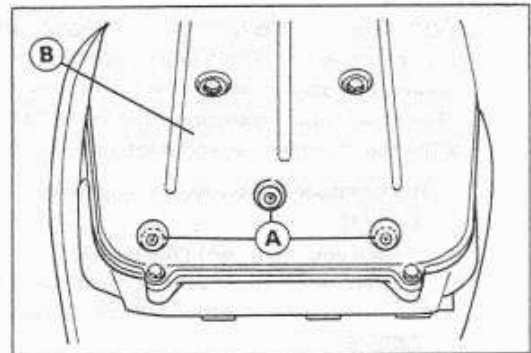

### Housing Installation

● Be sure to fit the following hoses.

- Engine Breather Hose
- Air Cleaner Drain Hoses
- Vacuum Switch Valve Hose
- Vacuum Valve Hose

● Install the rubber plugs in place.

- Install the air duct [A] and joint duct [B] so that the arrow marks [C] faces forwards.

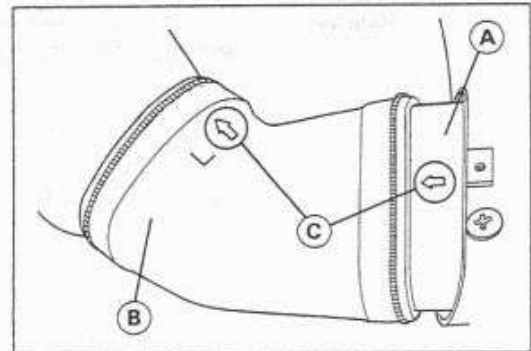

### Element Removal

● Remove:

- Seats (see Frame chapter)
- Fuel Tank (see Fuel Tank Removal)
- Vacuum Switch Valve Hose [A]
- Vacuum Valve Hose [B]
- Upper Housing Mounting Bolts [C]
- Upper Housing [D]
- Element

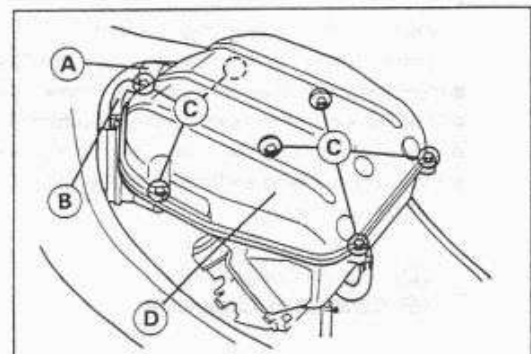

### Element Installation

- Install the element [A] with the foam element side (gray) facing up.
- Install the screen [B] above the element.

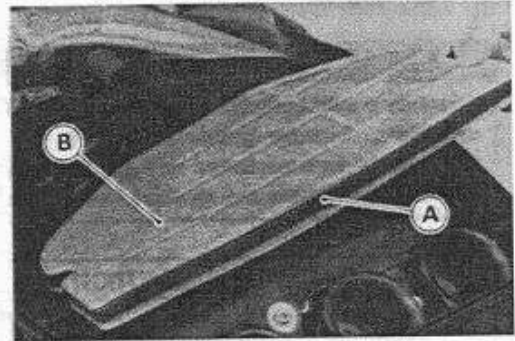

### Element Cleaning and Inspection

#### ⚠ WARNING

Clean the element in a well-ventilated area, and make sure that there are no sparks or flame anywhere near the working area. Because of the danger of highly flammable liquids, do not use gasoline or a low flash-point solvent to clean the element.

- Remove the air cleaner element [A] (see Element Removal).
- Clean the element in a bath of high flash-point solvent, and then dry it with compressed air or by shaking it.
- After cleaning, saturate a clean, lint-free towel with SE, SF, or SG class SAE 30 oil and apply the oil to the element by tapping the element outside with the towel.
- Visually check the element for tears or breaks.
- ★ If the element has any tears or breaks, replace the element.

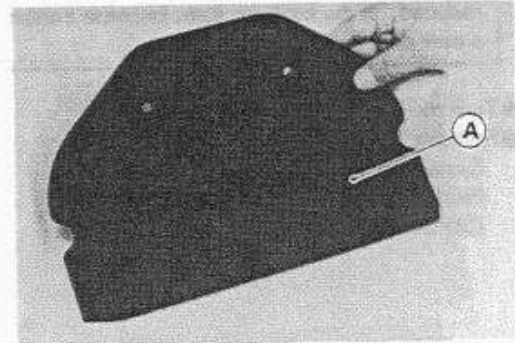

### Oil Draining

A drain hoses [A] is connected to the bottom of the air cleaner housing, to drain water or oil accumulated in the housing.

- Visually check the drain hose if the water or oil accumulates in the hose.
- ★ If any water or oil accumulates in the hose, drain it by taking off the drain plug [B] at the lower end of the drain hoses.

#### ⚠ WARNING

Be sure to reinstall the plug in the drain hose after draining. Oil on tires will make them slippery and can cause an accident and injury.

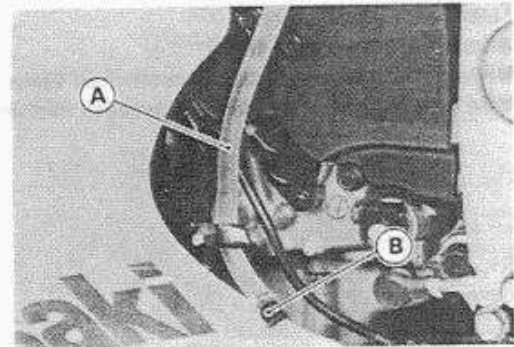

## Fuel Tank

*Fuel Tank Removal***⚠WARNING**

Gasoline is extremely flammable and can be explosive under certain conditions. Turn the ignition switch OFF. Do not smoke. Make sure the area is well-ventilated and free from any source of flame or sparks; this includes any appliance with a pilot light.

**CAUTION**

For California model, if gasoline, solvent, water or any other liquid enters the canister, the canister's vapor absorbing capacity is greatly reduced. If the canister does become contaminated, replace it with a new one.

- Turn the fuel tap to the OFF position.
- Remove:
  - Seats (see Frame chapter)
  - Front Screws [A] of the Side Cover
  - Clamps [B]

Bracket Bolts [A]  
 Mounting Bolts [B]  
 Fuel Hose  
 Evaporative Emission Hoses (California model)

- Remove the fuel tank with the bracket.

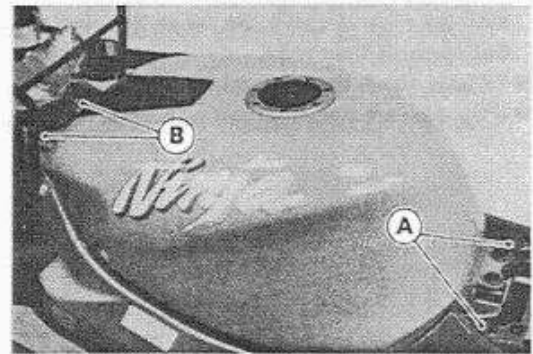
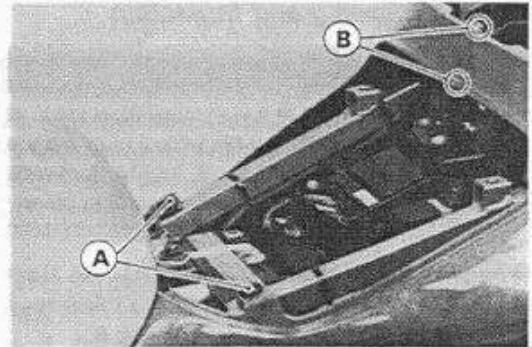
*Fuel Tank Installation*

- Read the above WARNING.
- Route the hoses and leads correctly (see General Information chapter).
- Be sure the hoses are clamped securely to prevent leaks.

*Fuel Tank Inspection*

- Remove the hose(s) from the fuel tank, and open the tank cap.
- Check to see if the breather pipe (also the fuel return pipe for the California model) in the tank is not clogged. Check the tank cap breather also.
- ★ If they are clogged, remove the tank and drain it, and then blow the breather free with compressed air.



**CAUTION**

Do not apply compressed air to the air vent holes [A] in the tank cap. This could cause damage and clogging of the labyrinth in the cap.

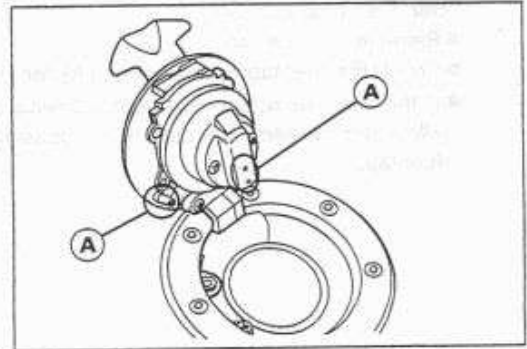
*Fuel Tank Cleaning***▲WARNING**

Clean the tank in a well-ventilated area, and take care that there are no sparks or flame anywhere near the working area. Because of the danger of highly flammable liquids, do not use gasoline or low flash-point solvents to clean the tank.

- Remove the fuel tank and drain it.
- Pour some high flash-point solvent into the fuel tank and shake the tank to remove dirt and fuel deposits.
- Pour the solvent out of the tank.
- Remove the fuel tap from the tank (see Fuel Tap Removal).
- Clean the fuel tap filter screens in a high flash-point solvent.
- Pour high flash-point solvent through the tap in all lever positions.
- Dry the tank and tap with compressed air.
- Install the tap in the tank.
- Install the fuel tank.

*Fuel Tap Removal*

- Remove the fuel tank and drain it.
- Remove the screw and knob [A].
- Remove the mounting bolts [B] with nylon flat washers and take out the fuel tap [C].

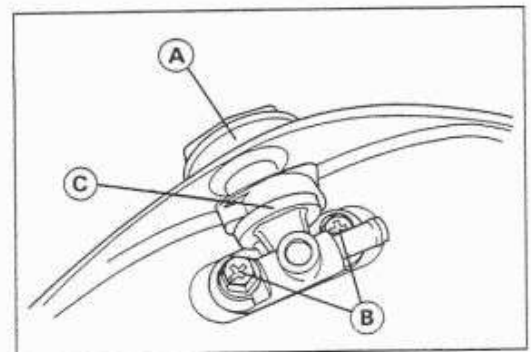
*Fuel Tap Installation*

- Be sure the O-ring is in good condition to prevent leaks.
- Be sure to clamp the fuel hoses to the tap to prevent leaks.
- Be sure the nylon washers are in good condition to prevent leaks.
- Do not use steel washers in place of the nylon washers, because they will not seal the bolts properly and fuel will leak.

### Fuel Tap Inspection

- Remove the fuel tap.
- Check the fuel tap filter screens [A] for any breaks or deterioration.
- ★ If the fuel tap screens have any breaks or are deteriorated, they may allow dirt to reach the carburetor, causing poor running. Replace the fuel tap.

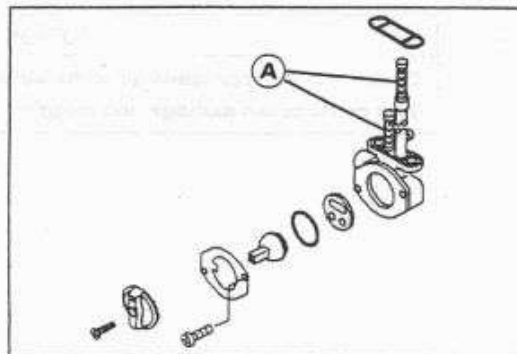

## Fuel Pump, Fuel Filter

### Fuel Pump Removal

#### ⚠ WARNING

Gasoline is extremely flammable and can be explosive under certain conditions. Turn the ignition switch OFF. Do not smoke. Make sure the area is well-ventilated and free from any source of flame or sparks; this includes any appliance with a pilot light.

- Remove:
  - Seats (see Frame chapter)
  - Fuel Tank (see Fuel Tank Removal)
  - Fuel Pump Lead Connector [A]
  - Rear Brake Light Switch Lead Connector [B]
  - Right Footpeg Bracket Mounting Bolts [C]

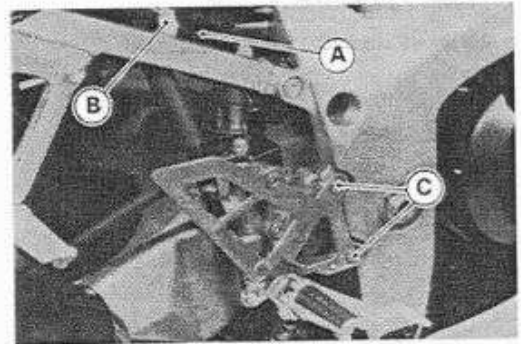

- Remove the fuel pump hoses [A] from the fuel pump.
- Remove the fuel pump [B] toward the rear.

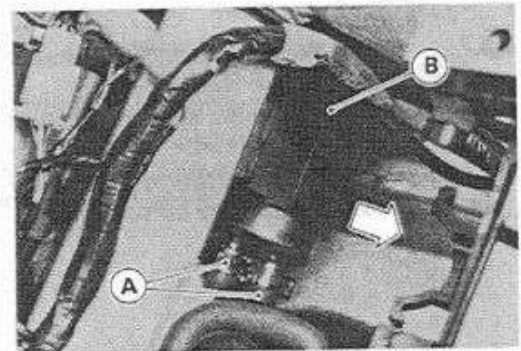

### Fuel Pump Installation

- Connect the fuel filter hose to the front pipe [A].
- Connect the carburetor hose to the rear pipe [B].

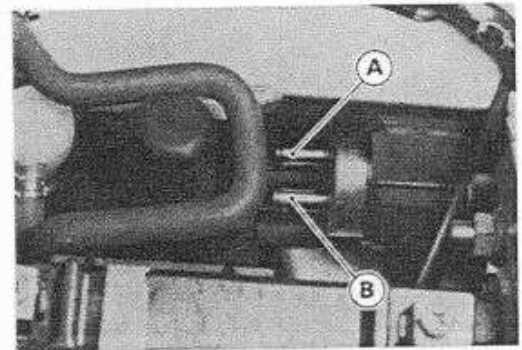

### Fuel Filter Removal

- Remove:
  - Seats (see Frame chapter)
  - Fuel Tank (see Fuel Tank Removal)
- Remove the fuel filter hose [A] from the front pipe of the fuel pump.
- Remove the bracket bolt [B] and then take off the fuel filter [C] with the bracket and hoses.

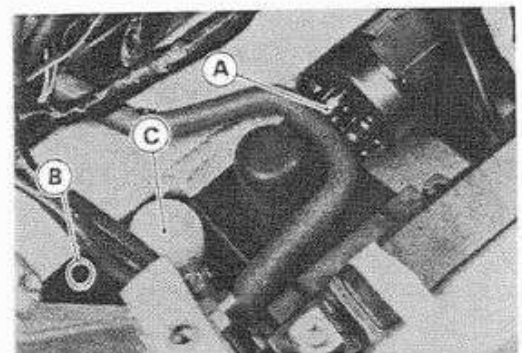

### *Fuel Filter Installation*

- Install the fuel filter [A] and hoses [B] on the bracket [C] as shown.

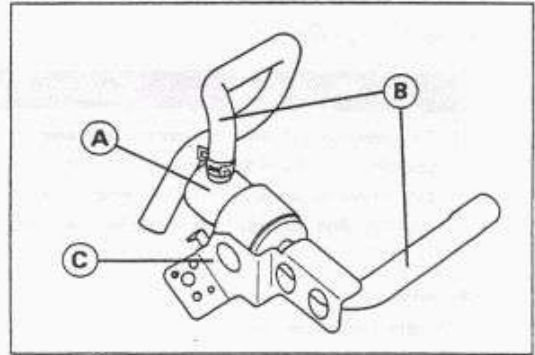

### *Fuel Pump Inspection*

Refer to Electrical System chapter.

### *Fuel Filter Inspection*

- Remove the fuel filter (see Fuel Filter Removal).
- Visually inspect the fuel filter.
- ★ If the filter is clear with no signs of dirt or other contamination, it is OK and need not be replaced.
- ★ If the filter is dark or looks dirty, replace with a new one. Also, check the rest of the fuel system for contamination.

## Vacuum Valve

### Vacuum Valve Inspection

- Remove:
  - Seats (see Frame chapter)
  - Air Cleaner Housing (see Air Cleaner Housing Removal)
  - Vacuum Valve Hoses
- Remove the vacuum valve [A] from the rubber damper [B].

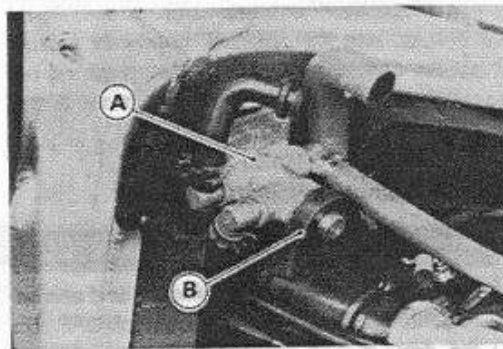

- Remove the drain screw [A] from the bottom of the chamber [B].
- ★ If any liquid accumulates in the chamber, drain it.

**⚠ WARNING**

**The liquid may contain gasoline.**

- Replace the O-ring [C] with a new one.
  - After draining, install the drain screw with the O-ring.
- Torque – Vacuum Valve Drain Screw: 1.0 N-m (0.1 kg-m, 9 in-lb)**

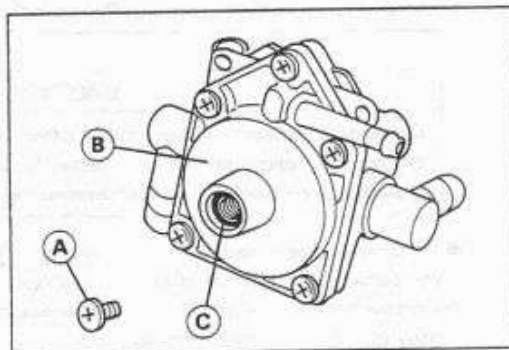

- Using the vacuum gauge and fork oil level gauge, inspect the vacuum valve operation (see Vacuum Switch Valve Test in Engine Top End chapter).

**Special Tool – Vacuum Gauge: 57001-1369**  
**Fork Oil Level Gauge: 57001-1290**

- When applying vacuum (1.5 cmHg) to the vacuum sensing fitting [A], air flows from pipe [B] to pipe [C], and vice versa.
- When stopping applying vacuum, air flows from pipe [B] to pipe [D], and vice versa.
- ★ Nevertheless if the vacuum valve does not operate as described, replace it with a new one.

**CAUTION**

**Do not use compressed air during the valve check, or the vacuum valve may be damaged.**

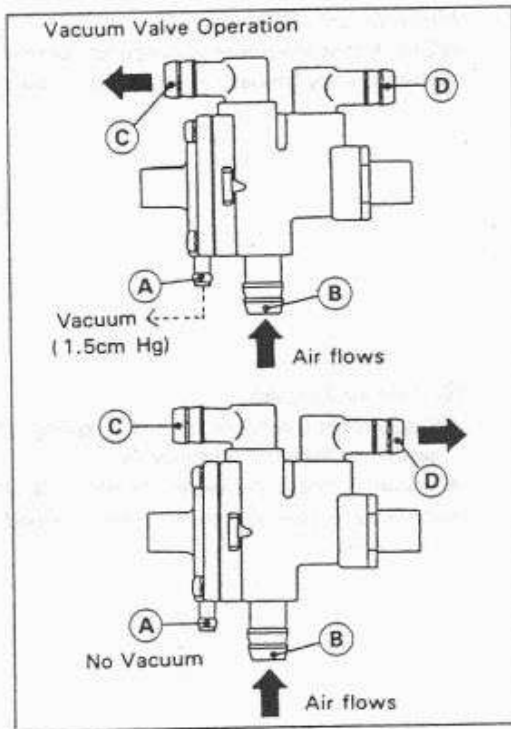

### Evaporative Emission Control System (California Model Only)

The Evaporative Emission Control System routes fuel vapors from the fuel system into the running engine or stores the vapors in a canister when the engine is stopped. Although no adjustments are required, a thorough visual inspection must be made at the intervals specified by the Periodic Maintenance Chart.

#### Parts Removal/Installation

##### **▲WARNING**

Gasoline is extremely flammable and can be explosive under certain conditions. Turn the ignition switch OFF. Do not smoke. Make sure the area is well-ventilated and free from any source of flame or sparks; this includes any appliance with a pilot light.

##### **CAUTION**

If gasoline, solvent, water or any other liquid enters the canister, the canister's vapor absorbing capacity is greatly reduced. If the canister does become contaminated, replace it with a new one.

- To prevent the gasoline from flowing into or out of the canister, hold the separator perpendicular to the ground.
- Connect the hoses according to the diagram of the system. Make sure they do not get pinched or kinked.

#### Hose Inspection

- Check that the hoses are securely connected.
- Replace any kinked, deteriorated or damaged hoses.

#### Separator Inspection

- Disconnect the hoses from the liquid/vapor separator, and remove the separator from the motorcycle.
- Visually inspect the separator for cracks and other damage.
- ★ If the separator has any cracks or is badly damaged, replace it with a new one.

#### Separator Operation Test

##### **▲WARNING**

Gasoline is extremely flammable and can be explosive under certain conditions. Turn the ignition switch OFF. Do not smoke. Make sure the area is well-ventilated and free from any source of flame or sparks; this includes any appliance with a pilot light.

- Connect the hoses to the separator, and install the separator on the motorcycle.

- Disconnect the breather hose from the separator, and inject about 20 mL of gasoline into the separator through the hose fitting.
- Disconnect the fuel return hose from the fuel tank.
- Run the open end of the return hose into the container and hold it level with the tank top.
- Start the engine, and let it idle.
- ★ If the gasoline in the separator comes out of the hose, the separator works well. If it does not, replace the separator with a new one.

### *Canister Inspection*

- Remove the canister, and disconnect the hoses from the canister.
- Visually inspect the canister for cracks and other damage.
- ★ If the canister has any cracks or bad damage, replace it with a new one.

### **NOTE**

- *The canister is designed to work well through the motorcycle's life without any maintenance if it is used under normal conditions.*

... ..  
... ..  
... ..  
... ..  
... ..

... ..  
... ..  
... ..  
... ..



# Cooling System

## Table of Contents

Exploded View .....	3-2
Coolant Flow Chart.....	3-3
Specifications .....	3-4
Coolant .....	3-5
Coolant Level Inspection .....	3-5
Coolant Draining.....	3-5
Coolant Filling.....	3-6
Pressure Testing.....	3-7
Water Pump.....	3-8
Water Pump Removal.....	3-8
Water Pump Installation .....	3-8
Water Pump Inspection .....	3-8
Radiator, Radiator Fan .....	3-9
Radiator, Radiator Fan Removal.....	3-9
Radiator Inspection.....	3-10
Radiator Cap Inspection .....	3-10
Thermostat.....	3-12
Thermostat Removal.....	3-12
Thermostat Installation .....	3-12
Thermostat Inspection .....	3-12
Radiator Fan Switch, Water Temperature Sensor.....	3-14
Radiator Fan Switch, Water Temperature Sensor Removal .....	3-14
Radiator Fan Switch, Water Temperature Sensor Installation.....	3-14
Radiator Fan Switch, Water Temperature Sensor Inspection .....	3-14

### 3-2 COOLING SYSTEM

#### Exploded View

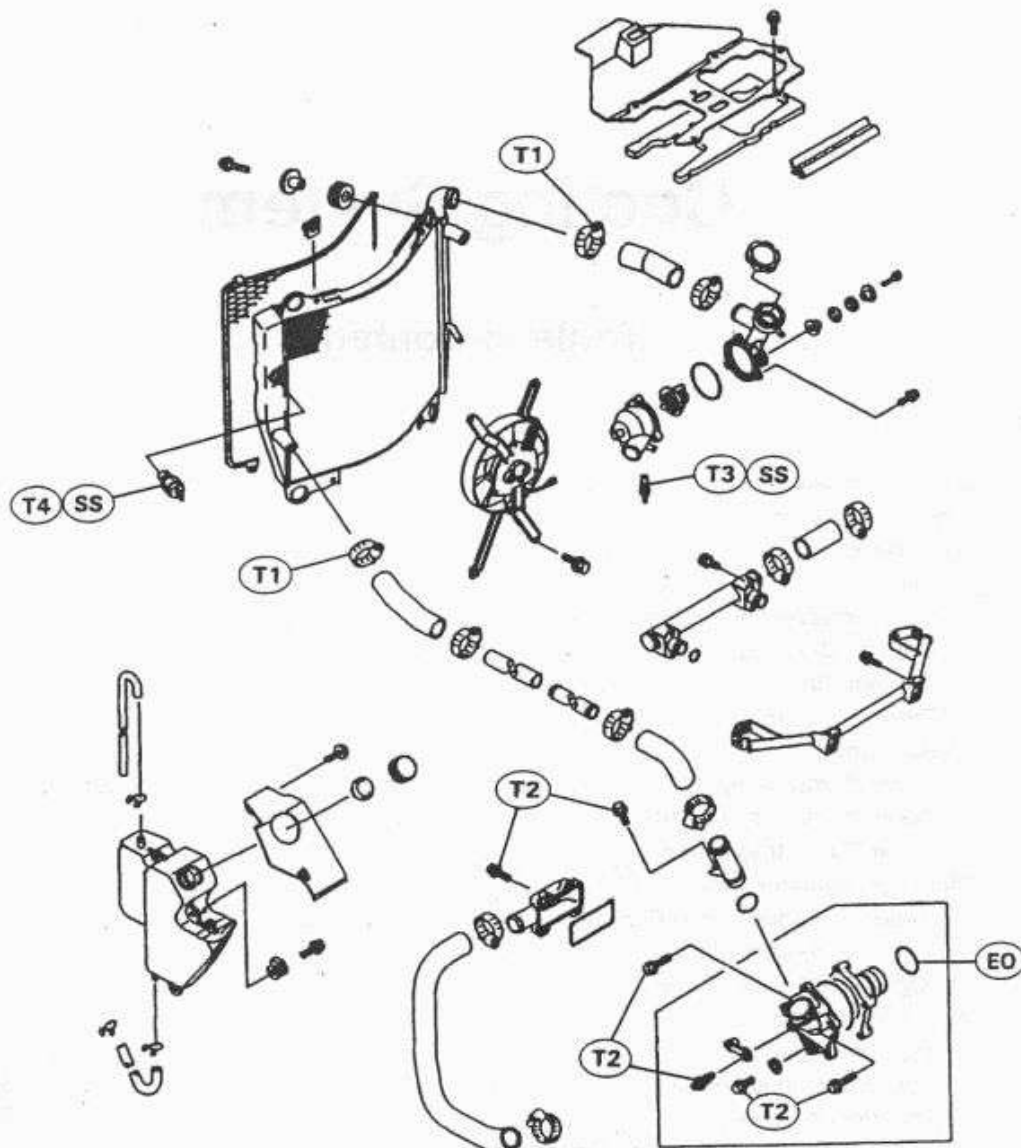

ZX750-P:

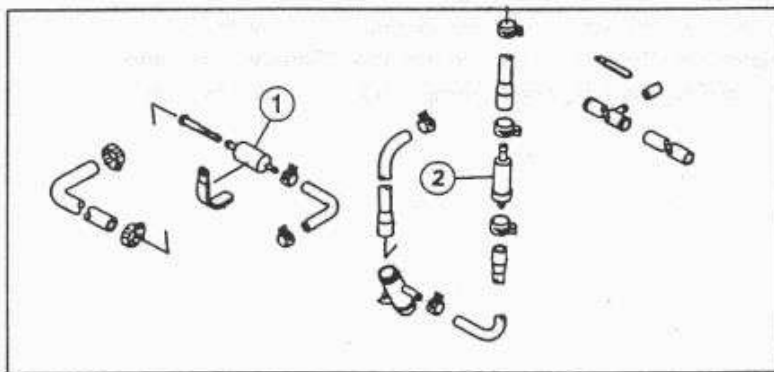

(AR, FG, FR, IT, KR, NL, ST, UK Models)

EO: Apply engine oil.  
SS: Apply silicone sealant.

T1: 2.5 N-m (0.25 kg-m, 22 in-lb)  
T2: 9.8 N-m (1.0 kg-m, 87 in-lb)  
T3: 15 N-m (1.5 kg-m, 11.0 ft-lb)  
T4: 18 N-m (1.8 kg-m, 13.0 ft-lb)

AR: Austria  
FG: Germany  
FR: France  
IT: Italy  
KR: Korea  
NL: Netherland  
ST: Switzerland  
UK: U.K.

1. Coolant Filter  
2. Valve Assy

## Coolant Flow Chart

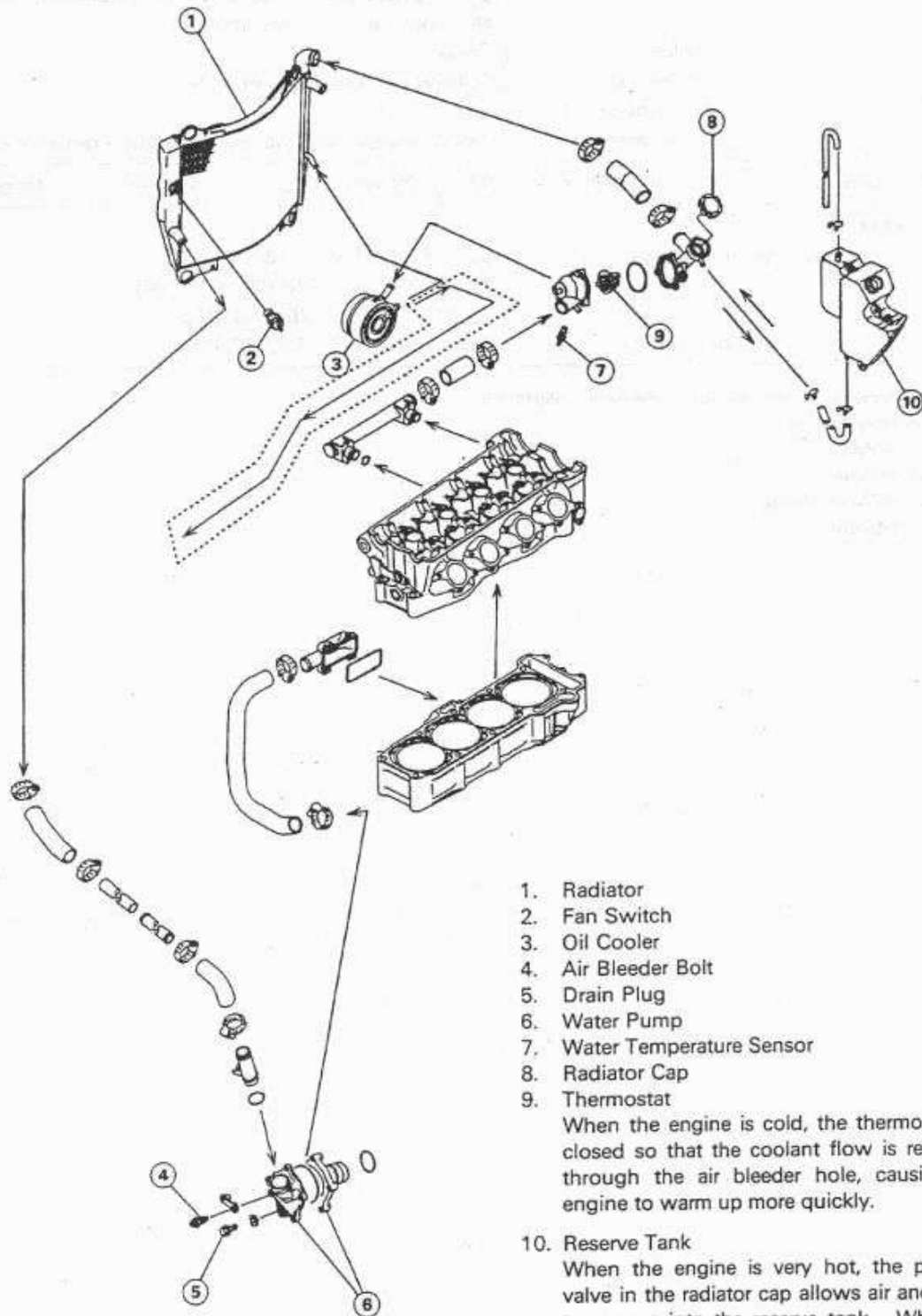

1. Radiator
2. Fan Switch
3. Oil Cooler
4. Air Bleeder Bolt
5. Drain Plug
6. Water Pump
7. Water Temperature Sensor
8. Radiator Cap
9. Thermostat

When the engine is cold, the thermostat is closed so that the coolant flow is restricted through the air bleeder hole, causing the engine to warm up more quickly.

10. Reserve Tank

When the engine is very hot, the pressure valve in the radiator cap allows air and vapor to escape into the reserve tank. When the engine cools down, the pressure drop draws the vacuum valve (another small valve) open, admitting coolant from the reserve tank into the radiator.

### 3-4 COOLING SYSTEM

#### Specifications

Item	Standard
<b>Coolant provided when shipping:</b> Type  Color Mixed ratio Freezing point Total amount	Permanent type antifreeze (soft water and ethylene glycol plus corrosion and rust inhibitor chemicals for aluminum engines and radiators) Green Soft water 50%, coolant 50% -35°C (-31°F) 2.6L (reserve tank full level including radiator and engine)
<b>Radiator cap</b> Relief pressure:	93 ~ 123 kPa (0.95 ~ 1.25 kg/cm <sup>2</sup> , 14 ~ 18 psi)
<b>Thermostat:</b> Valve opening temperature  Valve full opening lift	58 ~ 62°C (136 ~ 144 °F) ZX750P2: (FG)(FR)(IT)(ST)(UK) 80 ~ 84°C (176 ~ 183°F) 8mm or more @95°C (203 °F)

**Sealant – Kawasaki Bond (Silicone Sealant): 56019-120**

- (FG): Germany Model
- (FR): France Model
- (IT): Italy Model
- (ST): Switzerland Model
- (UK): U.K. Model

## Coolant

## Coolant Level Inspection

## NOTE

- Check the level when the engine is cold (room or ambient temperature).
- Check the coolant level in the reserve tank with the motorcycle held perpendicular.
- ★ If the coolant level is lower than the "L" (Low) level line [A], add coolant to the "F" (Full) level line [B].

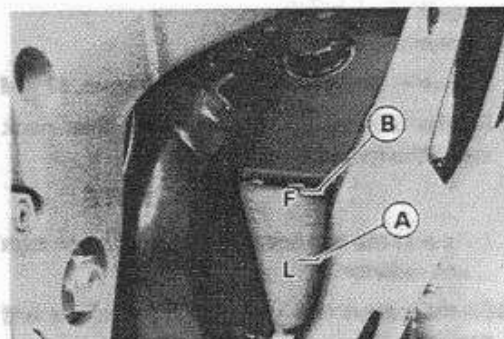

## CAUTION

For refilling, add the specified mixture of coolant and soft water. Adding water alone dilutes the coolant and degrades its anticorrosion properties. The diluted coolant can attack the aluminum engine parts. In an emergency, soft water alone can be added. But the diluted coolant must be returned to the correct mixture ratio within a few days.

If coolant must be added often, or the reservoir tank has run completely dry; there is probably leakage in the cooling system. Check the system for leaks.

## Coolant Draining

## ⚠WARNING

To avoid burns, do not remove the radiator cap or try to change the coolant when the engine is still hot. Wait until it cools down. Coolant on tires will make them slippery and can cause an accident and injury. Immediately wipe up or wash away any coolant that spills on the frame, engine, or other painted parts. Since coolant is harmful to the human body, do not use for drinking.

- Remove:
    - Right Inner Fairing and Lower Fairings (see Frame chapter)
    - Radiator Cap
  - Place a container under the drain plug [A] at the bottom of the water pump [B].
  - Drain the coolant from the radiator and engine by removing the drain plug.
- 
- Remove:
    - Mounting Bolts [A]
    - Reserve Tank [B]
  - Remove the cap [C] and pour the coolant into a container.

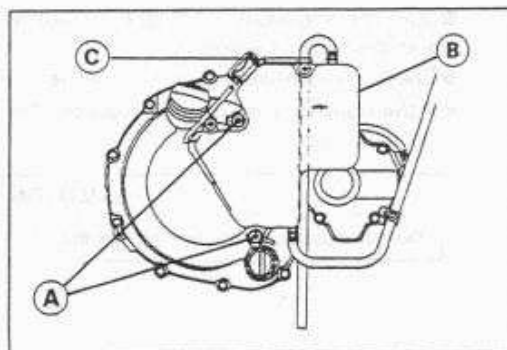
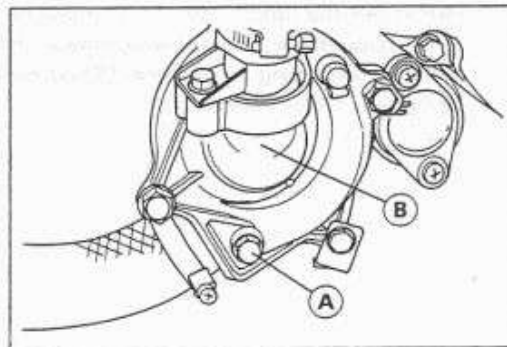

#### Coolant Filling

- Tighten the drain plug.
- Torque – Drain Plug: 9.8 N-m (1.0 kg-m, 87 in-lb)**
- Fill the radiator up to the radiator filler neck [A] with coolant, and install the radiator cap.

#### NOTE

- Pour in the coolant slowly so that it can expel the air from the engine and radiator.
- Fill the reserve tank up to the "F" level line with coolant, and install the cap.

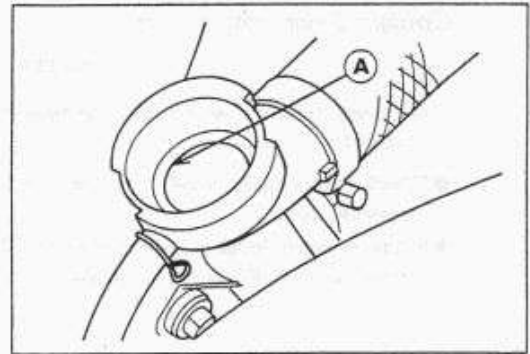

#### CAUTION

Soft or distilled water must be used with the antifreeze (see below for antifreeze) in the cooling system.  
 If hard water is used in the system, it causes scales accumulation in the water passages, and considerably reduces the efficiency of the cooling system.

#### Water and Coolant Mixture Ratio (Recommended)

Soft Water	:	50%
Coolant	:	50%
Freezing Point	:	-35°C (-31°F)
Total Amount	:	2.6 L

#### NOTE

- Choose a suitable mixture ratio by referring to the coolant manufacturer's directions.

- Remove the rubber cap [A], and loosen the air bleeder bolt [B], until the coolant begins to flow out the air bleeder bolt hole (that is, when all the remaining air has been forced out).
- Tighten the air bleeder bolt.

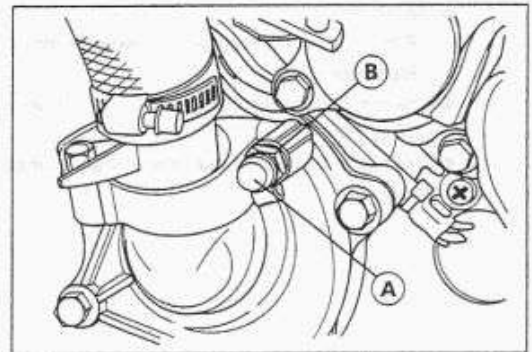

- Start the engine, warm it up thoroughly until the radiator fan turns on and then stop the engine.
- Check the coolant level in the reserve tank after the engine cools down.
- ★ If the coolant level is lower than the "L" level line, add coolant to the "F" level line.

#### CAUTION

Do not add more coolant above the "F" level line.

**Pressure Testing**

- Remove the inner fairing (see Frame chapter).
- Remove the radiator cap, and install a cooling system pressure tester [A] on the filler neck.

**NOTE**

- Wet the cap sealing surfaces with water or coolant to prevent pressure leaks.
- Build up pressure in the system carefully until the pressure reaches 123 kPa (1.25 kg/cm<sup>2</sup>, 18 psi).

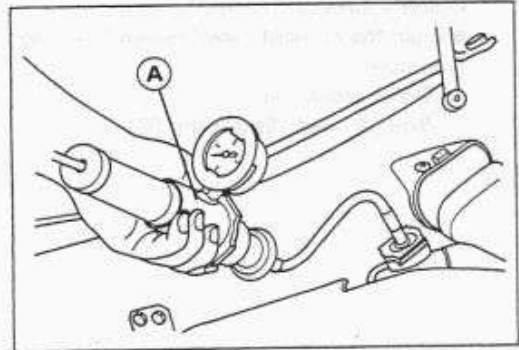
**CAUTION**

During pressure testing, do not exceed the pressure for which the system is designed. The maximum pressure is 123 kPa (1.25 kg/cm<sup>2</sup>, 18 psi).

- Watch the gauge for at least 6 seconds.
- ★ If the pressure holds steady, the system is all right.
- ★ If the pressure drops soon, check for leaks.

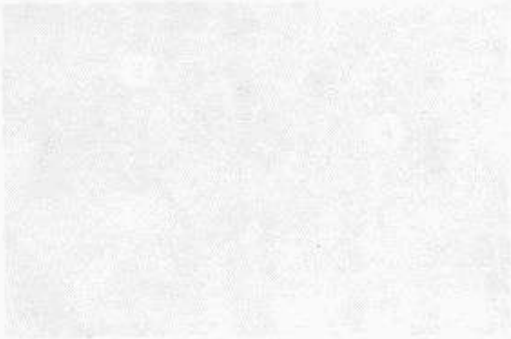

## Water Pump

### Water Pump Removal

- Drain the coolant (see Coolant Draining).
- Remove:
  - Water Hose [A]
  - Bolt [B] and Water Pipe [C]

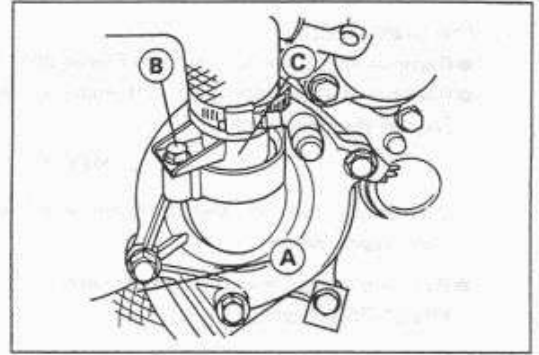

Bolts [D] and Water Pump [E]

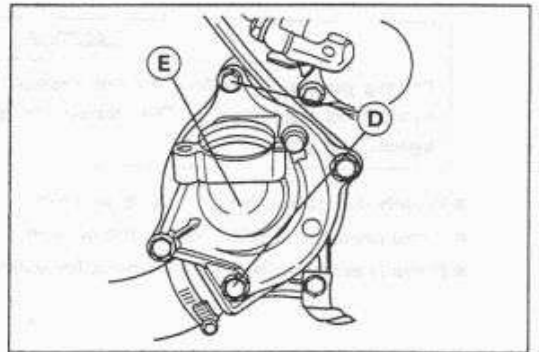

### Water Pump Installation

- Note the position of the oil pump shaft projection [A] and turn the water pump shaft so that the projection fits into the slot [B].

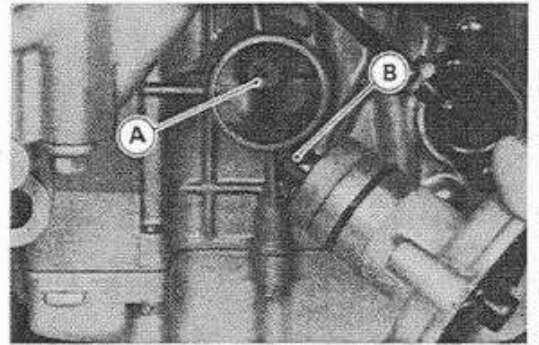

### Water Pump Inspection

- Check the drainage outlet passage [A] at the side of the water pump body for coolant leaks.
- ★ If the mechanical seal is damaged, the coolant leaks through the seal and drains through the passage. Replace the water pump unit with a new one.

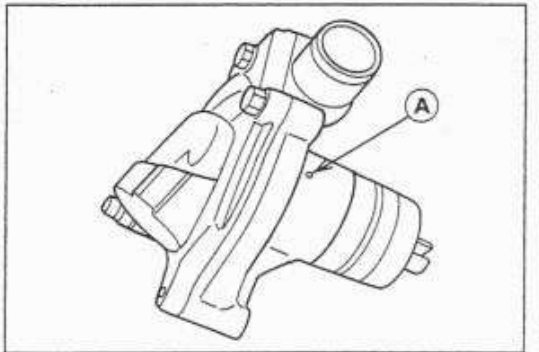

- Visually inspect the impeller [A].
- ★ If the surface is corroded, or if the blades are damaged, replace the water pump unit with a new one.

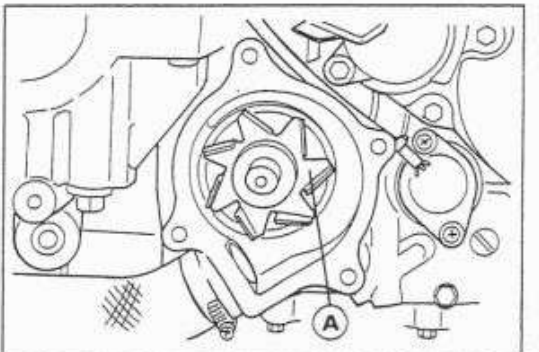



## Radiator, Radiator Fan

### Radiator, Radiator Fan Removal

#### ⚠ WARNING

The radiator fan is connected directly to the battery. The radiator fan may start even if the ignition switch is off. NEVER TOUCH THE RADIATOR FAN UNTIL THE RADIATOR FAN CONNECTOR IS DISCONNECTED. TOUCHING THE FAN BEFORE THE CONNECTOR IS DISCONNECTED COULD CAUSE INJURY FROM THE FAN BLADES.

#### ● Remove:

- Fuel Tank (see Fuel System chapter)
- Upper and Lower Fairings (see Frame chapter)
- Coolant (see Coolant Draining)
- Radiator Fan Connector [A]

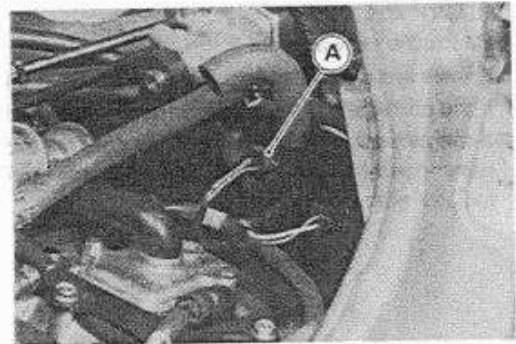

Radiator Hoses [A]

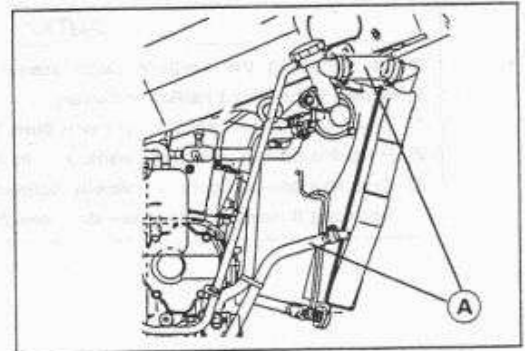

Fan Switch Leads [A]  
Radiator Hose [B]

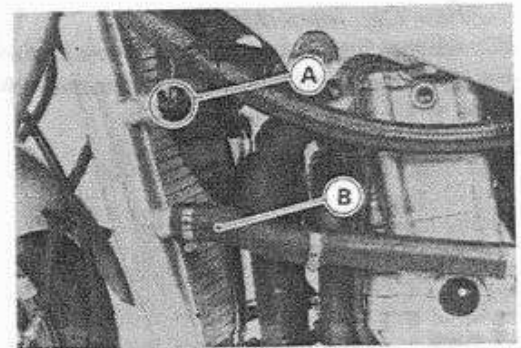

Radiator Mounting Bolts [A]  
Radiator

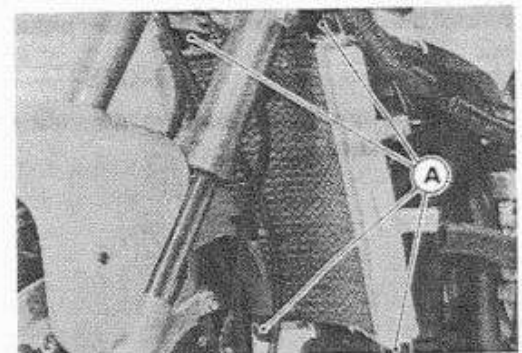

Radiator Fan Mounting Bolts [A]  
Radiator Fan [B]

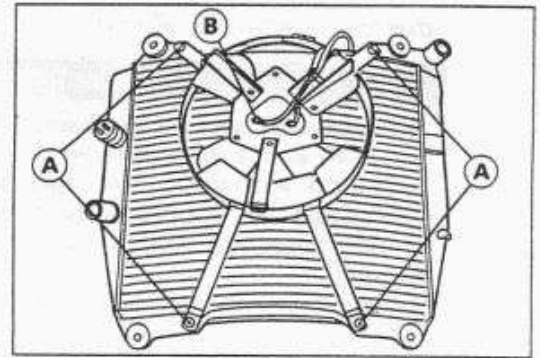

#### Radiator Inspection

- Check the radiator core.
- ★ If there are obstructions to air flow, remove them.
- ★ If the corrugated fins are deformed, carefully straighten them.
- ★ If the air passages of the radiator core are blocked more than 20% by unremovable obstructions or irreparably deformed fins, replace the radiator with a new one.

#### CAUTION

When cleaning the radiator with steam cleaner, be careful of the following to prevent radiator damage.

- 1) Keep the steam gun away more than 0.5 m from the radiator core.
- 2) Hold the steam gun perpendicular to the core surface.
- 3) Run the steam gun vertically following the core fin direction. Running it horizontally may damage the fin.

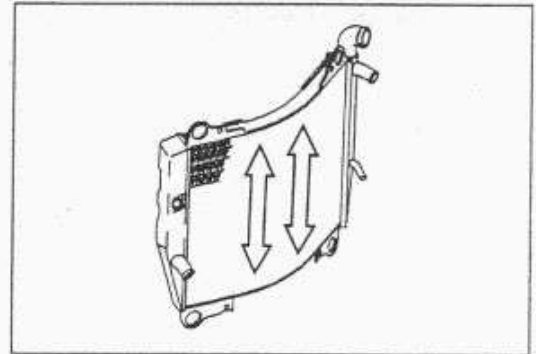

#### Radiator Cap Inspection

- Check the condition of the top [A] and bottom [B] valve seals.
- ★ If any one of them shows visible damage, replace the cap with a new one.

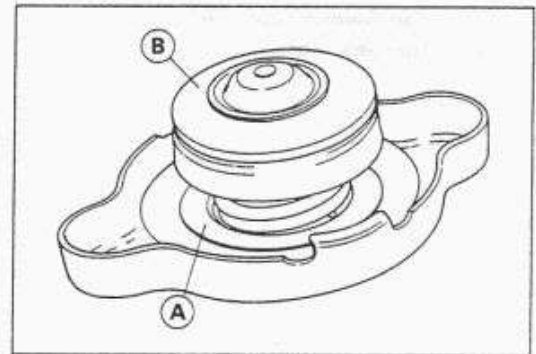

- Install the cap [A] on a cooling system pressure tester [B].

#### NOTE

- Wet the cap sealing surfaces with water or coolant to prevent pressure leaks.

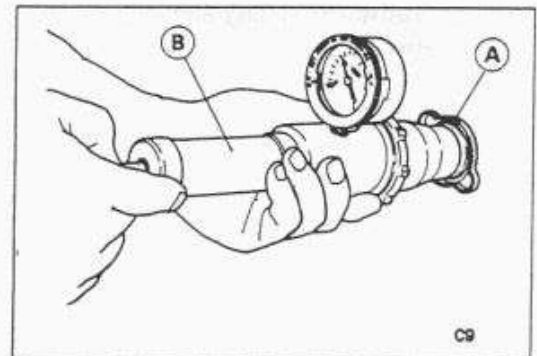

● Watching the pressure gauge, pump the pressure tester to build up the pressure until the relief valve opens: the gauge hand flicks downward. Stop pumping at once. The relief valve must open within the specified range in the table below and the gauge hand must remain within the same range at least 6 seconds.

**Radiator Cap Relief Pressure**

**Standard:** 93 ~ 123 kPa (0.95 ~ 1.25 kg/cm<sup>2</sup>, 14 ~ 18 psi)

★ If the cap cannot hold the specified pressure, or if it holds too much pressure, replace it with a new one.

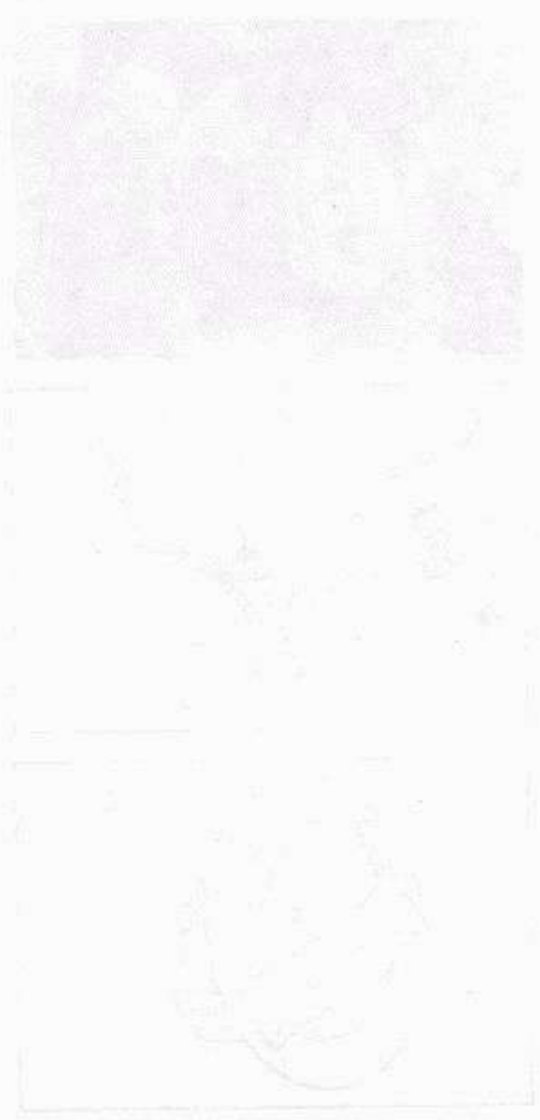

## Thermostat

### Thermostat Removal

- Remove:
  - Coolant (see Coolant Draining)
  - Bolts [A] and Thermostat Housing Cover [B]
  - Thermostat

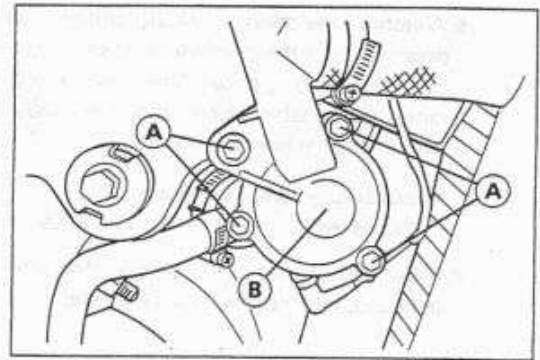

### Thermostat Installation

- Install the thermostat in the thermostat housing so that the air bleeder hole [A] is on top as shown.

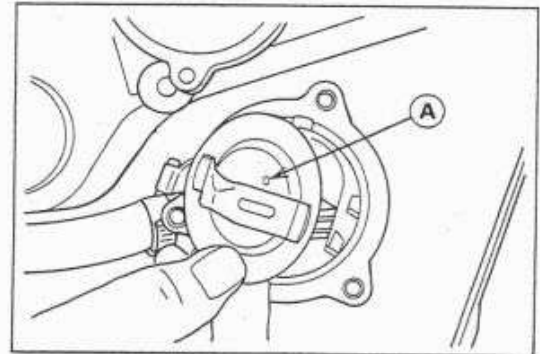

- Be sure to install the O-ring [A] on the housing cover.

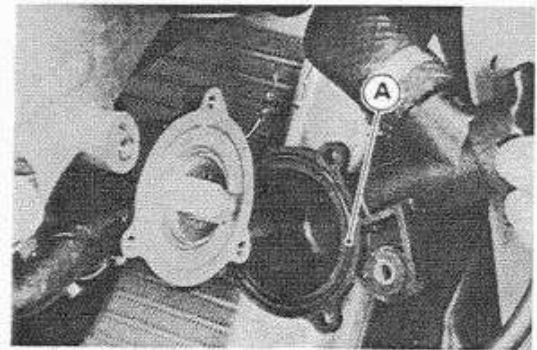

- Be sure to attach the ground lead [A] to the cover bolt [B].
- Fill the radiator with coolant.

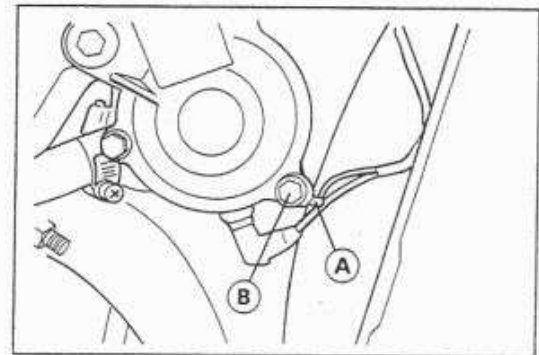

### Thermostat Inspection

- Remove the thermostat, and inspect the thermostat valve [A] at room temperature.
- ★ If the valve is open, replace the thermostat with a new one.

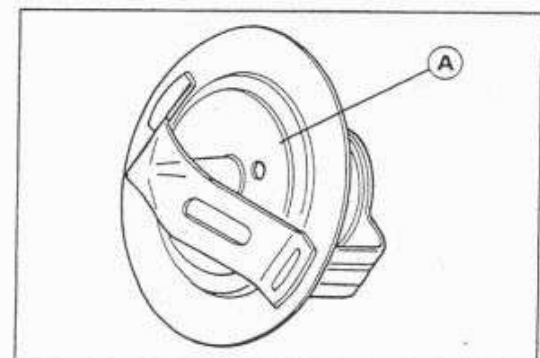

- To check valve opening temperature, suspend the thermostat [A] in a container of water and raise the temperature of the water.  
[B] Thermometer

★ If the measurement is out of the specified range, replace the thermostat with a new one.

**Thermostat Valve Opening Temperature**

58 ~ 62°C (136 ~ 144°F)

ZX750P2: (FG)(FR)(IT)(ST)(UK)

80 ~ 84°C (176 ~ 183°F)

- (FG): Germany Model
- (FR): France Model
- (IT): Italy Model
- (ST): Switzerland Model
- (UK): U.K. Model

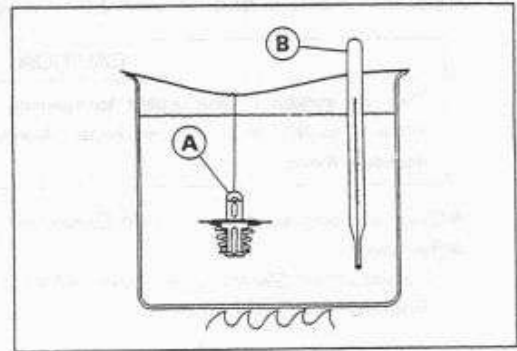

## Radiator Fan Switch, Water Temperature Sensor

### Radiator Fan Switch, Water Temperature Sensor Removal

#### CAUTION

The fan switch or the water temperature sensor should never be allowed to fall on a hard surface. Such a shock to their parts can damage them.

- Drain the coolant (see Coolant Draining).
- Remove:
  - Radiator Fan Switch Lead Connectors [A]
  - Radiator Fan Switch [B]
  
- Water Temperature Sensor Lead Connector [A]
- Water Temperature Sensor [B]

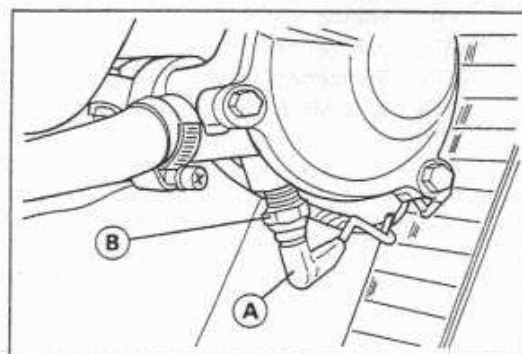
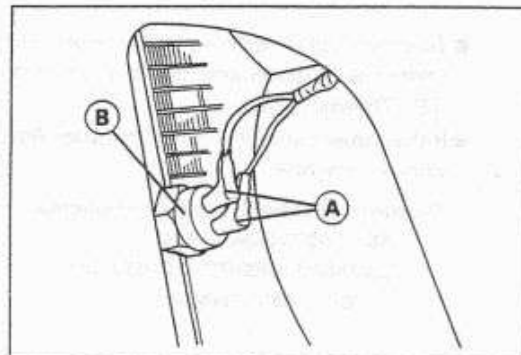

### Radiator Fan Switch, Water Temperature Sensor Installation

- Apply silicone sealant to the threads of the fan switch and water temperature sensor.

Sealant – Kawasaki Bond (Silicone Sealant): 56019-120

- Tighten the fan switch and water temperature sensor.

Torque – Radiator Fan Switch : 18 N-m (1.8 kg-m, 13.0 ft-lb)

Water Temperature Sensor : 15 N-m (1.5 kg-m, 11.0 ft-lb)

### Radiator Fan Switch, Water Temperature Sensor Inspection

- Refer to Electrical System chapter for these inspection.

# Engine Top End

## Table of Contents

4

Exploded View .....	4-2	Valve Clearance Adjustment .....	4-17
Specifications .....	4-4	Valve Removal .....	4-20
Clean Air System .....	4-6	Valve Installation .....	4-20
Air Suction Valve Inspection .....	4-6	Valve Guide Removal .....	4-20
Vacuum Switch Valve Removal .....	4-6	Valve Guide Installation .....	4-20
Vacuum Switch Valve Installation .....	4-6	Valve-to-Guide Clearance Measurement (Wobble Method) .....	4-20
Vacuum Switch Valve Test.....	4-6	Valve Seat Inspection .....	4-21
Clean Air System Hose Inspection.....	4-7	Valve Seat Repair.....	4-21
Cylinder Head Cover .....	4-8	Seat Cutter Operation Care .....	4-22
Cylinder Head Cover Removal.....	4-8	Marks Stamped on the Cutter .....	4-22
Cylinder Head Cover Installation .....	4-8	Operating Procedures .....	4-22
Camshaft Chain Tensioner.....	4-10	Cylinder, Pistons .....	4-25
Camshaft Chain Tensioner Removal.....	4-10	Cylinder Removal .....	4-25
Camshaft Chain Tensioner Installation .....	4-10	Cylinder Installation.....	4-25
Camshaft, Camshaft Chain .....	4-11	Piston Removal.....	4-25
Camshaft Removal .....	4-11	Piston Installation .....	4-26
Camshaft Installation.....	4-11	Cylinder Wear .....	4-26
Camshaft, Camshaft Cap Wear .....	4-13	Piston Wear .....	4-27
Camshaft Chain Removal.....	4-13	Piston Ring, Piston Ring Groove Wear .....	4-27
Camshaft Chain Wear.....	4-13	Piston Ring End Gap.....	4-27
Cylinder Head.....	4-14	Carburetor Holder.....	4-28
Cylinder Compression Measurement.....	4-14	Carburetor Holder Installation .....	4-28
Cylinder Head Removal.....	4-14	Muffler .....	4-29
Cylinder Head Installation .....	4-15	Muffler Removal .....	4-29
Valves .....	4-17	Muffler Installation .....	4-29
Valve Clearance Inspection .....	4-17		

Exploded View

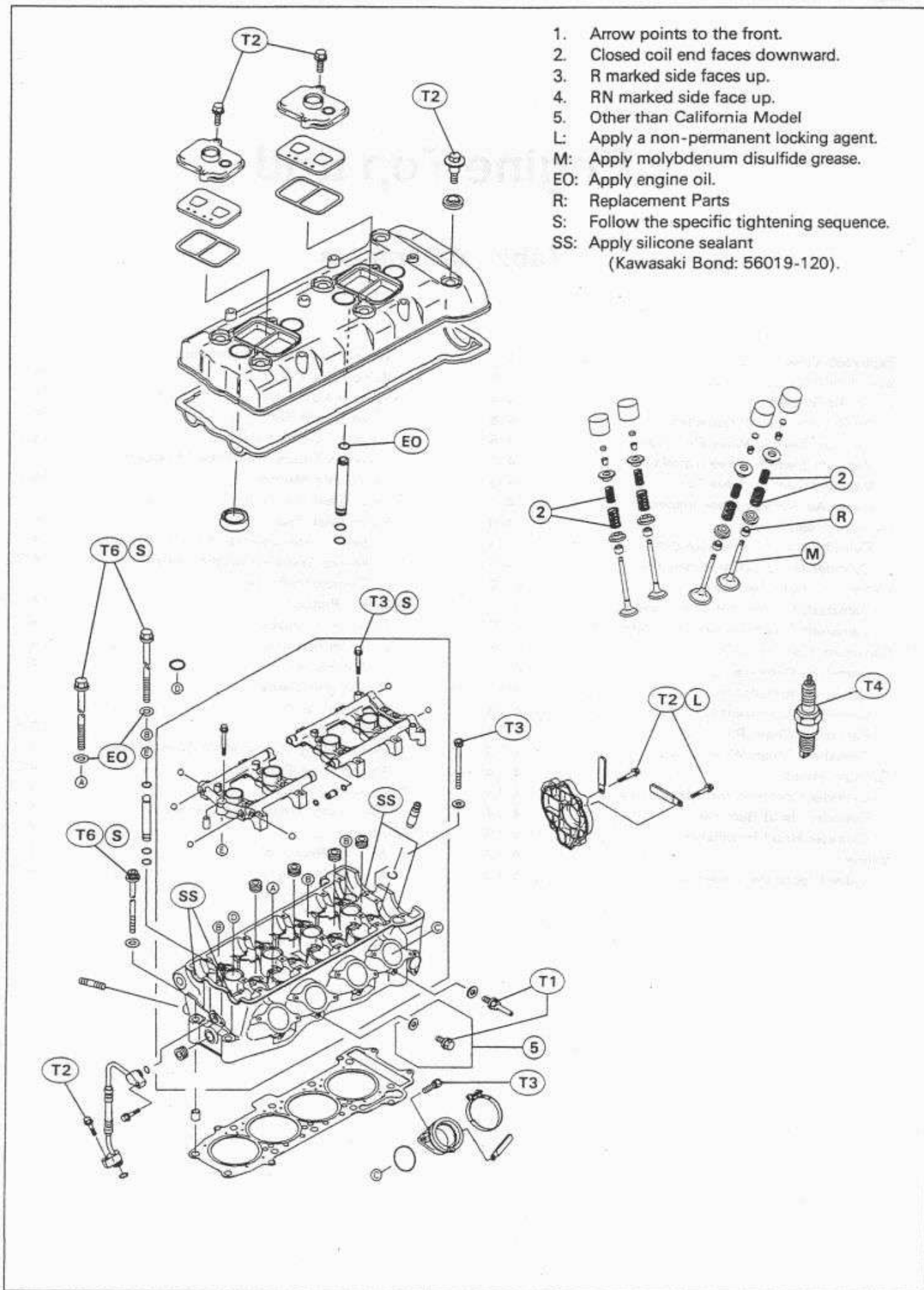

1. Arrow points to the front.
2. Closed coil end faces downward.
3. R marked side faces up.
4. RN marked side face up.
5. Other than California Model
- L: Apply a non-permanent locking agent.
- M: Apply molybdenum disulfide grease.
- EO: Apply engine oil.
- R: Replacement Parts
- S: Follow the specific tightening sequence.
- SS: Apply silicone sealant  
(Kawasaki Bond: 56019-120).



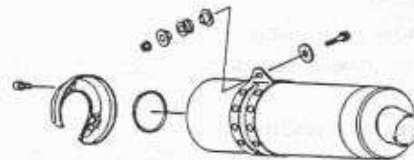
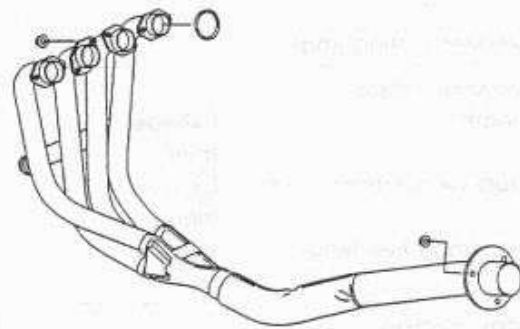
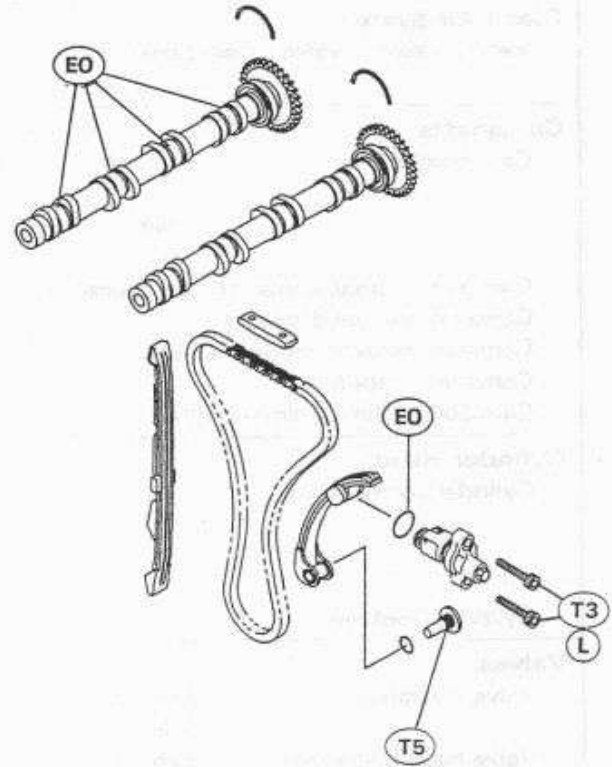
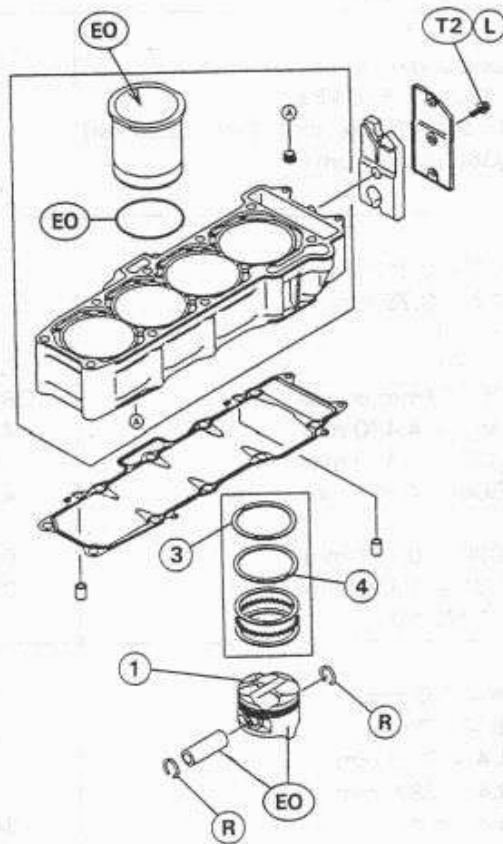

- T1: 4.9 N-m (0.50 kg-m, 43 in-lb)
- T2: 9.8 N-m (1.0 kg-m, 87 in-lb)
- T3: 12 N-m (1.2 kg-m, 104 in-lb)
- T4: 13 N-m (1.3 kg-m, 113 in-lb)
- T5: 25 N-m (2.5 kg-m, 18.0 ft-lb)
- T6: 44 N-m (4.5 kg-m, 33 ft-lb)

## 4-4 ENGINE TOP END

### Specifications

Item	Standard	Service Limit
<b>Clean Air System:</b> Vacuum switch valve closing pressure:	Open → Close 57 ~ 65 kPa (430 ~ 490 mmHg)	---
<b>Camshafts:</b> Cam height: Exhaust Inlet Camshaft journal, camshaft cap clearance Camshaft journal diameter Camshaft bearing inside diameter Camshaft runout Camshaft chain 20-link length	35.446 ~ 35.554 mm, 35.046 ~ 35.154 mm (FR) 37.246 ~ 37.354 mm, 35.046 ~ 35.154 mm (FR) 0.048 ~ 0.091 mm 23.930 ~ 23.952 mm 24.000 ~ 24.021 mm TIR 0.02 mm or less 155.5 ~ 155.8 mm	35.35 mm 34.95 mm 37.15 mm 34.95 mm 0.18 mm 23.90 mm 24.08 mm TIR 0.1 mm 157.8 mm
<b>Cylinder Head:</b> Cylinder compression Cylinder head warp	(usable range) 1 030 ~ 1 570 kPa (10.5 ~ 16.0 kg/cm <sup>2</sup> , 149 ~ 228 psi) @360 r/min (rpm) ---	--- 0.05 mm
<b>Valves:</b> Valve clearance: Exhaust Inlet Valve head thickness: Exhaust Inlet Valve stem bend Valve stem diameter: Exhaust Inlet Valve guide inside diameter Valve/valve guide clearance (wobble method): Exhaust Inlet Valve seat cutting angle	0.22 ~ 0.31 mm 0.17 ~ 0.25 mm 0.8 mm 0.5 mm TIR 0.01 mm or less 4.455 ~ 4.470 mm 4.475 ~ 4.490 mm 4.500 ~ 4.512 mm 0.090 ~ 0.171 mm 0.031 ~ 0.113 mm 45°, 32°, 60°	--- --- 0.5 mm 0.25 mm TIR 0.05 mm 4.44 mm 4.46 mm 4.58 mm 0.37 mm 0.32 mm ---
Valve seat surface: Width: Exhaust Inlet Outside diameter: Exhaust Inlet Valve spring free length: Inner Outer	0.5 ~ 1.0 mm 0.5 ~ 1.0 mm 24.4 ~ 24.6 mm 28.4 ~ 28.6 mm 36.47 mm 41.39 mm	--- --- --- --- 34.8 mm 39.7 mm
<b>Cylinder, Piston:</b> Cylinder inside diameter Piston diameter Piston/cylinder clearance Piston ring/groove clearance: Top Second Piston ring groove width: Top Second Piston ring thickness: Top Second Piston ring end gap: Top Second	73.000 ~ 73.012 mm 72.942 ~ 72.958 mm 0.042 ~ 0.070 mm 0.05 ~ 0.09 mm 0.03 ~ 0.07 mm 0.84 ~ 0.86 mm 0.82 ~ 0.84 mm 0.77 ~ 0.79 mm 0.77 ~ 0.79 mm 0.20 ~ 0.35 mm 0.40 ~ 0.55 mm	73.1 mm 72.8 mm --- 0.19 mm 0.17 mm 0.94 mm 0.92 mm 0.70 mm 0.70 mm 0.65 mm 0.85 mm

(FR): France Model

**Special Tool – Fork Oil Level Gauge: 57001-1290**  
**Vacuum Gauge: 57001-1369**  
**Compression Gauge: 57001-221**  
**Compression Gauge Adapter, M10 X 1.0: 57001-1317**  
**Valve Spring Compressor Assembly: 57001-241**  
**Valve Spring Compressor Adapter,  $\phi 22$ : 57001-1202**  
**Valve Guide Arbor,  $\phi 4.5$ : 57001-1331**  
**Valve Guide Reamer,  $\phi 4.5$ : 57001-1333**  
**Valve Seat Cutter,  $60^\circ - \phi 30$ : 57001-1123**  
**Valve Seat Cutter,  $45^\circ - \phi 27.5$ : 57001-1114**  
**Valve Seat Cutter,  $32^\circ - \phi 28$ : 57001-1119**  
**Valve Seat Cutter Holder,  $\phi 4.5$ : 57001-1330**  
**Valve Seat Cutter Holder Bar: 57001-1128**  
**Piston Pin Puller Assembly: 57001-910**  
**Spark Plug Wrench, 16mm (Owner's Tool): 92110-1154**

**Sealant – Kawasaki Bond (Silicone Sealant): 56019-120**

## Clean Air System

### Air Suction Valve Inspection

- Visually inspect the reeds [A] for cracks, folds, warps, heat damage, or other damage.
- ★ If there is any doubt as to the condition of the reed, replace the air suction valve as an assembly.
- Check the reed contact areas [B] of the valve holder for grooves, scratches, any signs of separation from the holder, or heat damage.
- ★ If there is any doubt as to the condition of the reed contact areas, replace the air suction valve as an assembly.
- ★ If any carbon or other foreign particles have accumulated between the reed and the reed contact area, wash the valve assembly with a high flash-point solvent.

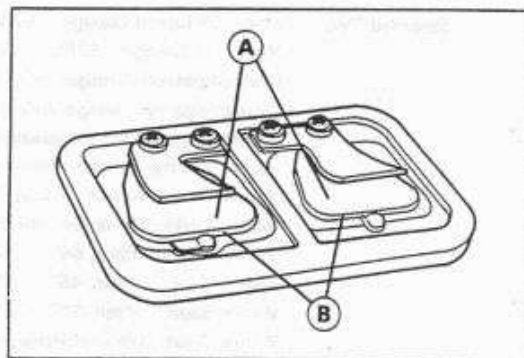

### CAUTION

Do not scrape off the deposits with a scraper as this could damage the rubber, requiring replacement of the suction valve assembly.

### Vacuum Switch Valve Removal

- Remove:
  - Seats (see Frame chapter)
  - Air Cleaner Housing (see Fuel System chapter)
  - Vacuum Switch Valve [A]

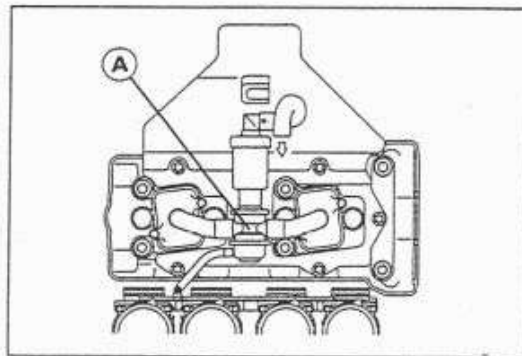

### Vacuum Switch Valve Installation

- Install the vacuum switch valve so that the air hole [A] faces downwards.
- Route the hoses correctly (see General Information chapter).

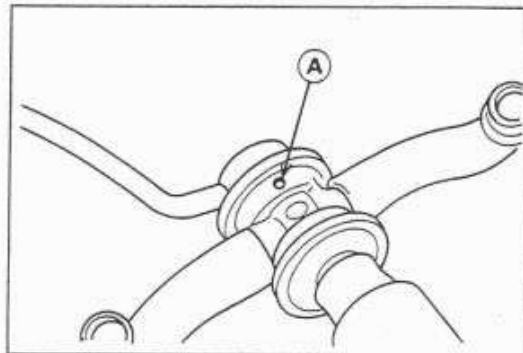

### Vacuum Switch Valve Test

Using the vacuum gauge and a syringe, inspect the vacuum switch valve operation as follows:

- Remove the vacuum switch valve.
- Connect the vacuum gauge [A] and syringe [B] or fork oil level gauge to the vacuum hoses as shown.

**Special Tool – Vacuum Gauge: 57001-1369**  
**Fork Oil Level Gauge: 57001-1290**

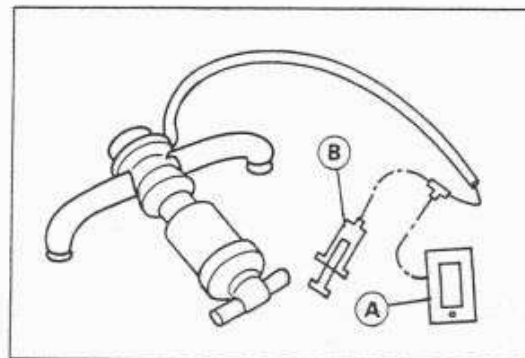

- Gradually raise the vacuum (lower the pressure) applied to the vacuum switch valve, and check the valve operation. When the vacuum is low, the vacuum switch valve should permit air to flow. When the vacuum raises to 57 ~ 65 kPa (430 ~ 490 mm Hg), it should stop air flow.
- ★ If the vacuum switch valve does not operate as described, replace it with a new one.

#### NOTE

○ To check air flow through the vacuum switch valve, just blow through the air cleaner hose.

**Vacuum Switch Valve Closing Pressure (Open → Close)**  
**Standard: 57 ~ 65 kPa (430 ~ 490 mmHg)**

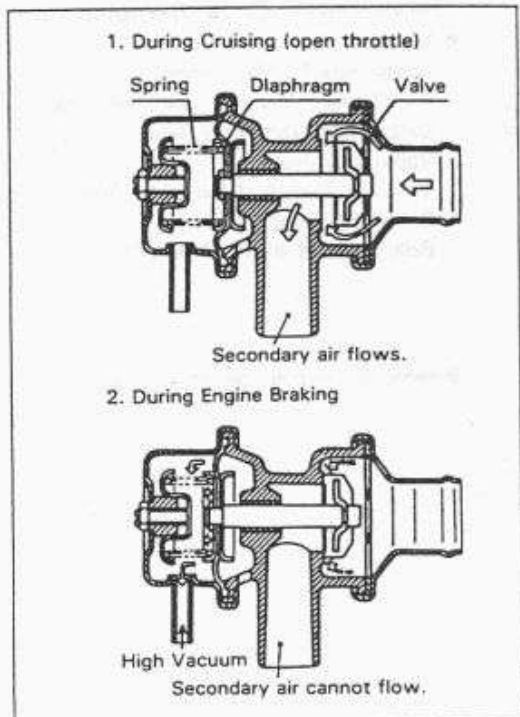

#### Clean Air System Hose Inspection

- Be certain that all the hoses are routed without being flattened or kinked, and are connected correctly to the air cleaner housing, vacuum switch valve, #1 and #4 carburetors and air suction valve covers.
- ★ If they are not, correct them. Replace them if they are damaged.

Cylinder Head Cover

*Cylinder Head Cover Removal*

- Remove:
  - Seats (see Frame chapter)
  - Air Cleaner Housing (see Fuel System chapter)
  - Carburetors (see Fuel System chapter)
  - Vacuum Valve
  - Vacuum Switch Valve and Hoses
  - Spark Plug Caps [A]
  - Bolt [B] and Baffle Plate [C]

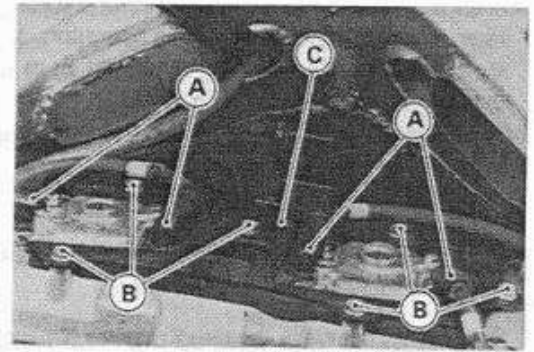

- Remove the cylinder head cover bolts [A] and take off the cover [B].

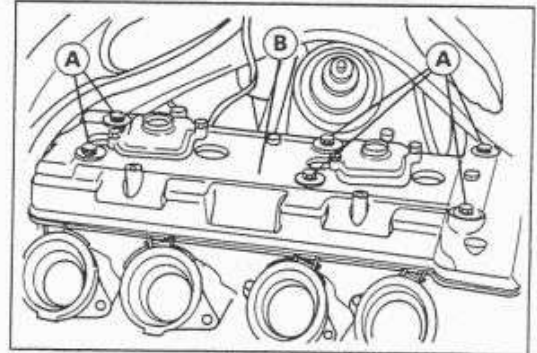

*Cylinder Head Cover Installation*

- Apply silicone sealant [A] to the cylinder head as shown.
  - Sealant – Kawasaki Bond (Silicone Sealant): 56019-120

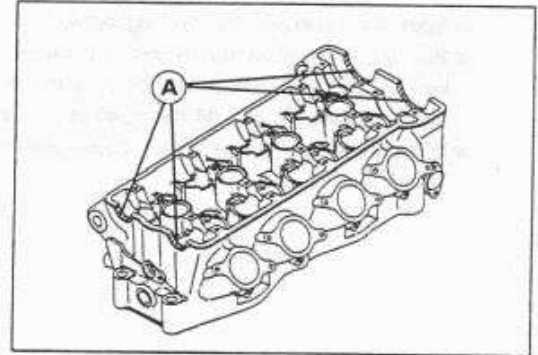

- Apply silicone sealant [A] to the camshaft cap as shown.
  - Sealant – Kawasaki Bond (Silicone Sealant): 56019-120

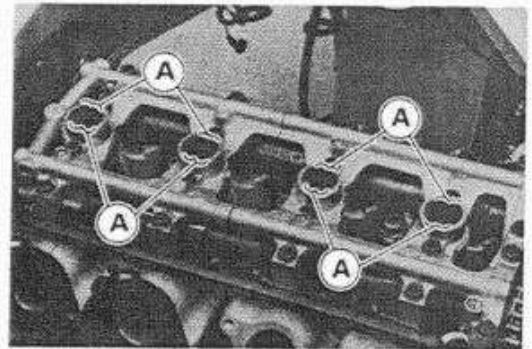

- Replace the head cover gasket with a new one if damaged.
- When the air suction pipes [A] are removed, install the pipes with the one O-ring [B] side faces upward.
- Be sure install the rubber gaskets [C].

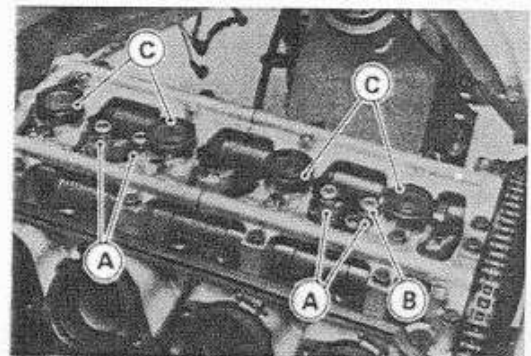

- Check that the upper chain guide [A] bottoms out in the head cover.

**CAUTION**

If the upper chain guide does not bottom out, the camshaft chain can raise the guide and the cylinder head cover which could cause oil leakage.

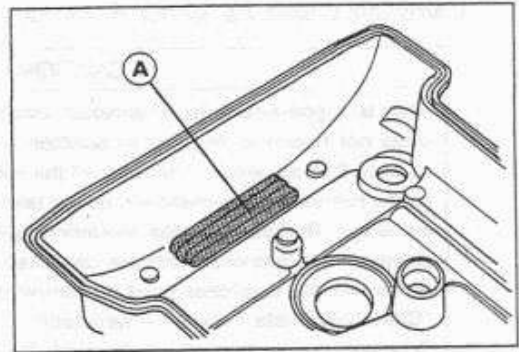

- Install the washers with the metal side [A] faces upward.
- Tighten the cylinder head cover bolts [B].

**Torque – Cylinder Head Cover Bolts: 9.8 N-m (1.0 kg-m, 87 in-lb)**

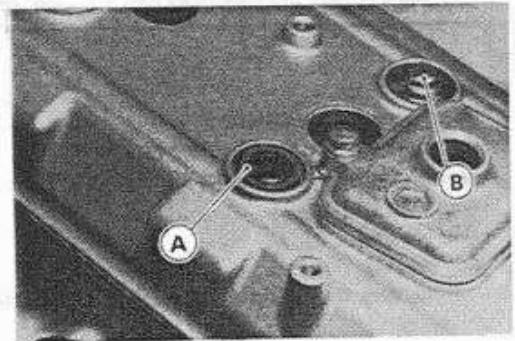

## Camshaft Chain Tensioner

## Camshaft Chain Tensioner Removal

## CAUTION

This is a non-return type camshaft chain tensioner. The push rod does not return to its original position once it moves out to take up camshaft chain slack. Observe all the rules listed below:

When removing the tensioner, do not take out the mounting bolts only halfway. Retightening the mounting bolts from this position could damage the tensioner and the camshaft chain. Once the bolts are loosened, the tensioner must be removed and reset as described in "Camshaft Chain Tensioner Installation."

Do not turn over the crankshaft while the tensioner is removed. This could upset the camshaft chain timing, and damage the valves.

- Remove:
  - Seats (see Frame chapter)
  - Carburetors (see Fuel System chapter)
  - #3, #4 Carburetor Holders
  - Cap Bolt [A]
  - Washer [B]
  - Spring [C]
- Remove the mounting bolts [D] and take off the camshaft chain tensioner.

## Camshaft Chain Tensioner Installation

- Release the stopper [A] and push the rod [B] into the tensioner body [C].
- Install the tensioner body so that the stopper faces upward.

- Apply a non-permanent locking agent to the threads of the tensioner mounting bolts [A] and tighten them.

**Torque – Camshaft Chain Tensioner Mounting Bolts: 12 N-m (1.2 kg-m, 104 in-lb)**

- Install the spring and washer.
- Tighten the cap bolt [B].

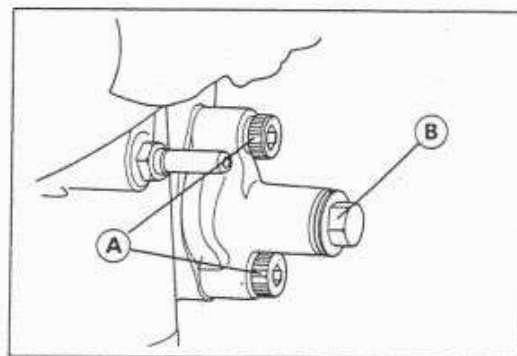
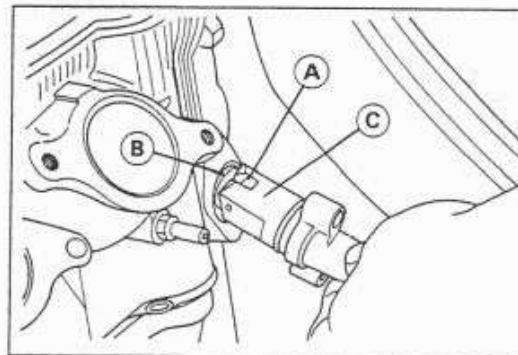
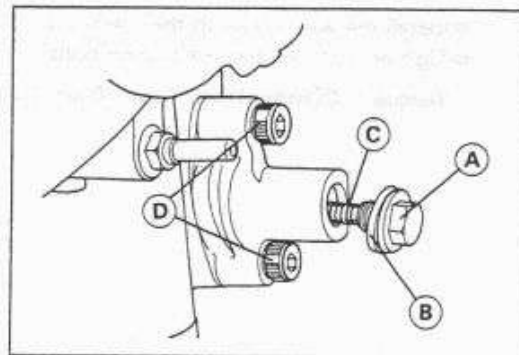



## Camshaft, Camshaft Chain

### Camshaft Removal

- Remove:
  - Cylinder Head Cover (see Cylinder Head Cover Removal)
  - Pickup Coil Cover
- Position the crankshaft at #1, 4 piston TDC.
  - [A] TDC mark for #1, 4 Pistons
  - [B] Timing Mark
- Remove the camshaft chain tensioner (see Camshaft Chain Tensioner Removal).

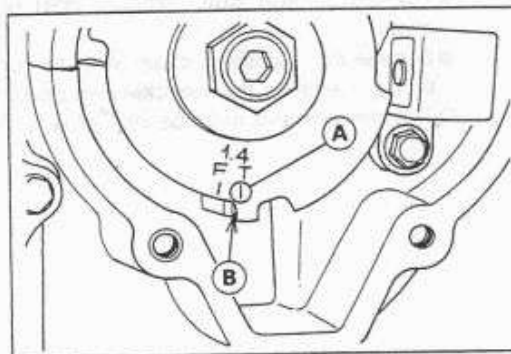

- Remove the camshaft cap bolts gradually in the reverse order of installation (see Camshaft Installation).
- Remove:
  - Camshaft Caps [A]
  - Camshafts [B]
- Stuff a clean cloth into the chain tunnel to keep any parts from dropping into the crankcase.

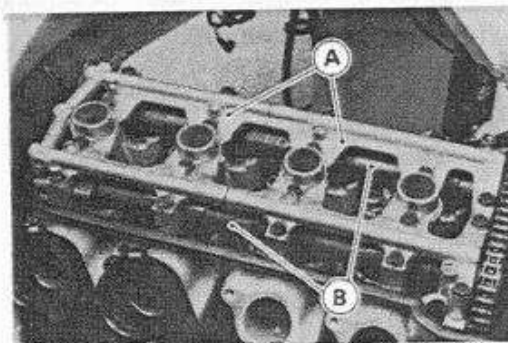

#### CAUTION

The crankshaft may be turned while the camshafts are removed. Always pull the chain taut while turning the crankshaft. This avoids kinking the chain on the lower (crankshaft) sprocket. A kinked chain could damage both the chain and the sprocket.

### Camshaft Installation

- Apply engine oil to all cam parts and journals.
- If a new camshaft is to be used, apply a thin coat of molybdenum disulfide grease to the cam surfaces.

#### NOTE

- The exhaust camshaft [A] has a groove [B] at the left-hand and the inlet camshaft [C] has no groove. Be careful not to mix them up.

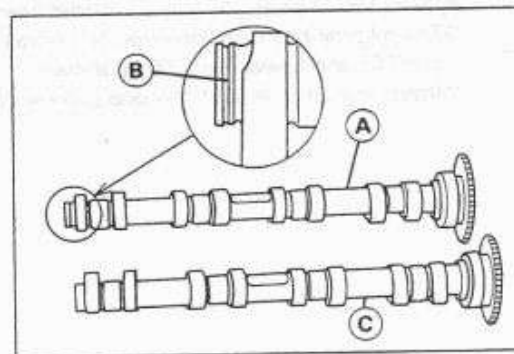

- Position the crankshaft at #1, 4 piston TDC (see Camshaft Removal).

#### CAUTION

Always pull the chain taut while turning the crankshaft. This avoids kinking the chain on the lower (crankshaft) sprocket. A kinked chain could damage both the chain and the sprocket.

- Pull the tension side (exhaust side) of the chain taut to install the chain.
- Engage the camshaft chain with the camshaft sprockets so that the timing marks on the sprockets are positioned as shown.
- The timing marks must be aligned with the cylinder head upper surface [A].

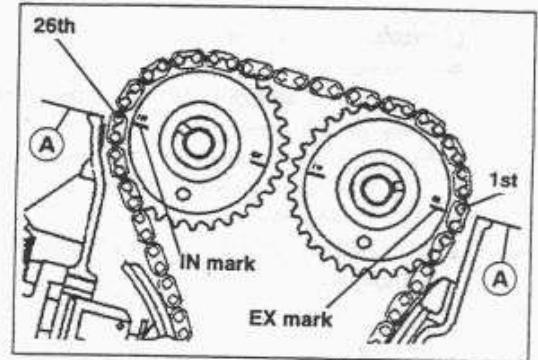

- Push the camshafts toward the left, and attach them to the stoppers [A] of the cylinder head [B].

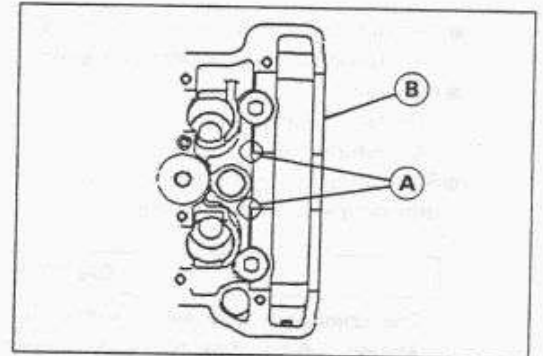

- Be sure to install the following parts.
  - Oil Pipe [A] (see next procedure)
  - Pins [B]
  - Set Rings [C]
  - O-rings [D]

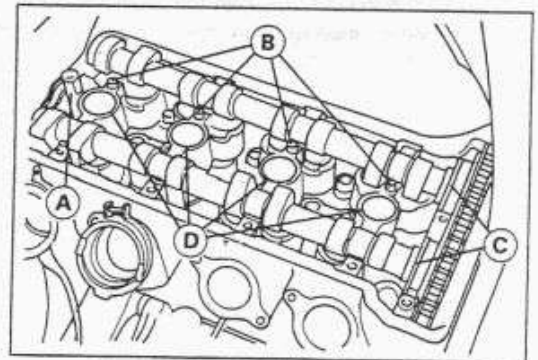

- Insert the oil pipe [A] in the cylinder head [B] as follows:
  - The oil pipe has three grooves, but install the two O-rings in the upper end [C] and lower end [D] as shown.
  - Install the oil pipe with the one groove side faces upward.

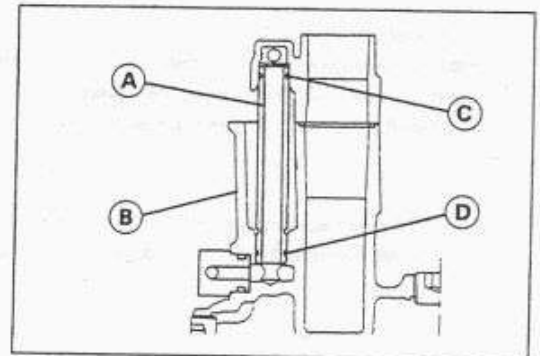

- Tighten the camshaft cap bolts following the tightening sequence [1 ~ 20].
  - [1, 4, 5, 7] Bolts : 6 mm × 46 mm
  - [other than 1, 4, 5, 7] Bolts : 6 mm × 38 mm

**Torque – Camshaft Cap Bolts: 12 N-m (1.2 kg-m, 104 in-lb)**

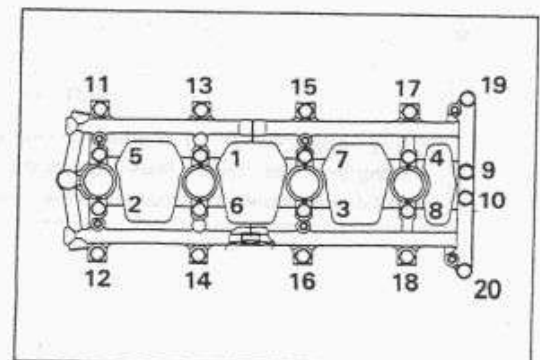

**Camshaft, Camshaft Cap Wear**

- Measure each clearance between the camshaft journal and the camshaft cap using plastigage (press gauge) [A].
- Tighten the camshaft cap bolts.

**Torque – Camshaft Cap Bolts: 12 N-m(1.2 kg-m, 104 in-lb)**

**NOTE**

- Do not turn the camshaft when the plastigage is between the journal and camshaft cap.

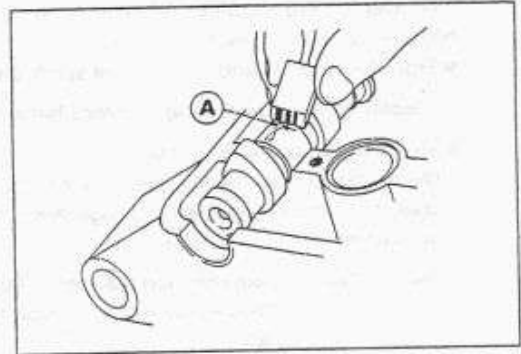

- ★ If any clearance exceeds the service limit, measure the diameter of each camshaft journal with a micrometer.

**Camshaft Journal, Camshaft Cap Clearance**

**Standard:** 0.048 ~ 0.091 mm  
**Service Limit:** 0.18 mm

- ★ If the camshaft journal diameter is less than the service limit, replace the camshaft with a new one and measure the clearance again.
- ★ If the clearance still remains out of the limit, replace the cylinder head unit.

**Camshaft Chain Removal**

- Split the crankcase (see Crankshaft/Transmission chapter).
- Remove the camshaft chain [A] from the crankshaft sprocket.

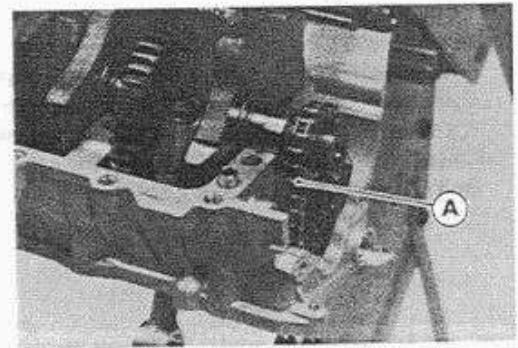
**Camshaft Chain Wear**

- Hold the chain taut with a force of about 5 kg in some manner, and measure a 20-link length. Since the chain may wear unevenly, take measurement at several places.
- ★ If any measurement exceeds the service limit, replace the chain.

**Camshaft Chain 20-link Length**

**Standard:** 155.5 ~ 155.8 mm  
**Service Limit:** 157.8 mm

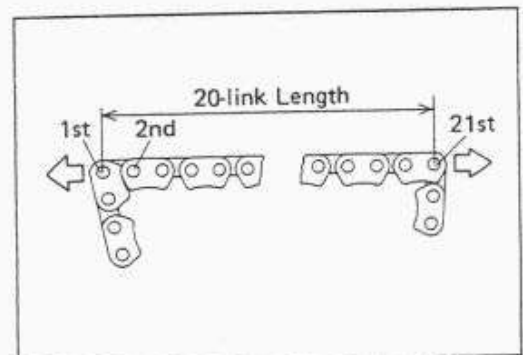

## Cylinder Head

### Cylinder Compression Measurement

- Warm up the engine thoroughly.
- Stop the engine, and remove the spark plugs.

**Special Tool – Spark Plug Wrench, 16mm: 92110-1154**

- Measure the cylinder compression.
- Using the starter motor, turn the engine over with the throttle fully open until the compression gauge stops rising; the compression is the highest reading obtainable.

**Special Tool – Compression Gauge: 57001-221 [A]  
Compression Gauge Adapter, M10 X 1.0: 57001-1317 [B]**

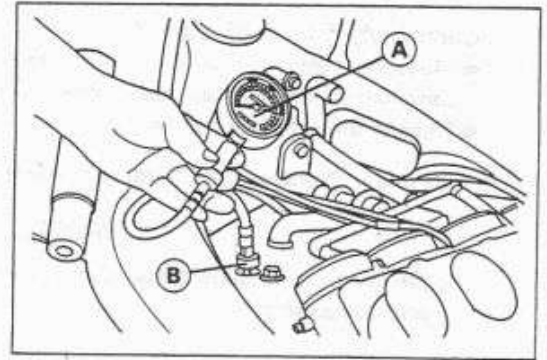

### NOTE

- Be sure the battery is fully charged.
- Be sure no air leaks out of the cylinder head gasket.

### Cylinder Compression

**Usable Range : 1030 ~ 1570 kPa (10.5 ~ 16.0 kg/cm<sup>2</sup>,  
149 ~ 228 psi) @ 360 r/min (rpm)**

- Repeat the measurement for the other cylinder.
- ★ If cylinder compression is higher than the usable range, check the following:
  - (1) Carbon build-up on the cylinder head combustion chamber and the piston crown.
  - (2) Cylinder head gasket is not the original part.
  - (3) Valve stem oil seals and/or piston rings are damaged.
- ★ If cylinder compression is lower than the usable range, check the following:
  - (1) Condition of the valve seat is wrong.
  - (2) Valve clearance is too small.
  - (3) Piston/cylinder clearance is excessive.
  - (4) Cylinder head is warped and/or head gasket is damaged.
  - (5) Piston ring/piston ring groove clearance is excessive.

### Cylinder Head Removal

- Remove:
  - Engine (see Engine Removal/Installation chapter)
  - Cylinder Head Cover (see Cylinder Head Cover Removal)
  - Camshaft Chain Tensioner (see Camshaft Chain Tensioner Removal)
  - Camshafts (see Camshaft Removal)
  - Bolt [A] and Oil Pipe [B]

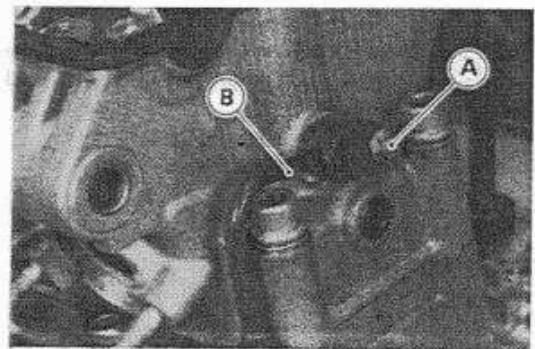

Bolts [A] and Engine Damper Cover [B]

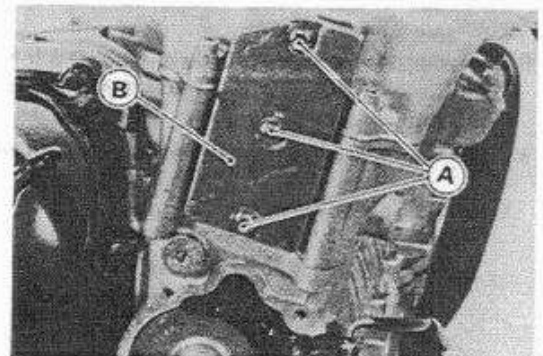

- Remove the 6 mm cylinder head bolts [A], and then the 10 mm cylinder head bolts [B].
- Take off the cylinder head.

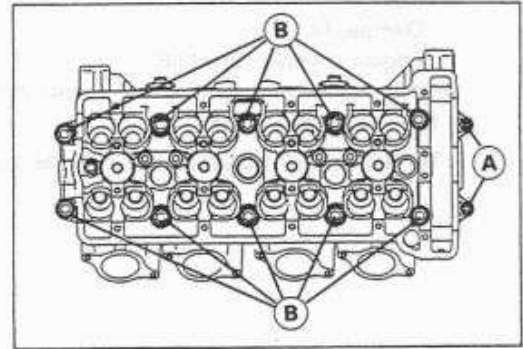

### Cylinder Head Installation

#### NOTE

○ The camshaft caps are machined with the cylinder head so if a new cylinder head is installed, use the caps that are supplied with the new head.

- Install:
  - Pins [A]
  - New Cylinder Head Gasket [B]

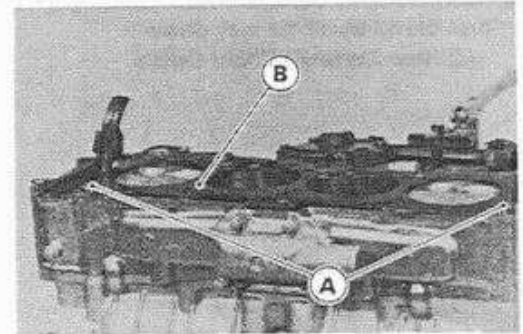

- Apply engine oil to both sides [A] of the cylinder head bolt washers.

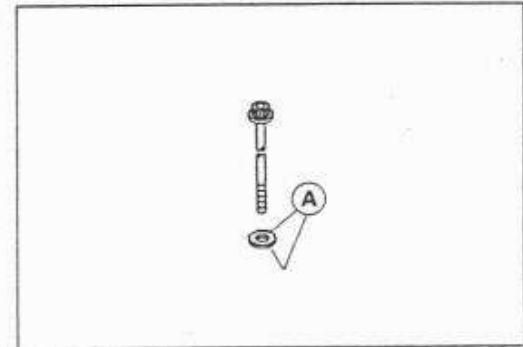

- Tighten the 10 mm cylinder head bolts following the tightening sequence [1 ~ 10].

- [1, 2, 4, 6, 8] Bolts: 10 mm x 151 mm
- [3, 5, 7] Bolts: 10 mm x 165 mm
- [9, 10] Bolts: 10 mm x 137 mm

#### Torque - Cylinder Head Bolts (10mm):

<b>First</b>	<b>20 N-m (2.0 kg-m, 14.5 ft-lb)</b>
<b>Final</b>	<b>44 N-m (4.5 kg-m, 33 ft-lb)</b>

- Tighten the 6 mm cylinder head bolts [11 ~ 12].

**Torque - Cylinder Head Bolts (6 mm): 12 N-m (1.2 kg-m, 104 in-lb)**

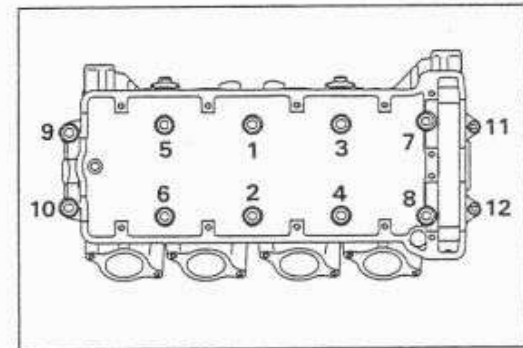

- Apply engine oil to the O-ring [A] on the oil pipe.
- Tighten the oil pipe bolt.

**Torque - Oil Pipe Bolt: 9.8 N-m (1.0 kg-m, 87 in-lb)**

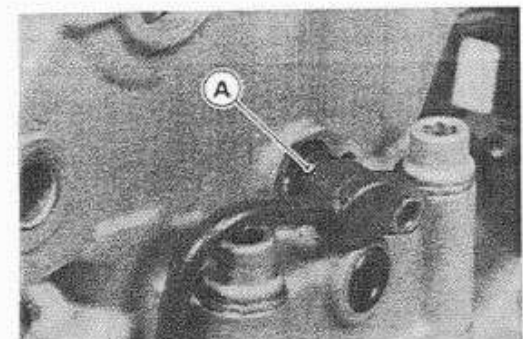

● Install:

Damper [A]

Engine Damper Cover [B]

- Apply a non-permanent locking agent to the threads of the cover bolts [C], and tighten them.

**Torque – Engine Damper Cover Bolts: 9.8 N-m (1.0 kg-m, 87 in-lb)**

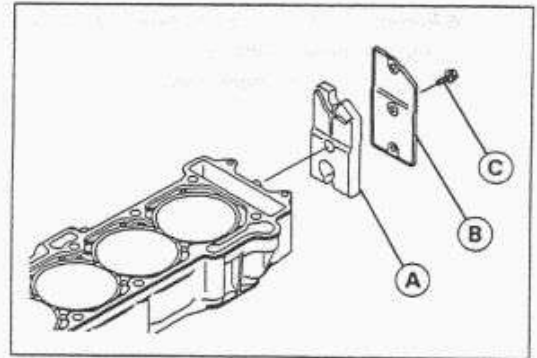

- Install the front camshaft chain guide [A] with its projection [B] up. Push the guide all the way down.
- [C] Rear Camshaft Chain Guide

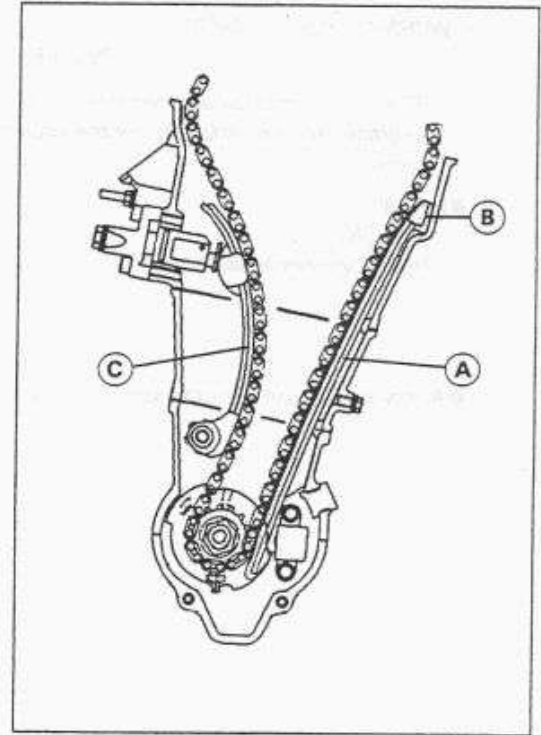

Valves

Valve Clearance Inspection

NOTE

○ Valve clearance must be checked and adjusted when the engine is cold (at room temperature).

- Remove:
  - Right Lower Fairing (see Frame chapter)
  - Coolant Reserve Tank
  - Pickup Coil Cover
  - Cylinder Head Cover (see Cylinder Head Cover Removal)
- Position the crankshaft at #1.4 piston TDC and then turn it 360°.
- Using a thickness gauge [A], measure the valve clearance between the cam [B] and the valve lifter [C].
- When positioning #4 piston TDC at the end of the compression stroke:
  - Inlet valve clearance of #2 and #4 cylinders
  - Exhaust valve clearance of #3 and #4 cylinders

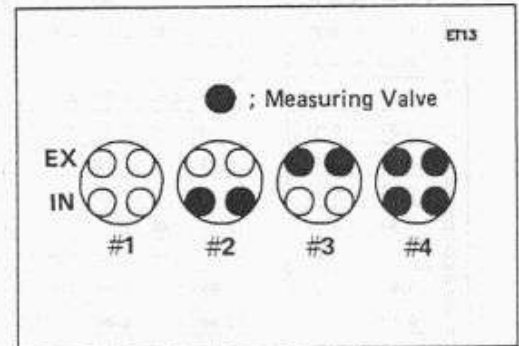
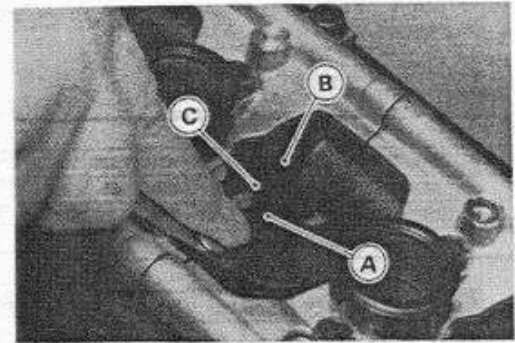

- When positioning #1 piston TDC at the end of the compression stroke:
  - Inlet valve clearance of #1 and #3 cylinders
  - Exhaust valve clearance of #1 and #2 cylinders

Valve Clearance

Standard: EX: 0.22 ~ 0.31 mm  
IN: 0.17 ~ 0.25 mm

★ If the valve clearance is not within the specified range, first record the clearance, and then adjust it.

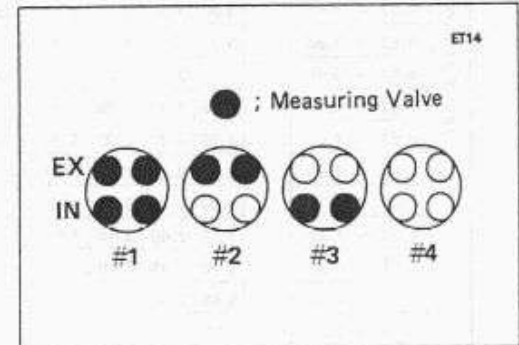

Valve Clearance Adjustment

- Remove:
  - Camshafts [A] (see Camshaft Removal)
  - Valve Lifter [B]
  - Shim [C]
- Referring to the Valve Clearance Adjustment Chart, select a new shim which brings valve clearance within the specified range, and replace the original shim with the selected new one.

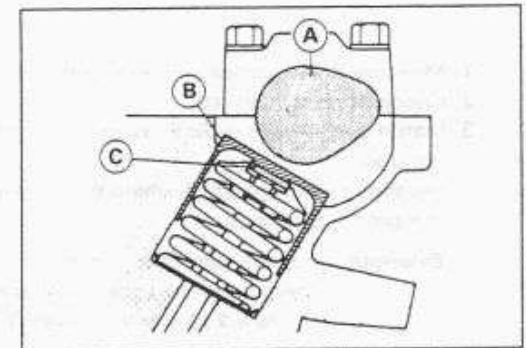

CAUTION

Do not put shim stock under the shim. This may cause the shim to pop out at high rpm, causing extensive engine damage.  
Do not grind the shim. This may cause it to fracture, causing extensive engine damage.

- Apply engine oil to the valve lifter and install it.
- Install the camshaft (see Camshaft Installation).

VALVE CLEARANCE ADJUSTMENT CHART

EXHAUST VALVE

PART No. (92180 -)	PRESENT SHIM																				
	1014	1016	1018	1020	1022	1024	1026	1028	1030	1032	1034	1036	1038	1040	1042	1044	1046	1048	1050	1052	1054
MARK	50	55	60	65	70	75	80	85	90	95	00	05	10	15	20	25	30	35	40	45	50
THICKNESS (mm)	2.50	2.55	2.60	2.65	2.70	2.75	2.80	2.85	2.90	2.95	3.00	3.05	3.10	3.15	3.20	3.25	3.30	3.35	3.40	3.45	3.50

VALVE CLEARANCE MEASUREMENT	PRESENT SHIM																				
	1014	1016	1018	1020	1022	1024	1026	1028	1030	1032	1034	1036	1038	1040	1042	1044	1046	1048	1050	1052	1054
0.00 ~ 0.01						2.50	2.55	2.60	2.65	2.70	2.75	2.80	2.85	2.90	2.95	3.00	3.05	3.10	3.15	3.20	3.25
0.02 ~ 0.06					2.50	2.55	2.60	2.65	2.70	2.75	2.80	2.85	2.90	2.95	3.00	3.05	3.10	3.15	3.20	3.25	3.30
0.07 ~ 0.11				2.50	2.55	2.60	2.65	2.70	2.75	2.80	2.85	2.90	2.95	3.00	3.05	3.10	3.15	3.20	3.25	3.30	3.35
0.12 ~ 0.16			2.50	2.55	2.60	2.65	2.70	2.75	2.80	2.85	2.90	2.95	3.00	3.05	3.10	3.15	3.20	3.25	3.30	3.35	3.40
0.17 ~ 0.21		2.50	2.55	2.60	2.65	2.70	2.75	2.80	2.85	2.90	2.95	3.00	3.05	3.10	3.15	3.20	3.25	3.30	3.35	3.40	3.45
0.22 ~ 0.31																					
0.32 ~ 0.36	2.55	2.60	2.65	2.70	2.75	2.80	2.85	2.90	2.95	3.00	3.05	3.10	3.15	3.20	3.25	3.30	3.35	3.40	3.45	3.50	
0.37 ~ 0.41	2.60	2.65	2.70	2.75	2.80	2.85	2.90	2.95	3.00	3.05	3.10	3.15	3.20	3.25	3.30	3.35	3.40	3.45	3.50		
0.42 ~ 0.46	2.65	2.70	2.75	2.80	2.85	2.90	2.95	3.00	3.05	3.10	3.15	3.20	3.25	3.30	3.35	3.40	3.45	3.50			
0.47 ~ 0.51	2.70	2.75	2.80	2.85	2.90	2.95	3.00	3.05	3.10	3.15	3.20	3.25	3.30	3.35	3.40	3.45	3.50				
0.52 ~ 0.56	2.75	2.80	2.85	2.90	2.95	3.00	3.05	3.10	3.15	3.20	3.25	3.30	3.35	3.40	3.45	3.50					
0.57 ~ 0.61	2.80	2.85	2.90	2.95	3.00	3.05	3.10	3.15	3.20	3.25	3.30	3.35	3.40	3.45	3.50						
0.62 ~ 0.66	2.85	2.90	2.95	3.00	3.05	3.10	3.15	3.20	3.25	3.30	3.35	3.40	3.45	3.50							
0.67 ~ 0.71	2.90	2.95	3.00	3.05	3.10	3.15	3.20	3.25	3.30	3.35	3.40	3.45	3.50								
0.72 ~ 0.76	2.95	3.00	3.05	3.10	3.15	3.20	3.25	3.30	3.35	3.40	3.45	3.50									
0.77 ~ 0.81	3.00	3.05	3.10	3.15	3.20	3.25	3.30	3.35	3.40	3.45	3.50										
0.82 ~ 0.86	3.05	3.10	3.15	3.20	3.25	3.30	3.35	3.40	3.45	3.50											
0.87 ~ 0.91	3.10	3.15	3.20	3.25	3.30	3.35	3.40	3.45	3.50												
0.92 ~ 0.96	3.15	3.20	3.25	3.30	3.35	3.40	3.45	3.50													
0.97 ~ 1.01	3.20	3.25	3.30	3.35	3.40	3.45	3.50														
1.02 ~ 1.06	3.25	3.30	3.35	3.40	3.45	3.50															
1.07 ~ 1.11	3.30	3.35	3.40	3.45	3.50																
1.12 ~ 1.16	3.35	3.40	3.45	3.50																	
1.17 ~ 1.21	3.40	3.45	3.50																		
1.22 ~ 1.26	3.45	3.50																			
1.27 ~ 1.31	3.50																				

INSTALL THE SHIM OF THIS THICKNESS (mm)

1. Measure the clearance (when engine is cold).
2. Check present shim size.
3. Match clearance in vertical column with present shim size in horizontal column.
4. Install the shim specified where the lines intersect. This shim will give the proper clearance.  
**Example:** Present shim is 3.10 mm.  
 Measured clearance is 0.40 mm.  
 Replace 3.10 mm shim with 3.20 mm shim.
5. Remeasure the valve clearance and readjust if necessary.

**CAUTION**

Be sure to remeasure the clearance after selecting a shim according to the table. The clearance can be out of the specified range because of the shim tolerance.

**NOTE**

○ If there is no clearance, select a shim which is several sizes smaller and then measure the clearance.



VALVE CLEARANCE ADJUSTMENT CHART

INLET VALVE

PART No. (92180 -)	PRESENT SHIM																				
	1014	1016	1018	1020	1022	1024	1026	1028	1030	1032	1034	1036	1038	1040	1042	1044	1046	1048	1050	1052	1054
MARK	50	55	60	65	70	75	80	85	90	95	00	05	10	15	20	25	30	35	40	45	50
THICKNESS (mm)	2.50	2.55	2.60	2.65	2.70	2.75	2.80	2.85	2.90	2.95	3.00	3.05	3.10	3.15	3.20	3.25	3.30	3.35	3.40	3.45	3.50

VALVE CLEARANCE MEASUREMENT	PRESENT SHIM																				
	2.50	2.55	2.60	2.65	2.70	2.75	2.80	2.85	2.90	2.95	3.00	3.05	3.10	3.15	3.20	3.25	3.30	3.35	3.40	3.45	3.50
0.00 ~ 0.01					2.50	2.55	2.60	2.65	2.70	2.75	2.80	2.85	2.90	2.95	3.00	3.05	3.10	3.15	3.20	3.25	3.30
0.02 ~ 0.06				2.50	2.55	2.60	2.65	2.70	2.75	2.80	2.85	2.90	2.95	3.00	3.05	3.10	3.15	3.20	3.25	3.30	3.35
0.07 ~ 0.11			2.50	2.55	2.60	2.65	2.70	2.75	2.80	2.85	2.90	2.95	3.00	3.05	3.10	3.15	3.20	3.25	3.30	3.35	3.40
0.12 ~ 0.16		2.50	2.55	2.60	2.65	2.70	2.75	2.80	2.85	2.90	2.95	3.00	3.05	3.10	3.15	3.20	3.25	3.30	3.35	3.40	3.45
0.17 ~ 0.25	SPECIFIED CLEARANCE/NO CHANGE REQUIRED																				
0.26 ~ 0.30	2.55	2.60	2.65	2.70	2.75	2.80	2.85	2.90	2.95	3.00	3.05	3.10	3.15	3.20	3.25	3.30	3.35	3.40	3.45	3.50	
0.31 ~ 0.35	2.60	2.65	2.70	2.75	2.80	2.85	2.90	2.95	3.00	3.05	3.10	3.15	3.20	3.25	3.30	3.35	3.40	3.45	3.50		
0.36 ~ 0.40	2.65	2.70	2.75	2.80	2.85	2.90	2.95	3.00	3.05	3.10	3.15	3.20	3.25	3.30	3.35	3.40	3.45	3.50			
0.41 ~ 0.45	2.70	2.75	2.80	2.85	2.90	2.95	3.00	3.05	3.10	3.15	3.20	3.25	3.30	3.35	3.40	3.45	3.50				
0.46 ~ 0.50	2.75	2.80	2.85	2.90	2.95	3.00	3.05	3.10	3.15	3.20	3.25	3.30	3.35	3.40	3.45	3.50					
0.51 ~ 0.55	2.80	2.85	2.90	2.95	3.00	3.05	3.10	3.15	3.20	3.25	3.30	3.35	3.40	3.45	3.50						
0.56 ~ 0.60	2.85	2.90	2.95	3.00	3.05	3.10	3.15	3.20	3.25	3.30	3.35	3.40	3.45	3.50							
0.61 ~ 0.65	2.90	2.95	3.00	3.05	3.10	3.15	3.20	3.25	3.30	3.35	3.40	3.45	3.50								
0.66 ~ 0.70	2.95	3.00	3.05	3.10	3.15	3.20	3.25	3.30	3.35	3.40	3.45	3.50									
0.71 ~ 0.75	3.00	3.05	3.10	3.15	3.20	3.25	3.30	3.35	3.40	3.45	3.50										
0.76 ~ 0.80	3.05	3.10	3.15	3.20	3.25	3.30	3.35	3.40	3.45	3.50											
0.81 ~ 0.85	3.10	3.15	3.20	3.25	3.30	3.35	3.40	3.45	3.50												
0.86 ~ 0.90	3.15	3.20	3.25	3.30	3.35	3.40	3.45	3.50													
0.91 ~ 0.95	3.20	3.25	3.30	3.35	3.40	3.45	3.50														
0.96 ~ 1.00	3.25	3.30	3.35	3.40	3.45	3.50															
1.01 ~ 1.05	3.30	3.35	3.40	3.45	3.50																
1.06 ~ 1.10	3.35	3.40	3.45	3.50																	
1.11 ~ 1.15	3.40	3.45	3.50																		
1.16 ~ 1.20	3.45	3.50																			
1.21 ~ 1.25	3.50																				

INSTALL THE SHIM OF THIS THICKNESS (mm)

1. Measure the clearance (when engine is cold).
2. Check present shim size.
3. Match clearance in vertical column with present shim size in horizontal column.
4. Install the shim specified where the lines intersect. This shim will give the proper clearance.
 

**Example:** Present shim is 3.05 mm  
Measured clearance is 0.45 mm  
Replace 3.05 mm shim with 3.25 mm shim.
5. Remeasure the valve clearance and readjust if necessary.

**CAUTION**

Be sure to remeasure the clearance after selecting a shim according to the table. The clearance can be out of the specified range because of the shim tolerance.

**NOTE**

○ If there is no clearance, select a shim which is several sizes smaller and then measure the clearance.

## Valve Removal

- Remove the cylinder head (see Cylinder Head Removal).
- Remove the valve lifter and shim.
- Mark and record the shim locations so that the shims can be installed in their original positions.
- Using the valve spring compressor assembly, remove the valve.

**Special Tool – Valve Spring Compressor Assembly: 57001-241 [A]  
Valve Spring Compressor Adapter,  $\Phi$ 22: 57001-1202 [B]**

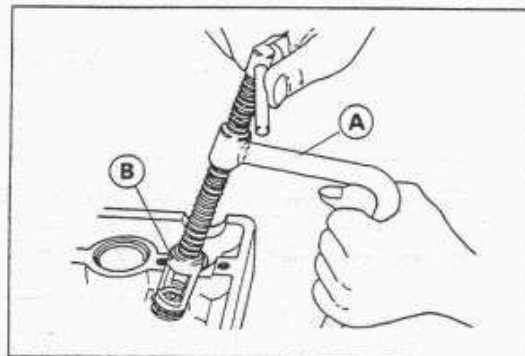

## Valve Installation

- Replace the oil seal with a new one.
  - Apply a thin coat of molybdenum disulfide grease to the valve stem before valve installation.
  - Install the springs so that the closed coil end faces downwards.
- |                  |                     |
|------------------|---------------------|
| [A] Valve Stem   | [E] Inner Spring    |
| [B] Oil Seal     | [F] Retainer        |
| [C] Spring Seat  | [G] Split Keepers   |
| [D] Outer Spring | [H] Closed Coil End |

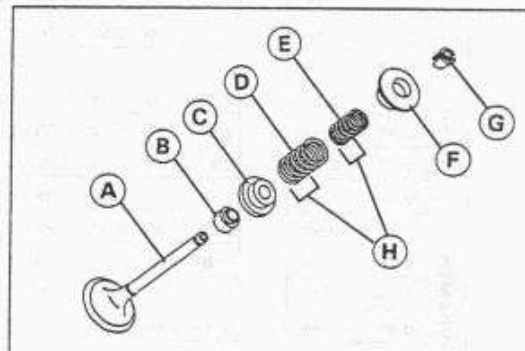

## Valve Guide Removal

- Remove:
  - Valve (see Valve Removal)
  - Oil Seal
  - Spring Seat
- Heat the area around the valve guide to 120 ~ 150°C (248 ~ 302 °F), and hammer lightly on the valve guide arbor [A] to remove the guide from the top of the head.

**Special Tool – Valve Guide Arbor,  $\Phi$ 4.5: 57001-1331**

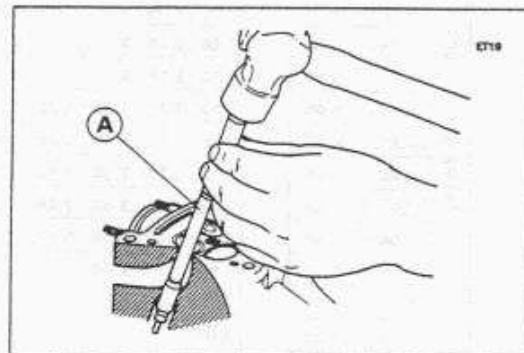

## Valve Guide Installation

- Apply oil to the valve guide outer surface before installation.
- Heat the area around the valve guide hole to about 120 ~ 150 °C (248 ~ 302 °F).
- Drive the valve guide in from the top of the head using the valve guide arbor. The circlip stops the guide from going in too far.

**Special Tool – Valve Guide Arbor,  $\Phi$ 4.5: 57001-1331**

- Ream the valve guide with valve guide reamer [A] even if the old guide is reused.

**Special Tool – Valve Guide Reamer,  $\Phi$ 4.5: 57001-1333**

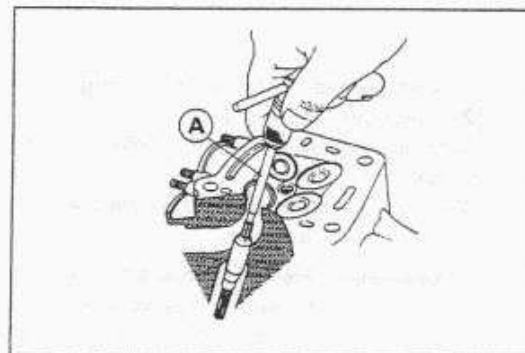

## Valve-to-Guide Clearance Measurement (Wobble Method)

If a small bore gauge is not available, inspect the valve guide wear by measuring the valve to valve guide clearance with the wobble method as indicated below.

- Insert a new valve [A] into the guide [B] and set a dial gauge against the stem perpendicular to it as close as possible to the cylinder head mating surface.
- Move the stem back and forth [C] to measure valve/valve guide clearance.
- Repeat the measurement in a direction at a right angle to the first.
- ★ If the reading exceeds the service limit, replace the guide.

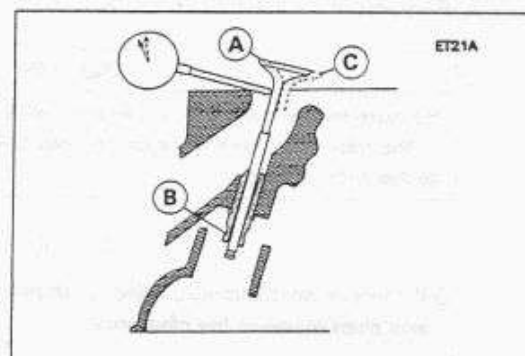

**NOTE**

○ The reading is not actual valve/valve guide clearance because the measuring point is above the guide.

**Valve/Valve Guide Clearance (Wobble Method)**

	Standard	Service Limit
Exhaust	0.090 ~ 0.171 mm	0.37 mm
Inlet	0.031 ~ 0.113 mm	0.32 mm

**Valve Seat Inspection**

- Remove the valve (see Valve Removal).
- Check the valve seating surface [A] between the valve [B] and valve seat [C].
- Measure the outside diameter [D] of the seating pattern on the valve seat.
- ★ If the outside diameter is too large or too small, repair the seat (see Seat Repair).

**Valve Seating Surface Outside Diameter**

Standard:	Exhaust	24.4 ~ 24.6 mm
	Inlet	28.4 ~ 28.6 mm

- Measure the seat width [E] of the portion where there is no build-up carbon (white portion) of the valve seat with a vernier caliper.
- ★ If the width is too wide, too narrow or uneven, repair the seat (see Valve Seat Repair).

**Valve Seating Surface Width**

Standard:	Exhaust, Inlet	0.5 ~ 1.0 mm
-----------	----------------	--------------

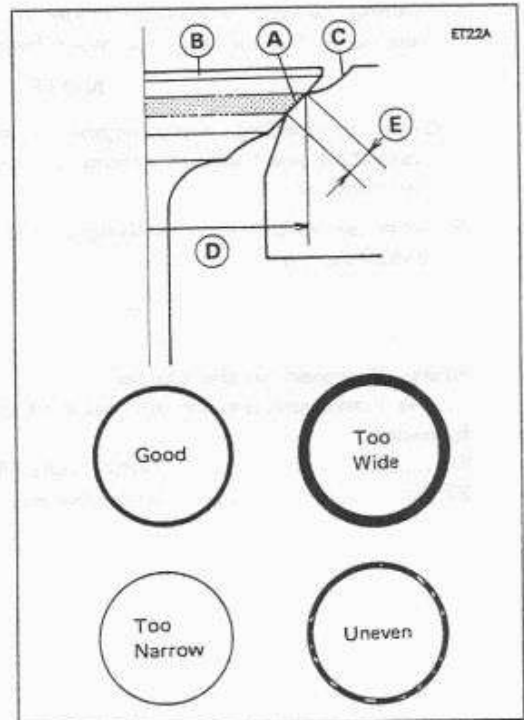

**Valve Seat Repair**

- Repair the valve seat with the valve seat cutters.
- Special Tool – Valve Seat Cutter Holder,  $\Phi$ 4.5: 57001-1330**  
**Valve Seat Cutter Holder Bar: 57001-1128**

**[For Inlet Valve Seat]**

- Valve Seat Cutter, 45° –  $\Phi$ 27.5: 57001-1114
- Valve Seat Cutter, 32° –  $\Phi$ 28: 57001-1119
- Valve Seat Cutter, 60° –  $\Phi$ 30: 57001-1123

**[For Exhaust Valve Seat]**

- Valve Seat Cutter, 45° –  $\Phi$ 27.5: 57001-1114
- Valve Seat Cutter, 32° –  $\Phi$ 28: 57001-1119
- Valve Seat Cutter, 60° –  $\Phi$ 30: 57001-1123

- ★ If the manufacturer's instructions are not available, use the following procedure.

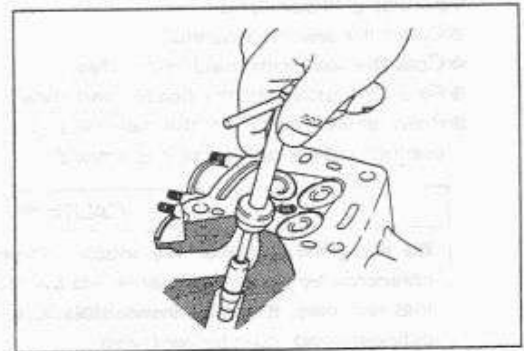

## Seat Cutter Operation Care:

1. This valve seat cutter is developed to grind the valve for repair. Therefore the cutter must not be used for other purposes than seat repair.
2. Do not drop or shock the valve seat cutter, or the diamond particles may fall off.
3. Do not fail to apply engine oil to the valve seat cutter before grinding the seat surface. Also wash off ground particles sticking to the cutter with washing oil.

### NOTE

○ Do not use a wire brush to remove the metal particles from the cutter. It will take off the diamond particles.

4. Setting the valve seat cutter holder in position, operate the cutter in one hand. Do not apply too much force to the diamond portion.

### NOTE

○ Prior to grinding, apply engine oil to the cutter and during the operation, wash off any ground particles sticking to the cutter with washing oil.

5. After use, wash it with washing oil and apply thin layer of engine oil before storing.

## Marks Stamped on the Cutter:

The marks stamped on the back of the cutter [A] represent the following.

60°.....Cutter angle [B]

37.5φ.....Outer diameter of cutter [C]

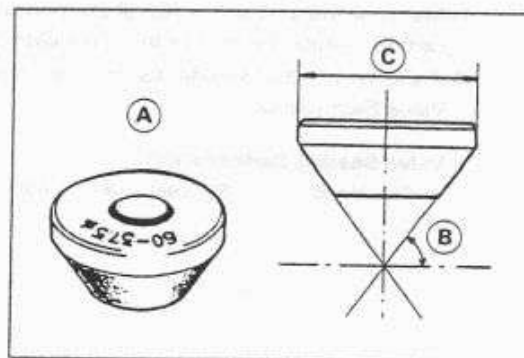

## Operating Procedures:

- Clean the seat area carefully.
- Coat the seat with machinist's dye.
- Fit a 45° cutter into the holder and slide it into the valve guide.
- Press down lightly on the handle and turn it right or left. Grind the seating surface only until it is smooth.

### CAUTION

Do not grind the seat too much. Overgrinding will reduce valve clearance by sinking the valve into the head. If the valve sinks too far into the head, it will be impossible to adjust the clearance, and the cylinder head must be replaced.

- Measure the outside diameter of the seating surface with a vernier caliper.
- ★ If the outside diameter of the seating surface is too small, repeat the 45° grind until the diameter is within the specified range.
- ★ If the outside diameter of the seating surface is too large, make the 32° grind described below.
- ★ If the outside diameter of the seating surface is within the specified range, measure the seat width as described below.
- Grind the seat at a 32° angle until the seat O.D. is within the specified range.

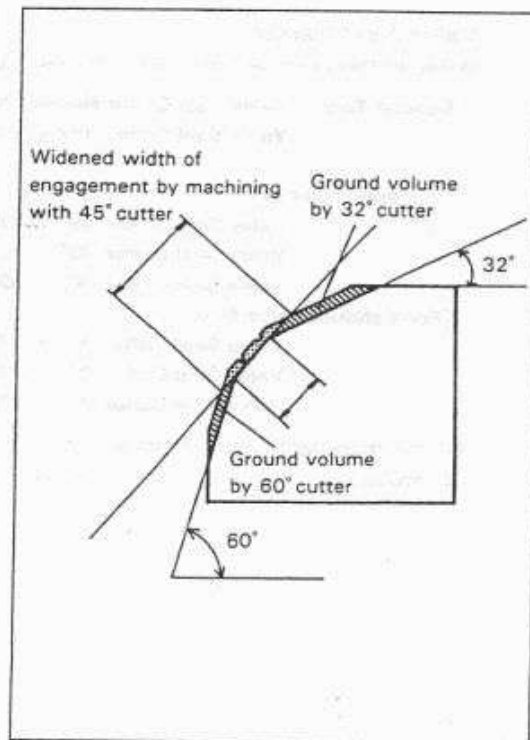

- To make the 32° grind, fit a 32° cutter into the holder, and slide it into the valve guide.
- Turn the holder one turn at a time while pressing down very lightly. Check the seat after each turn.

**CAUTION**

**The 32° cutter removes material very quickly. Check the seat outside diameter frequently to prevent overgrinding.**

- After making the 32° grind, return to the seat O.D. measurement step above.
- To measure the seat width, use a vernier caliper to measure the width of the 45° angle portion of the seat at several places around the seat.
- ★ If the seat width is too narrow, repeat the 45° grind until the seat is slightly too wide, and then return to the seat O.D. measurement step above.
- ★ If the seat width is too wide, make the 60° grind described below.
- ★ If the seat width is within the specified range, lap the valve to the seat as described below.
- Grind the seat at a 60° angle until the seat width is within the specified range.
- To make the 60° grind, fit 60° cutter into the holder, and slide it into the valve guide.
- Turn the holder, while pressing down lightly.
- After making the 60° grind, return to the seat width measurement step above.
- Lap the valve to the seat, once the seat width and O.D. are within the ranges specified above.
- Put a little coarse grinding compound on the face of the valve in a number of places around the valve head.
- Spin the valve against the seat until the grinding compound produces a smooth, matched surface on both the seat and the valve.
- Repeat the process with a fine grinding compound.

- [A] Lapper
- [B] Valve Seat
- [C] Valve

- The seating area should be marked about in the middle of the valve face.
- ★ If the seat area is not in the right place on the valve, check to be sure the valve is the correct part. If it is, it may have been refaced too much; replace it.
- Be sure to remove all grinding compound before assembly.
- When the engine is assembled, be sure to adjust the valve clearance (see Valve Clearance Adjustment).

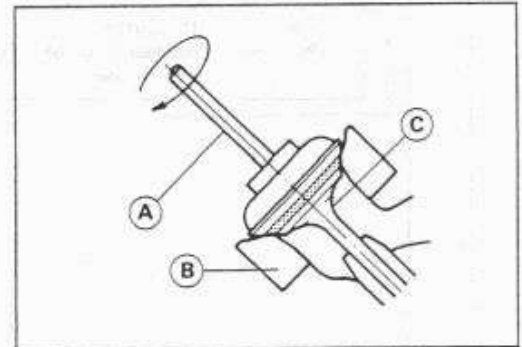

Valve Seat Repair

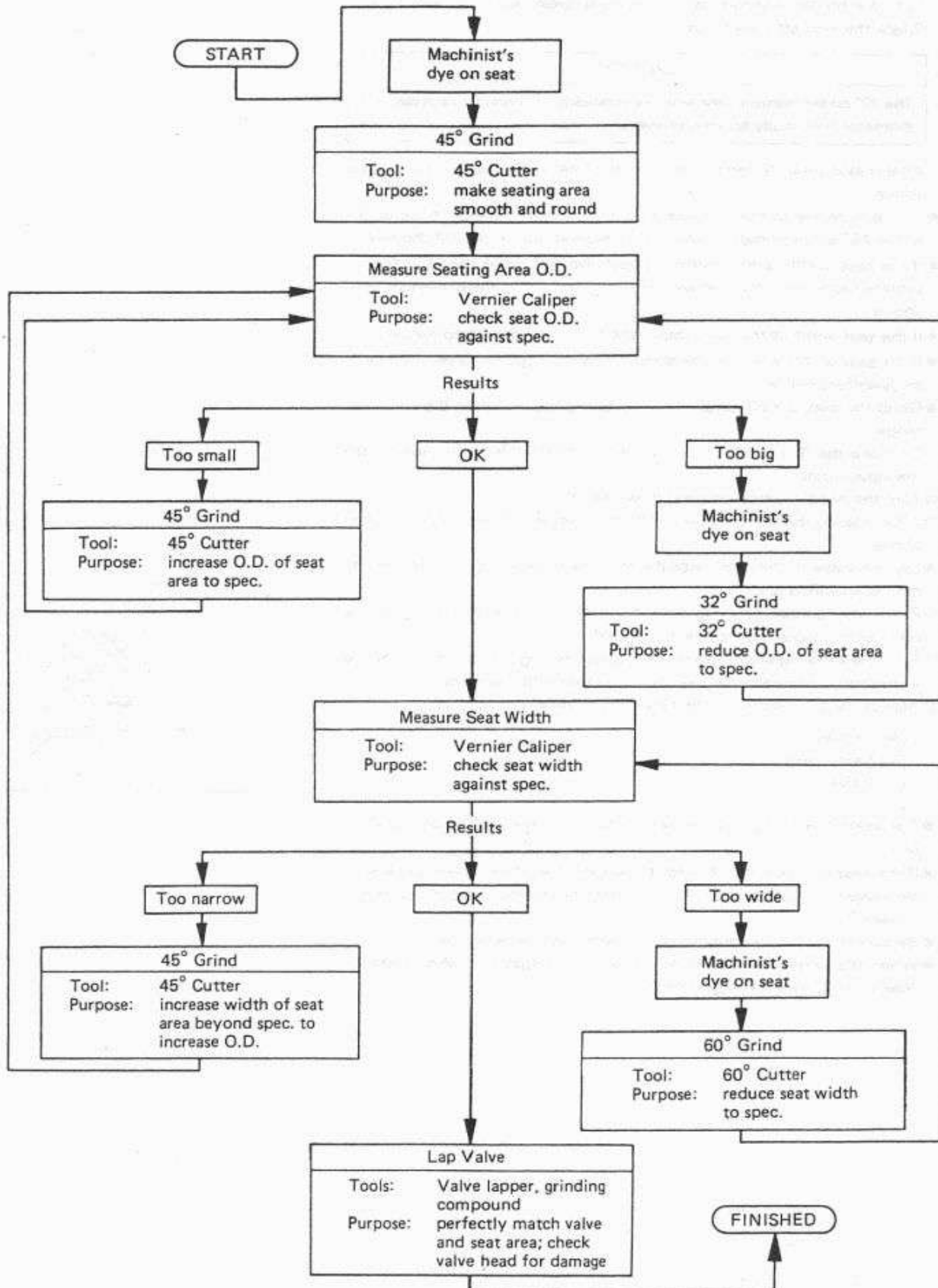

## Cylinder, Pistons

### Cylinder Removal

- Remove:
  - Engine (see Engine Removal/Installation chapter)
  - Cylinder Head (see Cylinder Head Removal)
  - Front Camshaft Chain Guide
  - Water Hose [A]
  - Rear Camshaft Chain Guide [B] and Bolt
- Remove the cylinder.

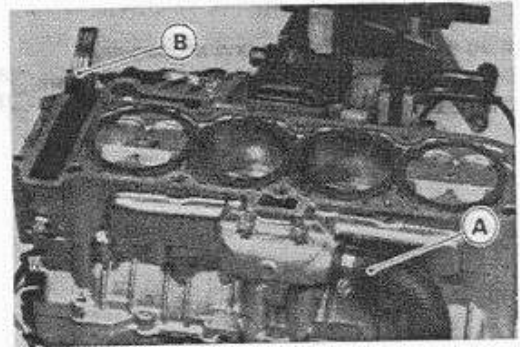

### Cylinder Installation

- Install:
  - New Cylinder Gasket [A]
  - Pins [B]
- Apply engine oil to the cylinder bore.
- Prepare two auxiliary head bolts with their head cut.
- Install the two bolts [C] diagonally in the crankcase.
- Level the pistons.
- Install the cylinder block.

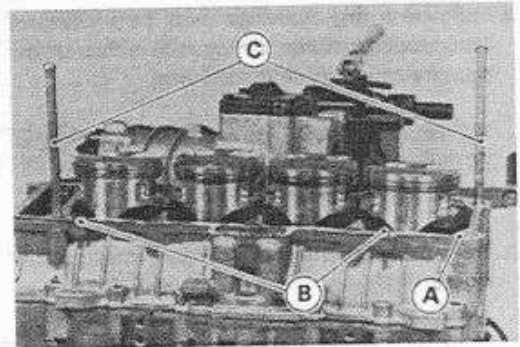

- Install the rear camshaft chain guide [A] and O-ring [B], and tighten the bolt [C].

**Torque – Rear Camshaft Chain Guide Bolt: 25 N-m (2.5 kg-m, 18.0 ft-lb)**

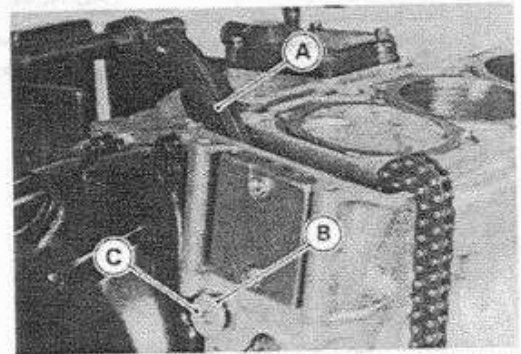

### Piston Removal

- Remove the cylinder (see Cylinder Removal).
- Place a clean cloth under the pistons and remove the piston pin snap ring from the outside of each piston.
- Remove the piston pins.

**Special Tool – Piston Pin Puller Assembly: 57001-910 [A]**

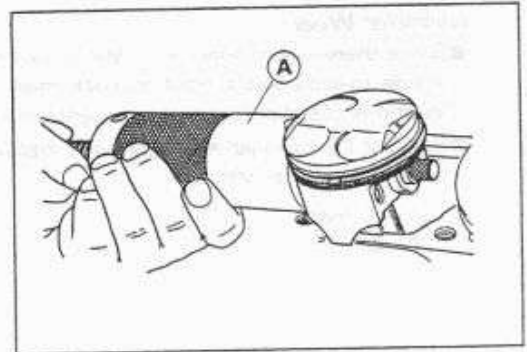

- Carefully spread the ring opening with your thumbs and then push up on the opposite side of the ring [A] to remove it.
- Remove the 3-piece oil ring with your thumbs in the same manner.

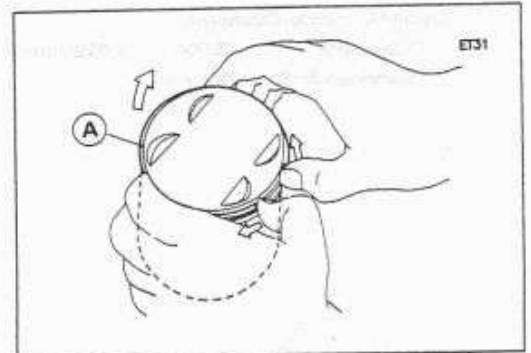

**Piston Installation**

- Do not mix up the top and second ring.
- Install the top ring [A] so that the "R" mark [B] faces up.
- Install the second ring [C] so that the "RN" mark [D] faces up.

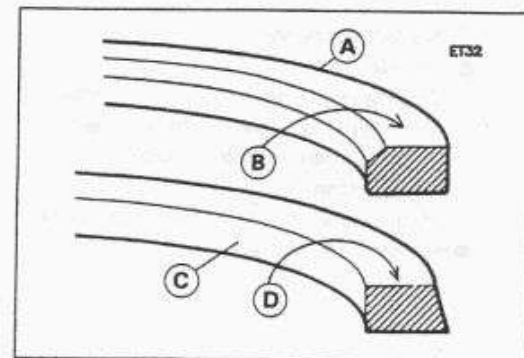

- The piston ring openings must be positioned as shown in the figure. The openings of the oil ring steel rails must be about 30 – 40° of angle from the opening of the top ring.

- [A] Top Ring
- [B] Second Ring
- [C] Oil Ring Steel Rails
- [D] Oil Ring Expander
- [E] Arrow

- The arrow on the piston head must point toward the front of the engine.

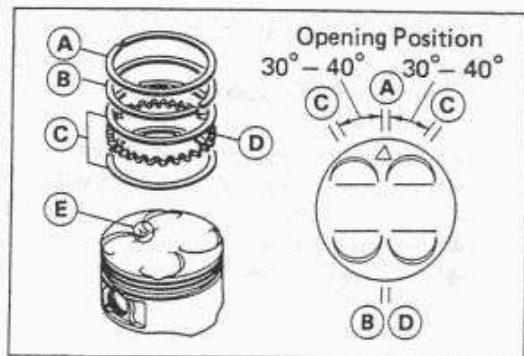

**CAUTION**

Do not reuse snap rings, as removal weakens and deforms them. They could fall out and score the cylinder wall.

**Cylinder Wear**

- Since there is a difference in cylinder wear in different directions, take a side-to-side and a front-to-back measurement at each of the two locations (total of four measurements) shown in the figure.
- ★ If any of the cylinder inside diameter measurements exceeds the service limit, replace the cylinder.

- [A] 10 mm
- [B] 60 mm

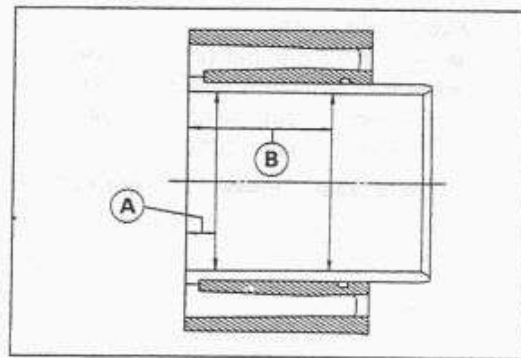

**Cylinder Inside Diameter**

- Standard: 73.000 ~ 73.012 mm
- Service Limit: 73.1 mm



### Piston Wear

- Measure the outside diameter [A] of each piston 5 mm [B] up from the bottom of the piston at a right angle to the direction of the piston pin.

★ If the measurement is under service limit, replace the piston.

#### Piston Diameter

Standard:	72.942 ~ 72.958 mm
Service Limit:	72.8 mm

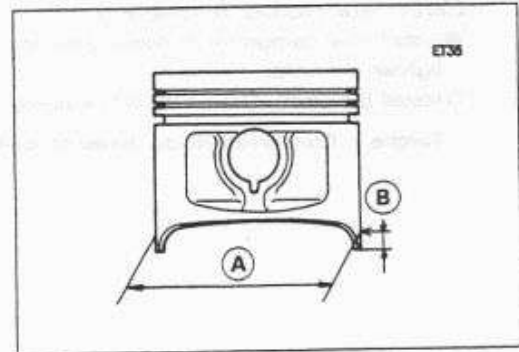

### Piston Ring, Piston Ring Groove Wear

- Check for uneven groove wear by inspecting the ring seating.
- ★ The rings should fit perfectly parallel to groove surfaces. If not, the piston must be replaced.
- With the piston rings in their grooves, make several measurements with a thickness gauge [A] to determine piston ring/groove clearance.

#### Piston Ring/Groove Clearance

	Standard	Service Limit
Top	0.05 ~ 0.09 mm	0.19 mm
Second	0.03 ~ 0.07 mm	0.17 mm

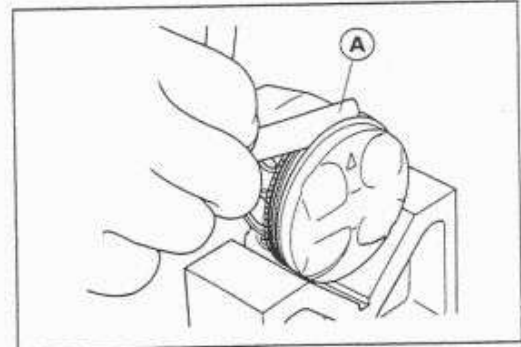

### Piston Ring End Gap

- Place the piston ring [A] inside the cylinder, using the piston to locate the ring squarely in place. Set it close to the bottom of the cylinder, where cylinder wear is low.
- Measure the gap [B] between the ends of the ring with a thickness gauge.

#### Piston Ring End Gap

	Standard	Service Limit
Top	0.20 ~ 0.35 mm	0.65 mm
Second	0.40 ~ 0.55 mm	0.85 mm

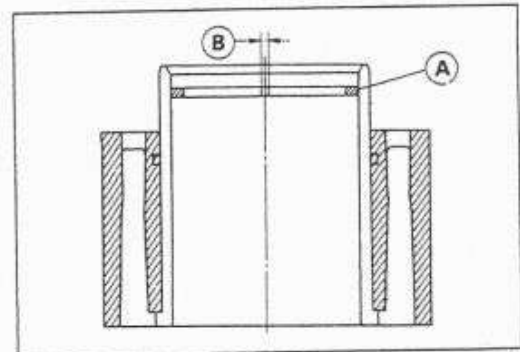

## Carburetor Holder

### Carburetor Holder Installation

- Install the carburetor holders with the holes [A] downward and tighten the bolts.
- Install the clamp [B] on the #2 carburetor holder as shown.

**Torque – Carburetor Holder Bolts: 12 N-m (1.2 kg-m, 104 in-lb)**

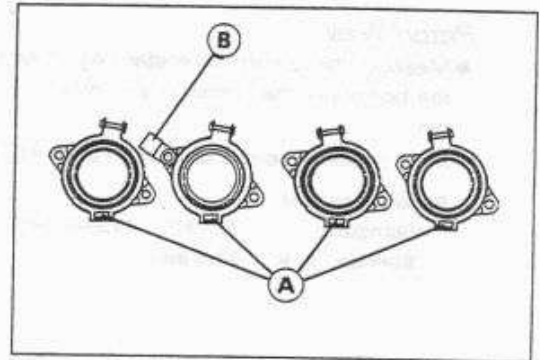

## Muffler

### *Muffler Removal*

- Remove:
  - Coolant (drain, see Cooling System chapter)
  - Radiator (see Cooling System chapter)
  - Muffler Mounting Bolt [A]

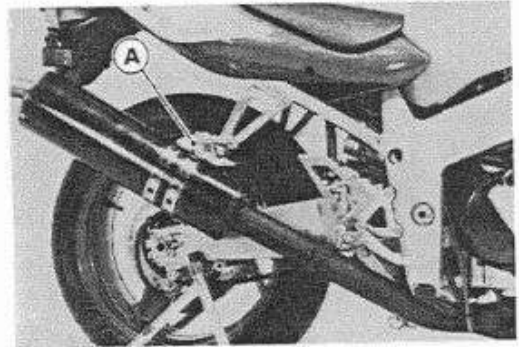

- Holder Nuts [A]
- Exhaust Pipe Holders [B]

- Remove the exhaust pipes [C] and muffler.

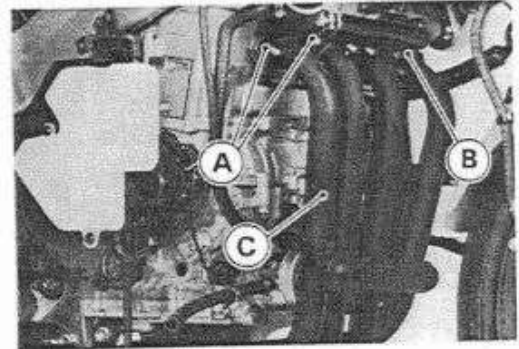

### *Muffler Installation*

- Replace the exhaust pipe gaskets with new ones.

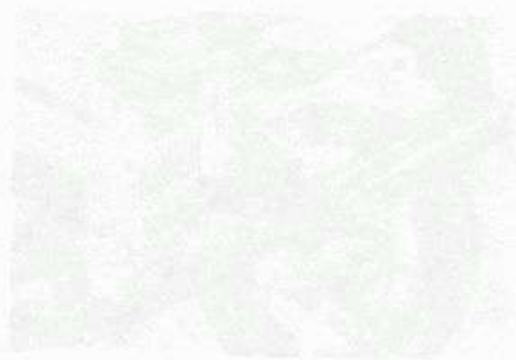

1. The first step is to identify the location of the engine. This is done by looking at the engine's position relative to the other components of the system. The engine is located in the center of the system, and is connected to the other components by a series of pipes and hoses.



2. The second step is to identify the type of engine. This is done by looking at the engine's design and construction. The engine is a diesel engine, and is designed for use in a marine environment. It is a four-cylinder engine, and is capable of producing a maximum power output of 100 horsepower.

3. The third step is to identify the engine's specifications. This is done by looking at the engine's technical data sheet. The engine's specifications include its maximum power output, its maximum torque, and its maximum RPM. The engine's maximum power output is 100 horsepower, its maximum torque is 100 lb-ft, and its maximum RPM is 2000.

# Clutch

## Table of Contents

Exploded View .....	5-2
Specifications .....	5-3
Clutch Fluid .....	5-4
Fluid Level Inspection.....	5-4
Clutch Fluid Change.....	5-4
Bleeding the Clutch Line .....	5-5
Clutch Master Cylinder .....	5-6
Clutch Master Cylinder Removal.....	5-6
Clutch Master Cylinder Installation .....	5-6
Clutch Master Cylinder Disassembly.....	5-6
Clutch Master Cylinder Assembly .....	5-7
Clutch Master Cylinder Inspection (Visual Inspection) .....	5-7
Clutch Slave Cylinder.....	5-8
Clutch Slave Cylinder Removal .....	5-8
Clutch Slave Cylinder Installation .....	5-8
Clutch Slave Cylinder Disassembly .....	5-8
Clutch Slave Cylinder Assembly.....	5-9
Clutch .....	5-10
Clutch Removal .....	5-10
Clutch Installation.....	5-10
Spring Plate Free Play Measurement.....	5-13
Spring Plate Free Play Adjustment .....	5-14
Clutch Plate, Wear, Damage Inspection .....	5-15
Clutch Plate Warp Inspection.....	5-15
Clutch Spring Free Length Measurement.....	5-15
Damper Cam Inspection.....	5-15

# 5-2 CLUTCH

## Exploded View

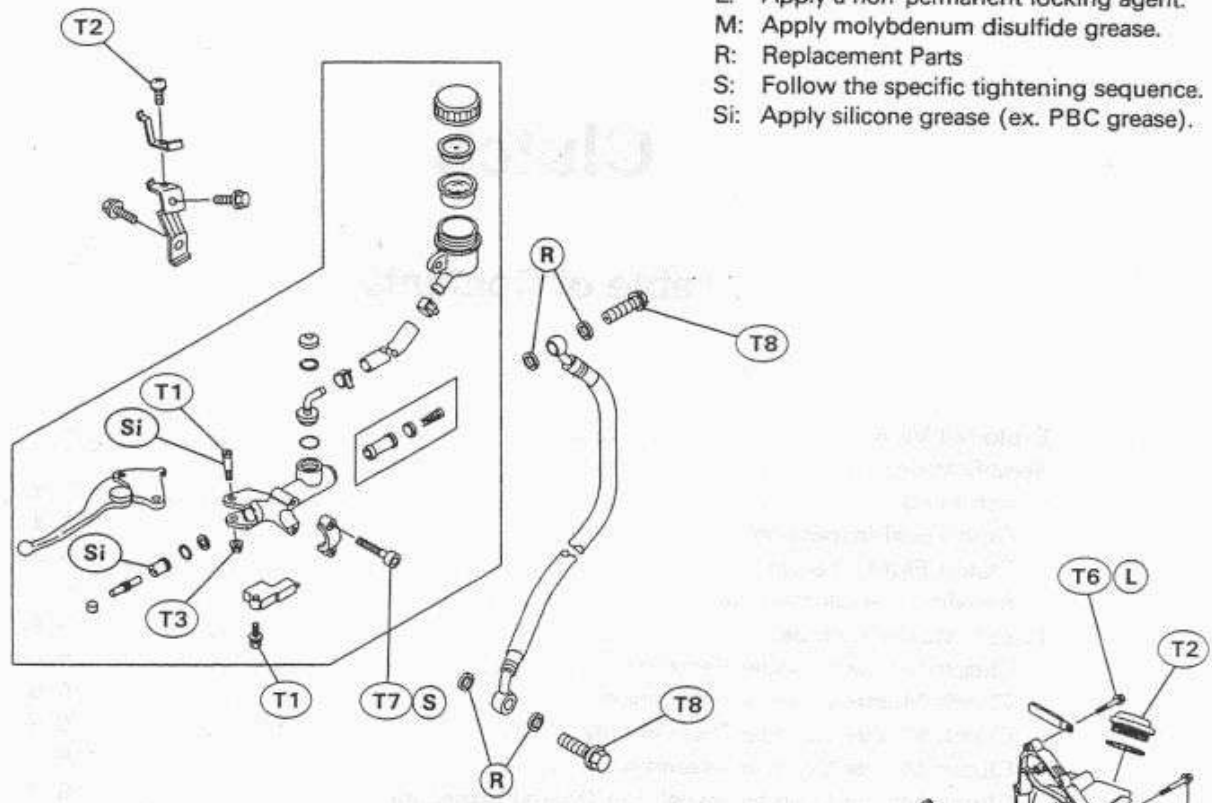

EO: Apply engine oil.  
 L: Apply a non-permanent locking agent.  
 M: Apply molybdenum disulfide grease.  
 R: Replacement Parts  
 S: Follow the specific tightening sequence.  
 Si: Apply silicone grease (ex. PBC grease).

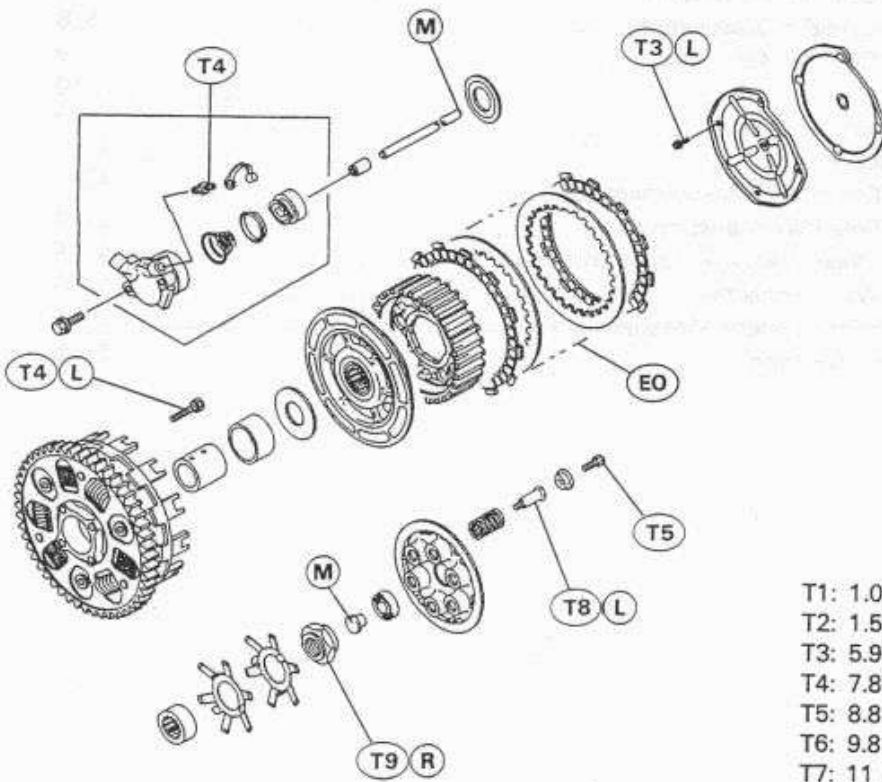

- T1: 1.0 N-m (0.10 kg-m, 9 in-lb)
- T2: 1.5 N-m (0.15 kg-m, 13 in-lb)
- T3: 5.9 N-m (0.60 kg-m, 52 in-lb)
- T4: 7.8 N-m (0.80 kg-m, 69 in-lb)
- T5: 8.8 N-m (0.90 kg-m, 78 in-lb)
- T6: 9.8 N-m (1.0 kg-m, 87 in-lb)
- T7: 11 N-m (1.1 kg-m, 95 in-lb)
- T8: 25 N-m (2.5 kg-m, 18.0 ft-lb)
- T9: 130 N-m (13.5 kg-m, 98 ft-lb)

## Specifications

Item	Standard	Service Limit
<b>Recommended Clutch Fluid:</b> Grade Brand	D.O.T.4 Castrol Girling-Universal Castrol GT (LMA) Castrol Disc Brake Fluid Check Shock Premium Heavy Duty	--- --- --- --- ---
<b>Clutch Lever Position</b>	4-way adjustable (to suit rider)	---
<b>Clutch Lever Free Play</b>	Non-adjustable	---
<b>Clutch:</b> Spring plate free play (new plates) Spring plate free play (no new plates) Friction and steel plate warp Clutch spring free length: ZX750N ZX750P	0.05 ~ 0.35 mm (Usable range) 0.15 ~ 0.75 mm (Usable range) 0.2 mm or less 42.9 mm 34.7 mm	--- --- 0.3 mm 40.9 mm 33.5 mm

**Special Tool – Inside Circlip Pliers: 57001-143**  
**Clutch Holder: 57001-1243**

**Sealant – Kawasaki Bond (Silicone Sealant): 56019-120**

## Clutch Fluid

*Fluid Level Inspection*

- Check the clutch fluid level in the reservoir.
  - Lower Level Line [A]
  - Upper Level Line [B]

**NOTE**

- Hold the reservoir horizontal when checking clutch fluid level.
- ★ If the fluid level is lower than the lower level line, fill the reservoir to the upper level line in the reservoir.

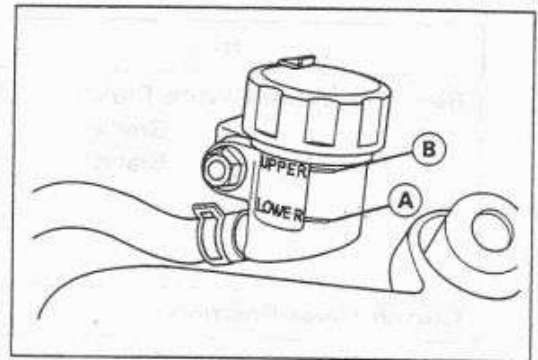
**⚠ WARNING**

Change the fluid in the clutch line completely if the fluid must be refilled but the type and brand of the fluid that already is in the reservoir are unidentified.

After changing the fluid, use only the same type and brand of fluid thereafter. Mixing different types and brands of fluid lowers the fluid boiling point and could cause the clutch to be ineffective. It may also cause the rubber clutch parts to deteriorate.

**Recommended Clutch Fluid**

- Grade: D.O.T.4
- Brand: Castrol Girling-Universal
- Castrol GT (LMA)
- Castrol Disc Brake Fluid
- Check Shock Premium Heavy Duty

**NOTE**

- Since the clutch fluid is the same as the brake fluid, refer to Brake Fluid Section in Brakes chapter for further details.

*Clutch Fluid Change*

- Level the clutch fluid reservoir.
- Remove the reservoir cap.
- Remove the rubber cap from the bleed valve on the clutch slave cylinder.
- Attach a clear plastic hose to the bleed valve and run the other end of the hose into a container.
- Fill the reservoir with fresh fluid.
- Change the clutch fluid as follows:
  - Open the bleed valve. [A]
  - Squeeze the clutch lever and hold it. [B]
  - Close the bleed valve. [C]
  - Release the clutch lever. [D]
- Repeat this operation until fresh fluid comes out from the plastic hose or the color of the fluid changes.
- Check the fluid level in the reservoir often, replenishing it as necessary.

**NOTE**

- If the fluid in the reservoir runs completely out any time during fluid changing, the bleeding operation must be done since air will have entered the line.

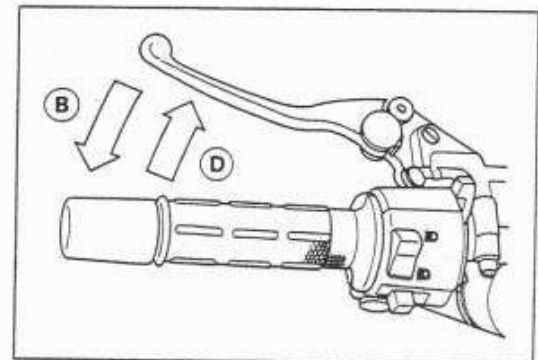
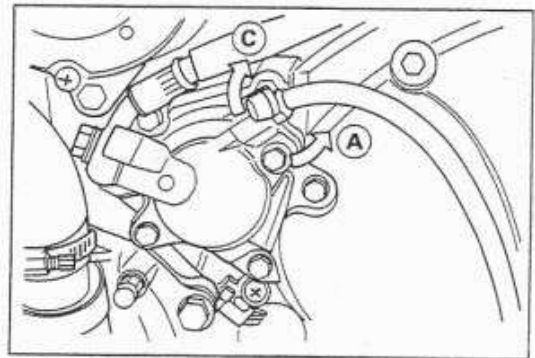



### Bleeding the Clutch Line

- With the reservoir cap off, slowly pump the clutch lever several times until no air bubbles can be seen rising up through the fluid from the holes at the bottom of the reservoir. This bleeds the air from the master cylinder end of the line.

#### NOTE

- Tap the clutch hose lightly going from the lower end to the upper end and bleed the air off at the reservoir.
- Attach a clear plastic hose to the bleed valve on the clutch slave cylinder, and run the other end of the hose into a container.

- Bleed the clutch line as follows:

- Pump the clutch lever a few times until it becomes hard and then hold it squeezed. [A]
- Quickly open and close the bleed valve. [B]
- Release the clutch lever. [C]
- Repeat this operation until no more air can be seen coming out in to the plastic hose.
- Check the fluid level in the reservoir often, replenishing it as necessary.

#### NOTE

- If the fluid in the reservoir runs completely out any time during bleeding, the bleeding operation must be done over again from the beginning since air will have entered the line.

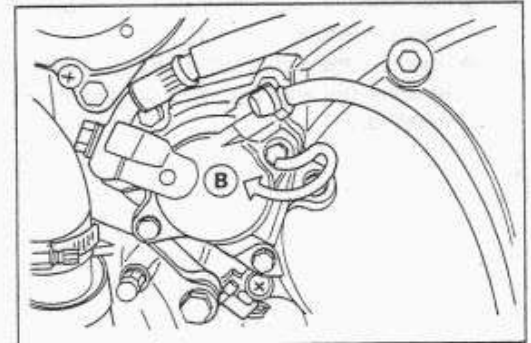
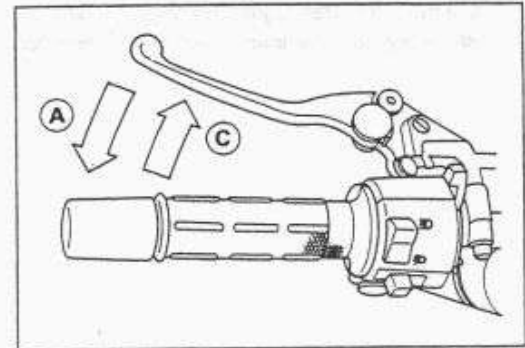

## Clutch Master Cylinder

### Clutch Master Cylinder Removal

- Disconnect the starter lockout switch connector [A].

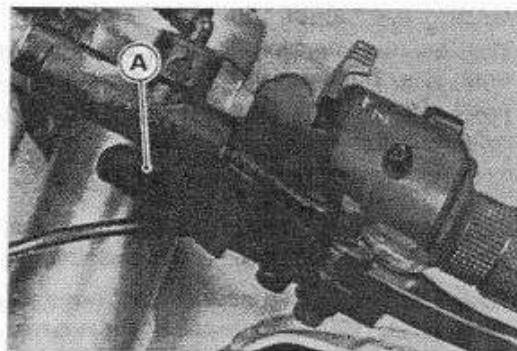

- Remove the banjo bolt [A] to disconnect the clutch hose from the master cylinder.
- Unscrew the clamp bolts [B], and take off the master cylinder [C] as an assembly with the reservoir, clutch lever, and starter lockout switch installed.

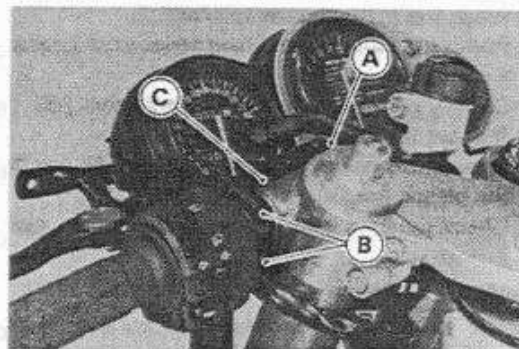

### Clutch Master Cylinder Installation

- Align the punch mark [A] on the handlebar with the mating surface [B] of the master cylinder clamp.
- The master cylinder clamp must be installed with the arrow mark upward.
- Tighten the upper clamp bolt first, and then the lower clamp bolt. There will be a gap at the lower part of the clamp after tightening.

**Torque – Clutch Master Cylinder Clamp Bolts: 11 N-m (1.1 kg-m, 95 in-lb)**

- Replace the washers that are on each side of the hose fitting with new ones.
- Tighten the clutch hose banjo bolt.

**Torque – Clutch Hose Banjo Bolt: 25 N-m (2.5 kg-m, 18.0 ft-lb)**

- Bleed the clutch line (see Bleeding the Clutch Line).

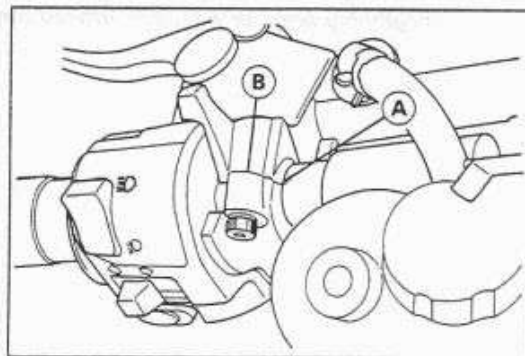

### Clutch Master Cylinder Disassembly

- Remove the master cylinder.
- Remove the reservoir cap and diaphragm, and pour the clutch fluid into a container.
- Unscrew the locknut and pivot bolt, and remove the clutch lever.
- Push the dust cover out of place, and remove the circlip.

**Special Tool – Inside Circlip Pliers: 57001-143**

- Pull out the piston [A], secondary cup [B], primary cup [C], and return spring [D].

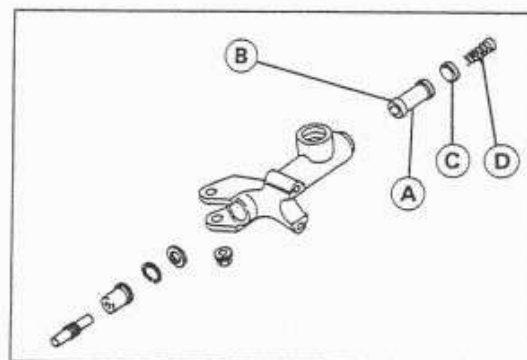

**CAUTION**

Do not remove the secondary cup from the piston since removal will damage it.

**Clutch Master Cylinder Assembly**

- Before assembly, clean all parts including the master cylinder with clutch fluid or alcohol.

**CAUTION**

Use only disc brake/clutch fluid, isopropyl alcohol, or ethyl alcohol, for cleaning parts. Do not use any other fluid for cleaning these parts. Gasoline, motor oil, or any other petroleum distillate will cause deterioration of the rubber parts. Oil spilled on any part will be difficult to wash off completely, and will eventually deteriorate the rubber used in the cylinder.

- Apply clutch fluid to the parts removed and to the inner wall of the cylinder. Take care not to scratch the piston or the inner wall of the cylinder.
- Check to see that the piston return spring pushes back the piston to its rest position when the spring is compressed.
- Install the push rod with the dust seal fitted into the groove.
- The push rod round end must be faced inwards.
- Use a new flat washer on each side of the hose fitting.
- Tighten the banjo bolt.

**Torque – Clutch Hose Banjo Bolt: 25 N-m (2.5 kg-m, 18.0 ft-lb)**

- Fill the clutch fluid into the clutch line and bleed the clutch line (see Clutch Fluid Change and Bleeding the Clutch Line).

**Clutch Master Cylinder Inspection (Visual Inspection)**

- Check that there are no scratches, rust or pitting on the inside of the master cylinder and on the outside of the piston.
- ★ If the master cylinder or piston shows any damage, replace them.
- Inspect the primary cup and secondary cup.
- ★ If a cup is worn, damaged, softened (rotted), or swollen, the piston assembly should be replaced to renew the cups.
- If fluid leakage is noted at the clutch lever, the piston assembly should be replaced to renew the cups.
- Check the dust cover for damage.
- If it is damaged, replace it.
- Check that the relief and supply ports are not plugged.
- ★ If the small relief port becomes plugged, the clutch will slip. Blow the ports clean with compressed air.
- Check the piston return spring for any damage.
- ★ If the spring is damaged, replace it.

## Clutch Slave Cylinder

### Clutch Slave Cylinder Removal

- Remove:
  - Left Lower Fairing (see Frame chapter)
  - Banjo Bolt [A]
  - Mounting Bolts [B]
  - Slave Cylinder [C]

#### CAUTION

Immediately wash away any clutch fluid that spills. It may damage painted surfaces.

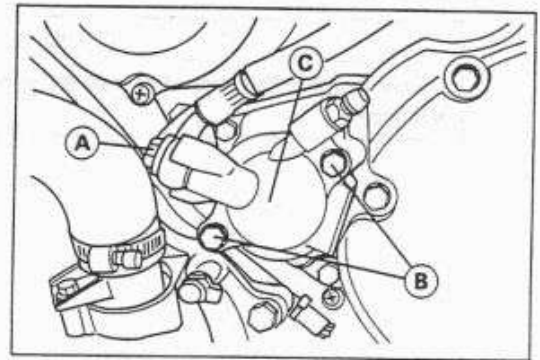

- Perform the following if the clutch slave cylinder is to be removed but not disassembled.

#### CAUTION

If the clutch slave cylinder is removed and left alone, the piston will be pushed out by the spring and the clutch fluid will drain out.

- Remove the clutch slave cylinder from the engine with the hose and push the piston into the cylinder as far as it will go.
- Squeeze the clutch lever slowly and hold it with a band.

#### NOTE

- Holding the clutch lever keeps the piston from coming out.

### Clutch Slave Cylinder Installation

- Replace the washers on each side of the clutch hose fitting with new ones.
  - Tighten the banjo bolt.
- Torque – Clutch Hose Banjo Bolt: 25 N-m (2.5 kg-m, 18.0 ft-lb)**
- Check the fluid level in the master cylinder reservoir, and bleed the air in the clutch line.
  - Check the clutch operation.

### Clutch Slave Cylinder Disassembly

- Using compressed air [A], remove the piston.
- Cover the cylinder opening with a clean, heavy cloth [B].
- Face the opening downwards.
- Remove the piston by lightly applying compressed air to where the clutch line fits into the slave cylinder.

#### CAUTION

If the fluid seal is removed from the piston, replace the seal with a new one. Removal would damage the seal.

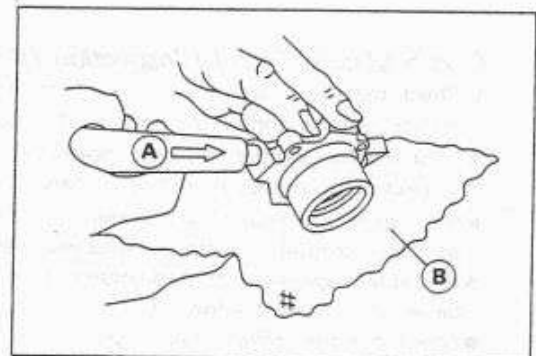

#### ⚠ WARNING

To avoid serious injury, never place your fingers or palm in front of the cylinder opening. If you apply high compressed air to the cylinder, the piston may injure your hand or fingers.

**Clutch Slave Cylinder Assembly**

- Apply clutch fluid to the outside of the piston and the fluid seal.
- Install the fluid seal as shown in the figure.

- [A] Cylinder
- [B] Piston
- [C] Fluid Seal
- [D] Spring

**CAUTION**

Replace the fluid seal with a new one if it was removed from the piston.

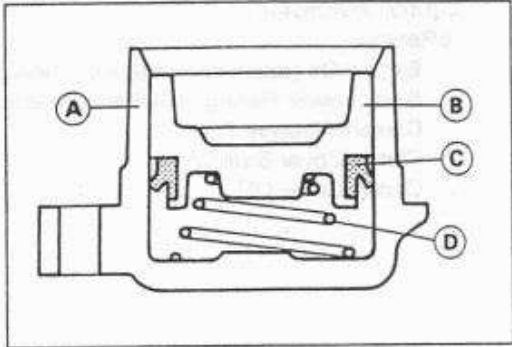

## 5-10 CLUTCH

### Clutch

#### Clutch Removal

● Remove:

- Engine Oil (drain, see Engine Lubrication System chapter)
- Right Lower Fairing (see Frame chapter)
- Coolant Reserve Tank
- Clutch Cover Bolts [A]
- Clutch Cover [B]

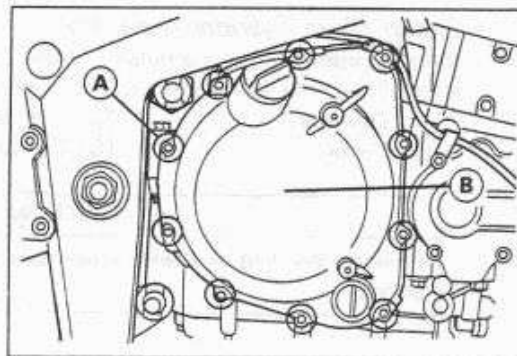

- Clutch Spring Bolts [A]
- Clutch Springs
- Clutch Spring Plate [B]

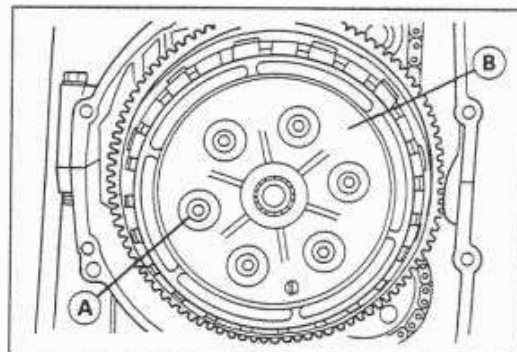

- Friction Plates, Steel Plates
- Clutch Hub Nut [A]

○ Holding the sub clutch hub [B], remove the nut.

**Special Tool – Clutch Holder: 57001-1243 [C]**

● Remove:

- Torque Limiter Springs [D]
- Sub Clutch Hub
- Toothed Washer
- Clutch Hub [E]

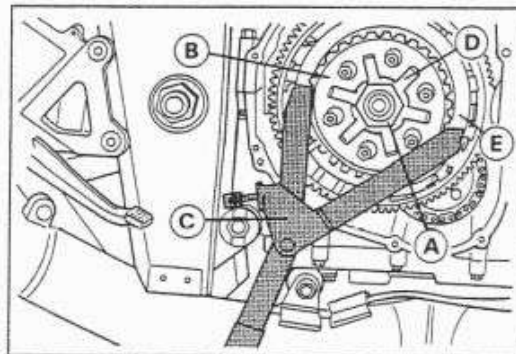

- Spacer [A]
- Clutch Housing
- Bolts [B]
- Clutch Housing [C] and Needle Bearing

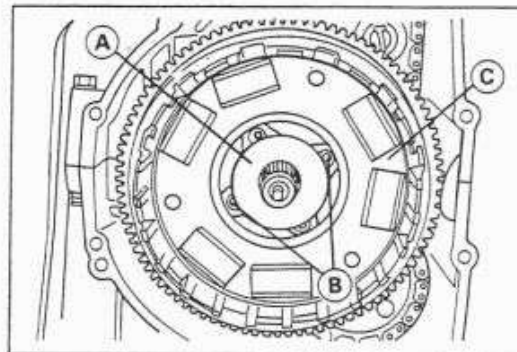

#### Clutch Installation

● When replacing any one of the following parts, adjust the spring plate free play (see Spring Plate Free Play Measurement).

- Clutch Spring Plate
- Friction Plate
- Steel Plate

- Fit the pins [A] of the drive gear [B] into the holes [C] in the clutch housing [D], and install the needle bearing.

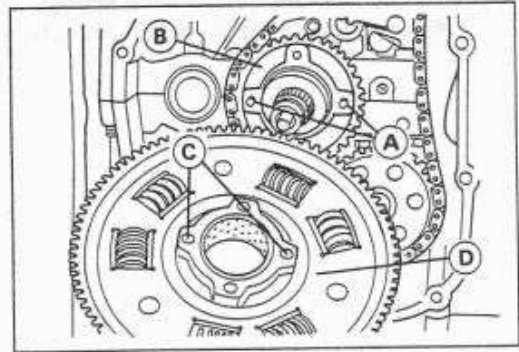

- ★ If the housing [A] is hard to install, turn the timing rotor [B].

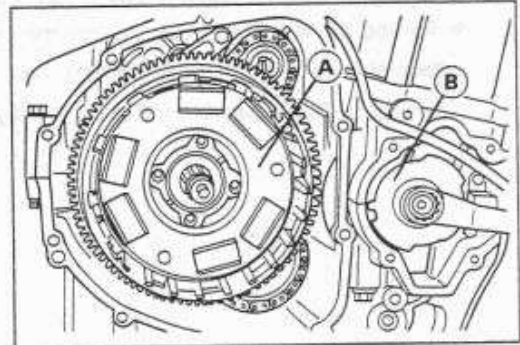

- Apply a non-permanent locking agent to the threads of the housing bolts [A] and tighten them.

**Torque – Clutch Housing Bolts: 7.8 N-m (0.80 kg-m, 69 in-lb)**

- Install the spacer [B].

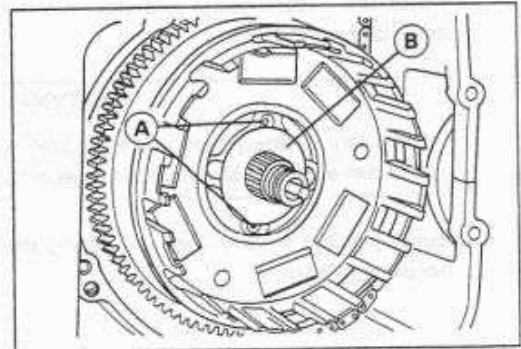

- Install the clutch hub [A].
- Install the toothed washer [B] so that the groove side [C] faces inward.

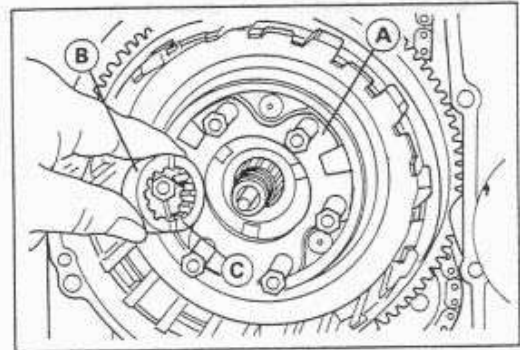

- Engage the cam followers [A] (Clutch Hub) with the cams [B] (Sub Clutch Hub).

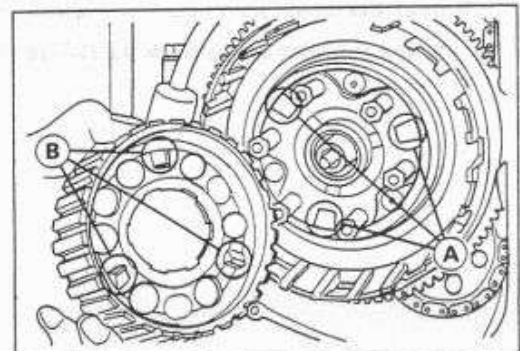

- Pile up the two torque limiter springs [A] so that their shift angle of 60°, and then fit the spring tongues [B] in the sub clutch hub [C].

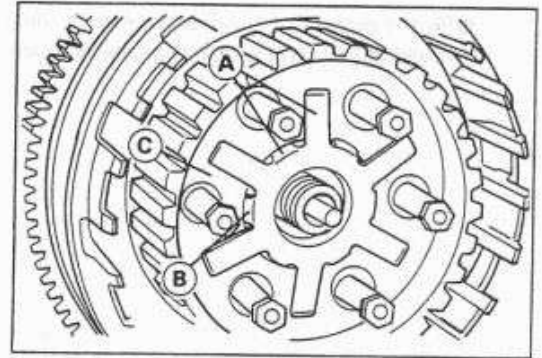

- Replace the clutch hub nut with a new one.
- Holding the sub clutch hub, tighten the clutch hub nut.

**Special Tool – Clutch Holder: 57001-1243**

**Torque – Clutch Hub Nut: 130 N-m (13.5 kg-m, 98 ft-lb)**

- Install the friction plates and steel plates, starting with a friction plate and alternating them.

**CAUTION**

**If new dry friction plates and steel plates are installed, apply engine oil to the surfaces of each plate to avoid clutch plate seizure.**

- Install the last friction plate [A] fitting the tangs in the grooves in the housing as shown.

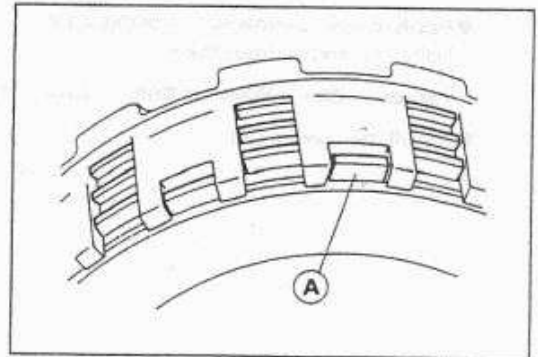

- Apply molybdenum disulfide grease [A] to the push rod [B] and pusher [C] end.

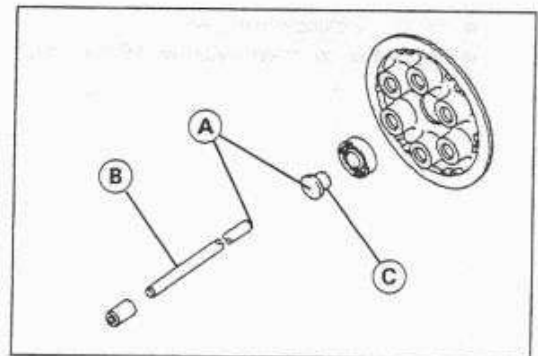

- Install the clutch spring plate and tighten the clutch spring bolts.

**Torque – Clutch Spring Bolts: 8.8 N-m (0.90 kg-m, 78 In-lb)**



- Replace the cover gasket with a new one.
- Apply silicone sealant to the area [A] where the mating surface of the crankcase touches the clutch cover gasket.

Sealant – Kawasaki Bond (Silicone Sealant): 56019-120

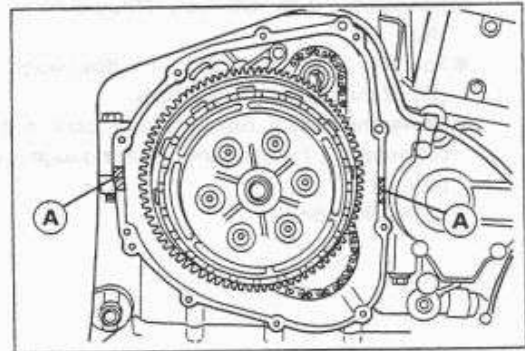

- Install the clutch cover [A].
- Apply a non-permanent locking agent to the threads of the two clutch cover bolts [B].
- Tighten the clutch cover bolts.

Torque – Clutch Cover Bolts: 9.8 N-m (1.0 kg-m, 87 in-lb)

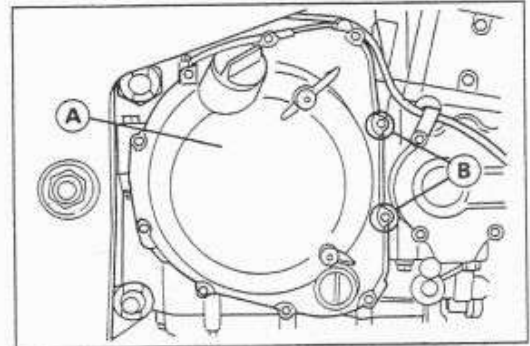

### Spring Plate Free Play Measurement

Insufficient clutch free play will cause the engine braking effect to be more sudden, resulting in rear wheel hop. On the other hand, if the free play is excessive, the clutch lever may feel "spongy" or pulsate when pulled.

- Remove oil from the clutch plates.
- Hold an extra drive shaft in a vise and install the following clutch parts on the shaft.

- [A] Spacers
- [B] Needle Bearings
- [C] Drive Sprocket
- [D] Clutch Housing
- [E] Bolts
- [F] Collar
- [G] Clutch Hub
- [H] Sub Clutch Hub
- [I] Friction and Steel Plates
- [J] Spring Plate

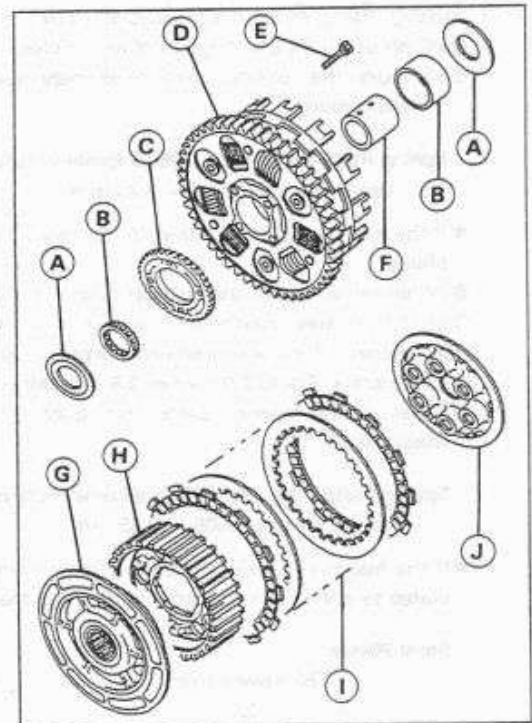

- Engage the cam followers (Clutch Hub) with the cams (Sub Clutch Hub).
  - To measure the free play, set a dial gauge [A] against the raised center [B] of the clutch spring plate.
  - Move the clutch housing gear back and forth [C]. The difference between the highest and lowest gauge readings is the amount of free play.
- [D] Drive Shaft

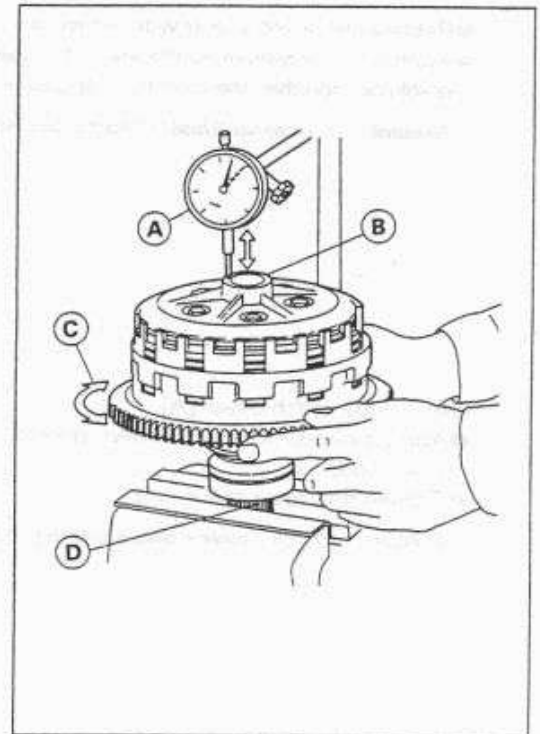

### Spring Plate Free Play Adjustment

- When using all the original clutch plates, do the following.
  - Measure the spring plate free play (see Spring Plate Free Play Measurement).

#### Spring Plate Free Play (With original friction plates)

Usable range: 0.15 ~ 0.75 mm

- ★ If the free play is not within the usable range, change all of the friction plates.

- When replacing all the friction plates, do the following.
  - Install the steel plates and all the new friction plates in the housing temporarily for measurement purpose (Standard Steel Plate: **2.3 mm thickness** × 6 and **2.0 mm or 2.6 mm thickness** × 1).
  - Measure the spring plate free play (see Spring Plate Free Play Measurement).

#### Spring Plate Free Play (With all new friction plates)

Usable range: 0.05 ~ 0.35 mm

- ★ If the free play is not within the usable range, change one of the steel plates to a thicker or thinner one to get the correct free play.

#### Steel Plates

Thickness (mm)	Part Number
2.0	13089-026
2.3	13089-1004
2.6	13089-1067

**Clutch Plate, Wear, Damage Inspection**

- Visually inspect the friction and steel plates for signs of seizure, overheating (discoloration), or uneven wear.
- ★ If any plates show signs of damage, replace them with new ones.

**Clutch Plate Warp Inspection**

- Place each friction plate or steel plate on a surface plate and measure the gap between the surface plate [A] and each friction plate or steel plate [B] with a thickness gauge [C]. The gap is the amount of friction or steel plate warp.
- ★ If any plate is warped over the service limit, replace it with a new one.

**Friction and Steel Plate Warp**

Standard:	0.2 mm or less
Service Limit:	0.3 mm

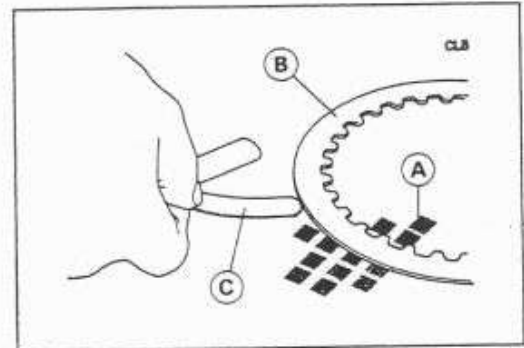
**Clutch Spring Free Length Measurement**

- Measure the free length of the clutch springs [A].
- ★ If any spring is shorter than the service limit, it must be replaced.

**Clutch Spring Free Length****ZX750N**

Standard:	42.9 mm
Service Limit:	40.9 mm

**ZX750P**

Standard:	34.7 mm
Service Limit:	33.5 mm

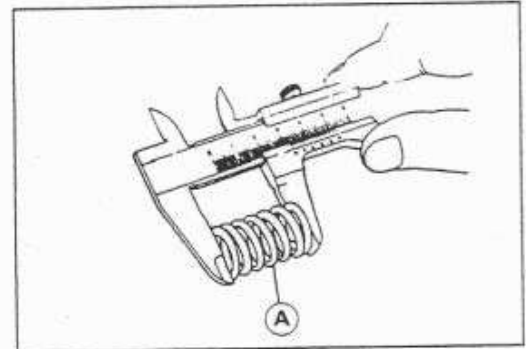
**Damper Cam Inspection**

- Remove the clutch (see Clutch Removal).
- Visually inspect the damper cam [A], cam follower [B], and the torque limiter spring [C].
- Replace the part if it appears damaged.

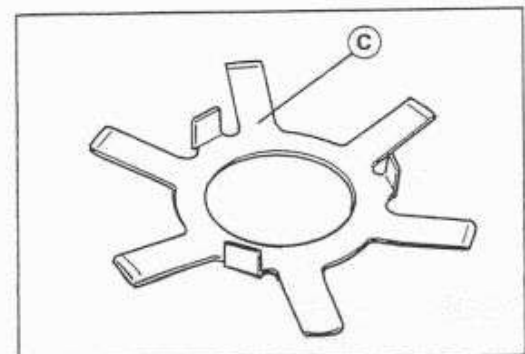
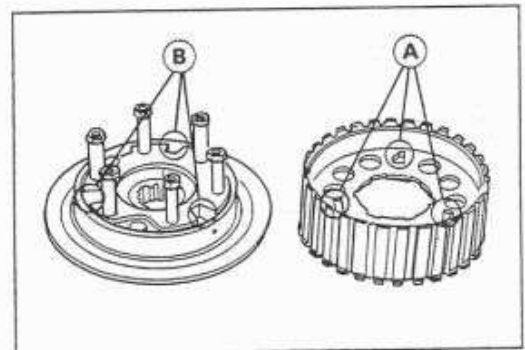

Class 6-8: Water Damage in walls. This class covers the basic and advanced techniques for water damage restoration. It includes a detailed overview of the water damage process and how to identify and prevent it.



Water damage in walls is a common problem that can lead to mold and structural damage. This class covers the basic and advanced techniques for water damage restoration. It includes a detailed overview of the water damage process and how to identify and prevent it.



Water damage in walls is a common problem that can lead to mold and structural damage. This class covers the basic and advanced techniques for water damage restoration. It includes a detailed overview of the water damage process and how to identify and prevent it.



Water damage in walls is a common problem that can lead to mold and structural damage. This class covers the basic and advanced techniques for water damage restoration. It includes a detailed overview of the water damage process and how to identify and prevent it.



Water damage in walls is a common problem that can lead to mold and structural damage. This class covers the basic and advanced techniques for water damage restoration. It includes a detailed overview of the water damage process and how to identify and prevent it.

# Engine Lubrication System

## Table of Contents

Exploded View .....	6-2
Engine Oil Flow Chart.....	6-3
Specifications .....	6-4
Engine Oil and Oil Filter.....	6-5
Oil Level Inspection .....	6-5
Engine Oil Change.....	6-5
Oil Filter Change .....	6-6
Oil Cooler.....	6-7
Oil Cooler Removal.....	6-7
Oil Cooler Installation .....	6-7
Oil Pan .....	6-8
Oil Pan Removal .....	6-8
Oil Pan Installation.....	6-8
Oil Pump.....	6-9
Oil Pump Removal .....	6-9
Oil Pump Installation .....	6-9
Oil Pressure Measurement.....	6-10
Oil Pressure Measurement.....	6-10
Relief Valve.....	6-11
Relief Valve Inspection .....	6-11

# 6-2 ENGINE LUBRICATION SYSTEM

## Exploded View

- EO: Apply engine oil.
- L: Apply a non-permanent locking agent.
- R: Replacement Parts
- SS: Apply silicone sealant.
- G: Apply grease.

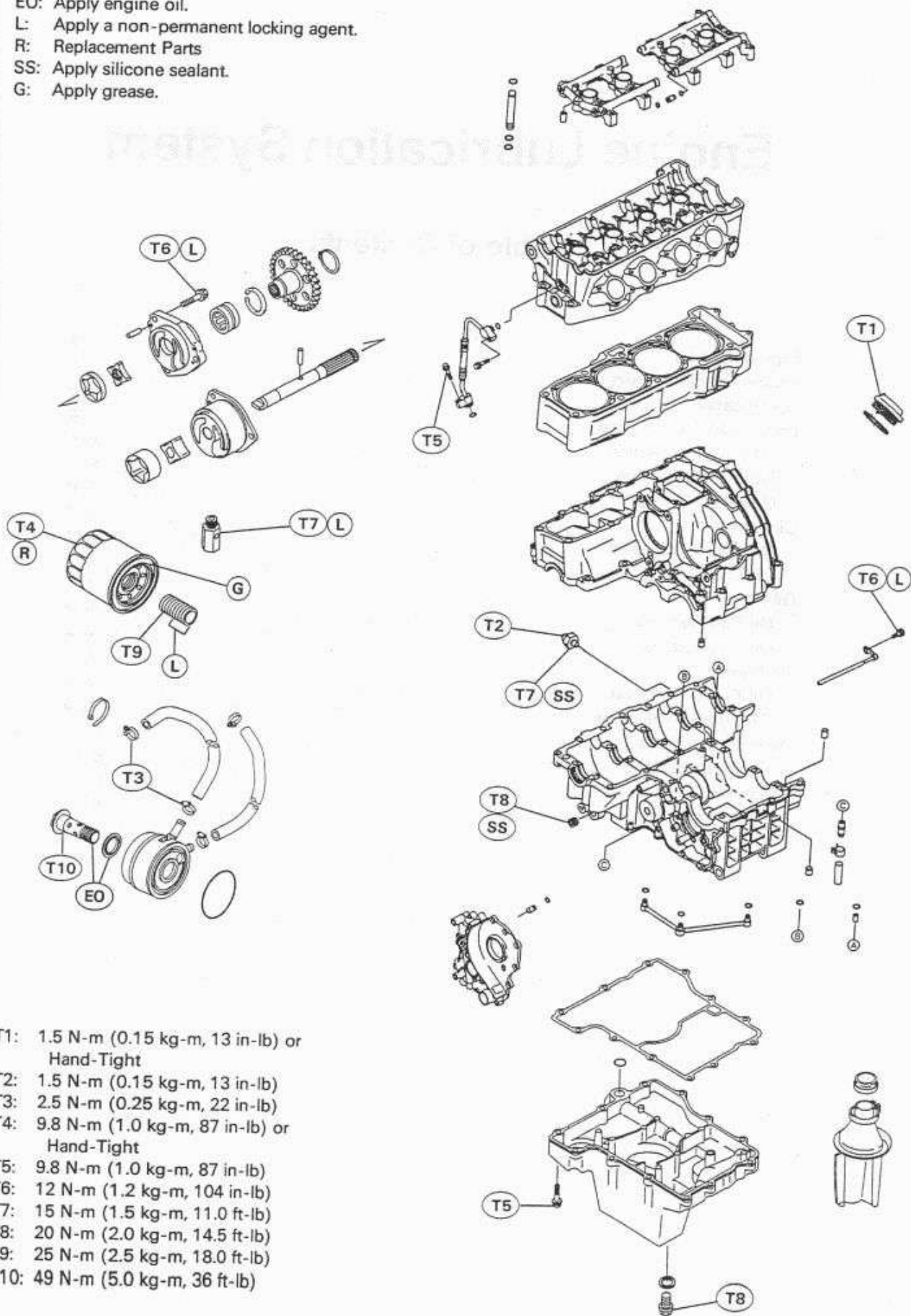

Engine Oil Flow Chart

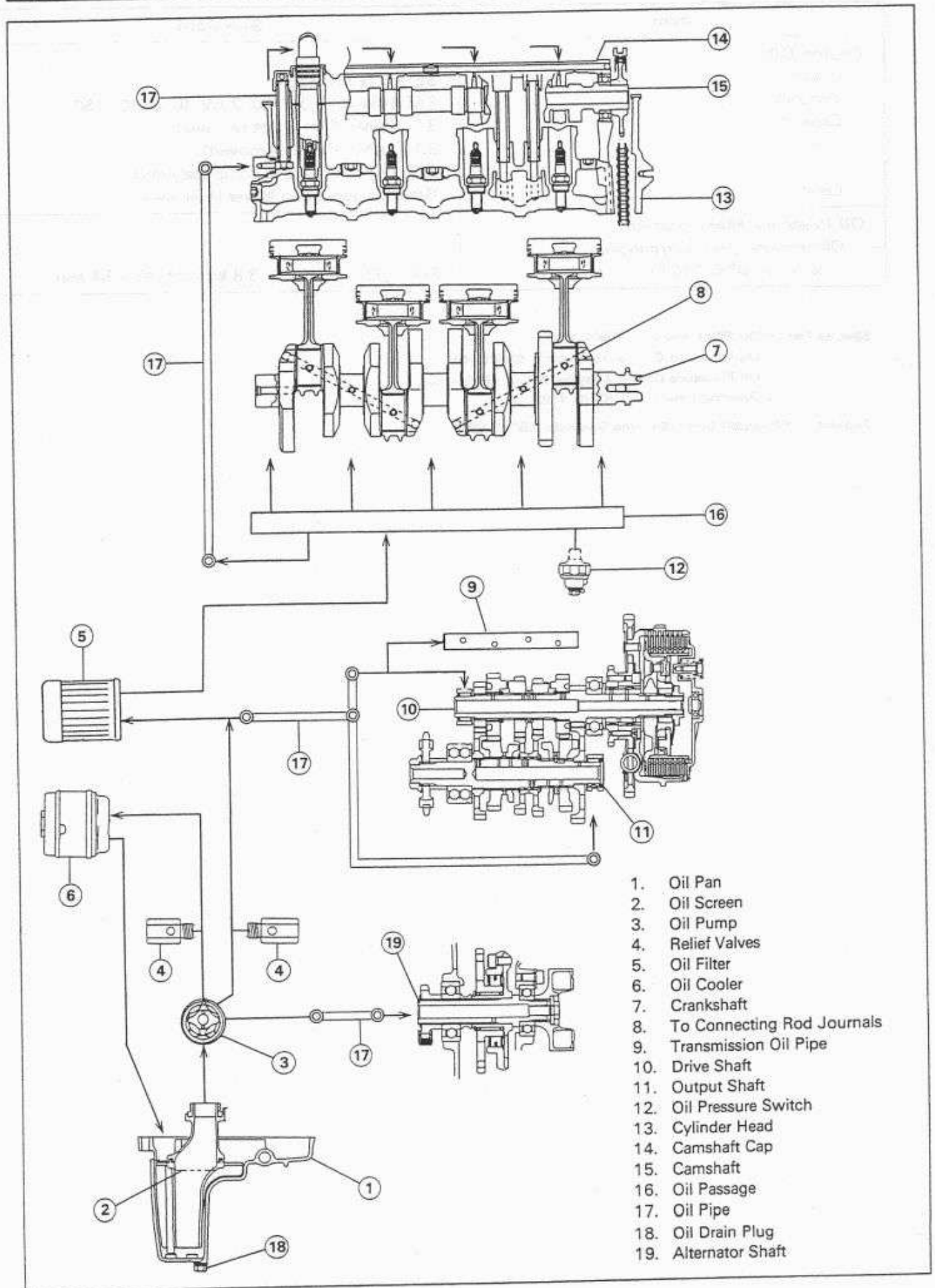

## 6-4 ENGINE LUBRICATION SYSTEM

### Specifications

Item	Standard
<b>Engine Oil:</b> Grade Viscosity Capacity  Level	SE, SF, or SG class SAE 10W-40, 10W-50, 20W-40, or 20W-50 3.0L (when filter is not removed) 3.1L (when filter is removed) 3.6L (when engine is completely dry) Between upper and lower level lines
<b>Oil Pressure Measurement:</b> Oil pressure @4,000 r/min(rpm), oil temp. 80°C(176°F)	314 ~ 373 kPa(3.2 ~ 3.8 kg/cm <sup>2</sup> , 46 ~ 54 psi)

**Special Tool – Oil Filter Wrench: 57001-1249**

**Oil Pressure Gauge, 10 kg/cm<sup>2</sup>: 57001-164**

**Oil Pressure Gauge Adapter, PT 1/8": 57001-1033**

**Bearing Driver Set: 57001-1129**

**Sealant – Kawasaki Bond (Silicone Sealant): 56019-120**



## Engine Oil and Oil Filter

**WARNING**

Motorcycle operation with insufficient, deteriorated, or contaminated engine oil will cause accelerated wear and may result in engine or transmission seizure, accident, and injury.

*Oil Level Inspection*

- Check that the engine oil level is between the upper [A] and lower [B] levels in the gauge.

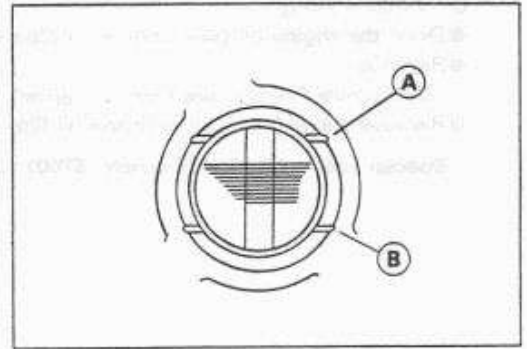
**NOTE**

- Situate the motorcycle so that it is perpendicular to the ground.
- If the motorcycle has just been used, wait several minutes for all the oil to drain down.
- If the oil has just been changed, start the engine and run it for several minutes at idle speed. This fills the oil filter with oil. Stop the engine, then wait several minutes until the oil settles.

**CAUTION**

Racing the engine before the oil reaches every part can cause engine seizure.

If the engine oil gets extremely low or if the oil pump or oil passages clog up or otherwise do not function properly, the oil pressure warning light will light. If this light stays on when the engine is running above idle speed, stop the engine immediately and find the cause.

*Engine Oil Change*

- Support the motorcycle perpendicular to the ground after warming up the engine.
  - Remove the engine drain plug [A] to drain the oil.
  - The oil in the oil filter can be drained by removing the filter (see Oil Filter Change).
  - ★ Replace the drain plug gasket with a new one if it is damaged.
  - Tighten the drain plug.
- Torque – Engine Drain Plug: 20 N-m (2.0 kg-m, 14.5 ft-lb)**
- Pour in the specified type and amount of oil.

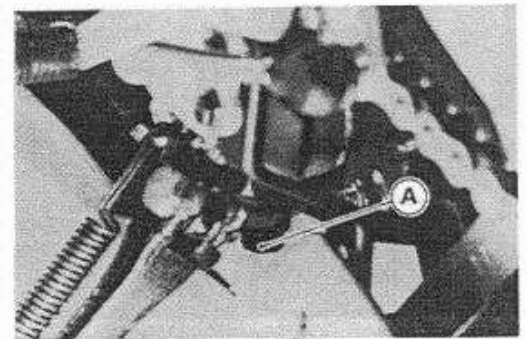
**Engine Oil**

- Grade:** SE, SF or SG class
- Viscosity:** SAE 10W40, 10W50, 20W40, or 20W50
- Amount:** 3.0 L (when filter is not removed)  
3.1 L (when filter is removed)  
3.6 L (when engine is completely dry)

### Oil Filter Change

- Drain the engine oil (see Engine Oil Change).
- Remove:
  - Left Lower Fairing (see Frame chapter)
- Remove the oil filter [A] with the oil filter wrench [B].

**Special Tool – Oil Filter Wrench: 57001-1249**

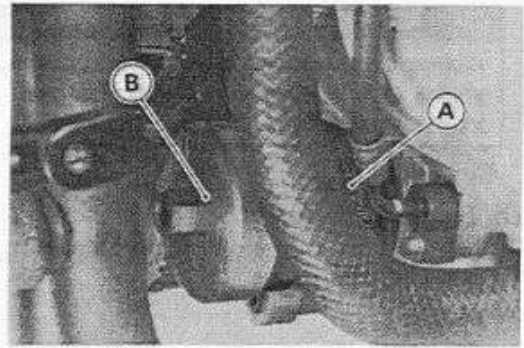

- Replace the filter with a new one.
- Apply grease to the gasket [A] before installation.
- Tighten the filter with the oil filter wrench or with hands about  $\frac{3}{4}$  turns after the gasket contacts the mounting surface of the engine.

**Torque – Oil Filter: 9.8 N-m (1.0 kg-m, 87 in-lb) or Hand-tight**

- Pour in the specified type and amount of oil (see Engine Oil Change).

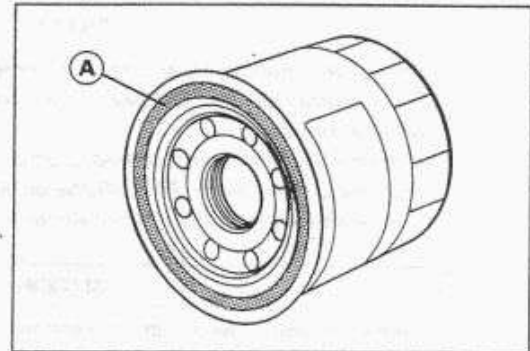

## Oil Cooler

### Oil Cooler Removal

- Drain:
  - Engine Oil (see Engine Oil Change)
  - Coolant (see Cooling System chapter)
- Remove the oil cooler hoses [A] from the oil cooler [B].

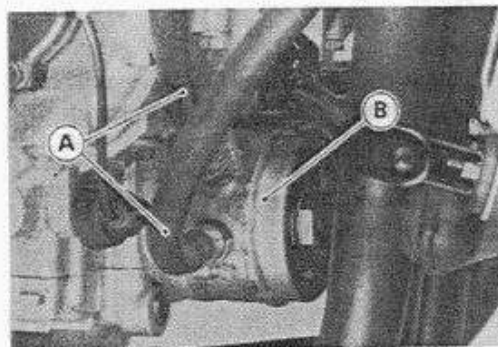

- Unscrew the oil cooler bolt [A] from the crankcase.

### NOTE

- Do not remove the bolt from the oil cooler body.
- Move the front part of the oil cooler and bolt to the right.

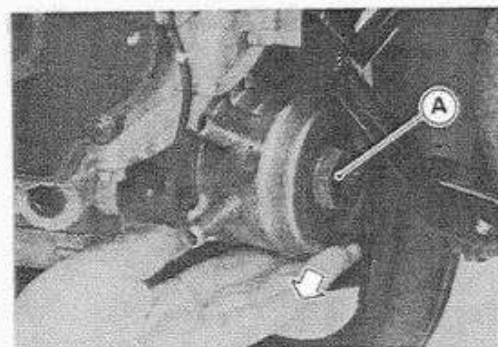

- Remove the oil cooler with the oil cooler bolt.

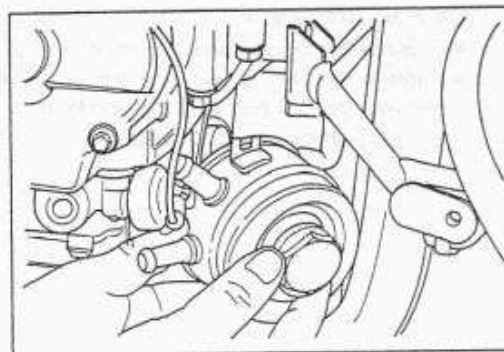

### Oil Cooler Installation

- Installation is the reverse of removal. Note the following.
- Apply grease to the O-ring [A] before installation.
- Apply engine oil to the oil cooler bolt, and install the oil cooler with the bolt.

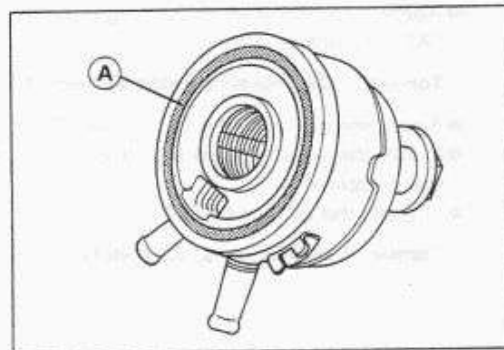

- Install the oil cooler so that the crankcase rib [A] fits the slot [B] of the oil cooler.
- Tighten the oil cooler bolt.

**Torque – Oil Cooler Bolt: 49 N-m (5.0 kg-m, 36 ft-lb)**

- Pour:
  - Engine Oil (see Engine Oil Change)
  - Coolant (see Cooling System chapter)

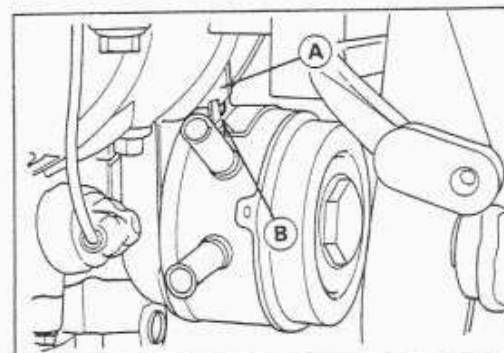

## Oil Pan

### Oil Pan Removal

- Drain:
  - Engine Oil (see Engine Oil Change)
  - Coolant (see Cooling System chapter)
- Remove:
  - Radiator (see Cooling System chapter)
  - Muffler (see Engine Top End chapter)
  - Oil Pan Bolts [A]
  - Oil Pan [B]

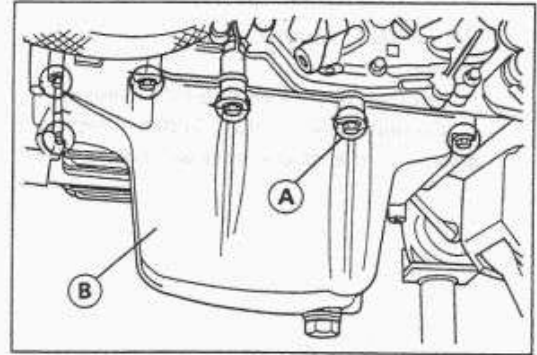

- Remove the oil pipe [A], oil pressure relief valves [B] and oil screen [C] as necessary.

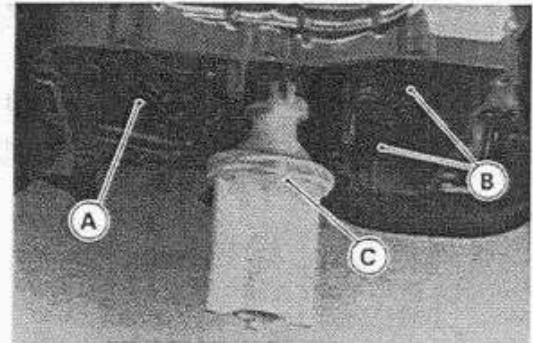

### Oil Pan Installation

- Replace the oil pan gasket with a new one.
- Replace the O-ring [A] with a new one if it is damaged. The O-ring between the oil pan and the crankcase must be installed with the flat side [B] facing the crankcase.

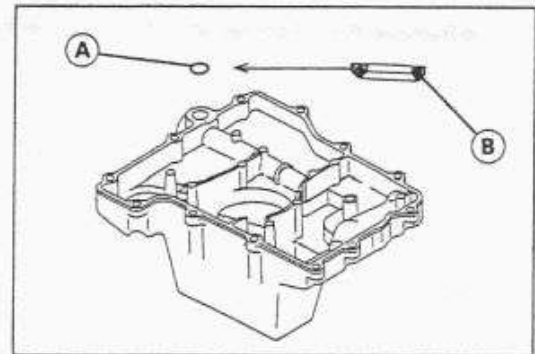

- Apply a non-permanent locking agent to the threads of the relief valves [A], and tighten them.

**Torque – Oil Pressure Relief Valves: 15 N-m (1.5 kg-m, 11.0 ft-lb)**

- Apply engine oil to the O-rings on the oil pipes.
- Install the oil screen so that the crankcase rib [B] fits the slot [C] of the oil screen.
- Tighten the oil pan bolts.

**Torque – Oil Pan Bolts: 9.8 N-m (1.0 kg-m, 87 in-lb)**

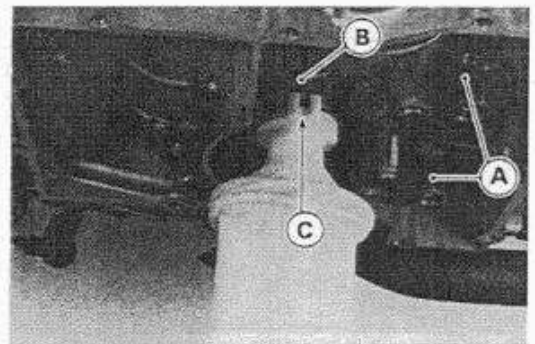

## Oil Pump

### Oil Pump Removal

- Drain the engine oil (see Engine Oil Change)
- Remove:
  - Right Lower Fairing (see Frame chapter)
  - Clutch (see Clutch chapter)
  - Alternator Chain (see Crankshaft/Transmission)
  - Oil Pump Bolts [A]
  - Oil Pump Assembly [B]

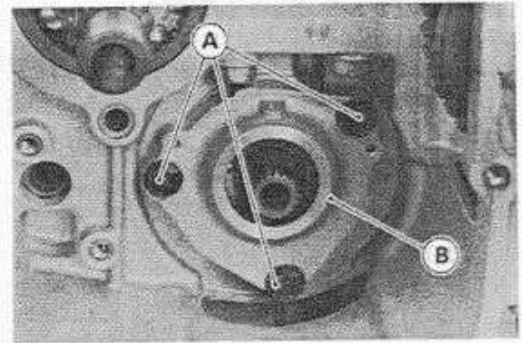

### Oil Pump Installation

- When pressing the needle bearing [A] into the pump cover [B], align the  $\phi 2.5$  mm hole [C] in the bearing with the  $\phi 3.0$  mm hole [D] in the cover.

**Special Tool – Bearing Driver Set: 57001-1129**

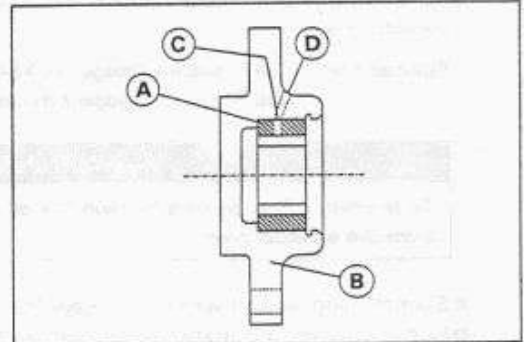

- Install the main rotor [A] and the pump body [B] onto the pump shaft [C].
- Install the pin [D] into the pin hole [E].

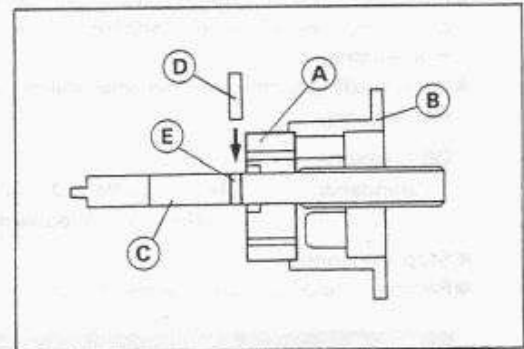

- Install the subrotor [A] so that the mark [B] on the subrotor aligns with the pin [C].

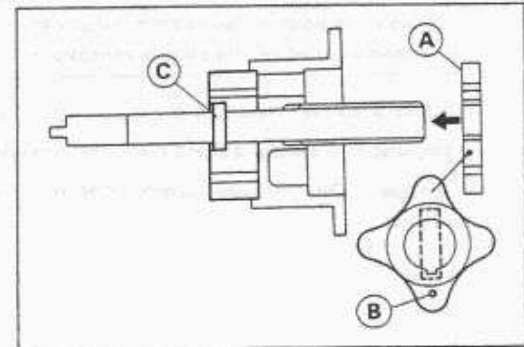

- Be sure to install the pin [A].
- Turn the oil pump shaft so that the pump shaft projection [B] fits the slot [C] in the end of the water pump shaft.
- Install the pump cover.
- Apply a non-permanent locking agent to the threads of the oil pump bolts, and tighten them.

**Torque – Oil Pump Bolts: 12 N-m (1.2 kg-m, 104 in-lb)**

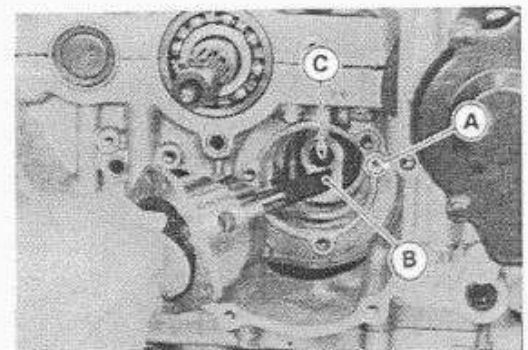

## 6-10 ENGINE LUBRICATION SYSTEM

### Oil Pressure Measurement

#### Oil Pressure Measurement

- Remove:
  - Right Lower Fairing (see Frame chapter)
  - Oil Pressure Switch [A]

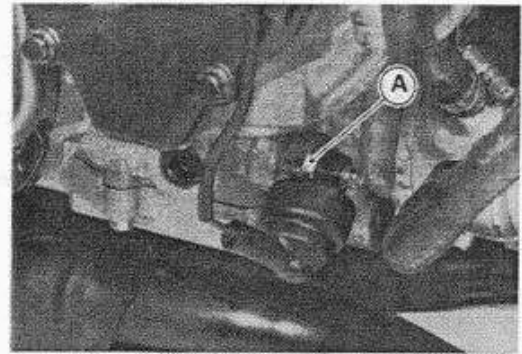

- Attach the oil pressure gauge [A] and adapter [B] to the oil pressure switch hole.

**Special Tool – Oil Pressure Gauge, 10 kg/cm<sup>2</sup>: 57001-164**  
**Oil Pressure Gauge Adapter, PT 1/8: 57001-1033**

#### ⚠ WARNING

To prevent a fire, be sure to keep the oil pressure gauge hose away from the exhaust pipe.

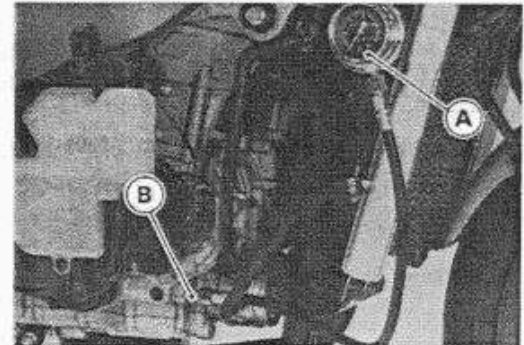

- Start the engine and warm up the engine.
- Run the engine at the specified speed, and read the oil pressure gauge.
- ★ If the oil pressure is much lower than the standard, check the oil pump, oil pump relief valve, and/or crankshaft bearing insert wear immediately.
- ★ If the reading is much higher than the standard, check the oil passages for clogging.

#### Oil Pressure

**Standard: 314 ~ 373 kPa (3.2 ~ 3.8 kg/cm<sup>2</sup>, 46 ~ 54 psi @4000 r/min (rpm), oil temp. 80°C (176°F)**

- Stop the engine.
- Remove the oil pressure gauge and adapter.

#### ⚠ WARNING

Take care against burns from hot engine oil that will drain through the oil passage when the plug is removed.

- Apply silicone sealant to the oil pressure switch, and tighten it.

**Sealant – Kawasaki Bond (Silicone Sealant): 56019-120**

**Torque – Oil Pressure Switch: 15 N-m (1.5 kg-m, 11.0 ft-lb)**

## Relief Valve

### Relief Valve Inspection

- Remove the relief valve (see Oil Pan Removal).
- Check to see if the valve [A] slides smoothly when pushing it in with a wooden or other soft rod, and see if it comes back to its seat by spring [B] pressure.

### NOTE

○ Inspect the valve in its assembled state. Disassembly and assembly may change the valve performance.

- ★ If any rough spots are found during above inspection, wash the valve clean with a high-flash point solvent and blow out any foreign particles that may be in the valve with compressed air.

### ⚠WARNING

Clean the relief valve in a well-ventilated area, and take care that there is no spark or flame anywhere near the working area. Because of the danger of highly flammable liquids, do not use gasoline or low-flash point solvent.

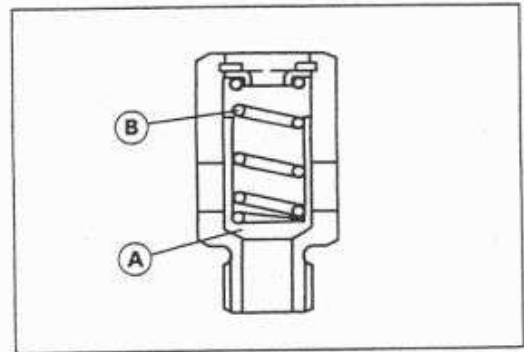

- ★ If cleaning does not solve the problem, replace the relief valve as an assembly. The relief valve is precision made with no allowance for replacement of individual parts.

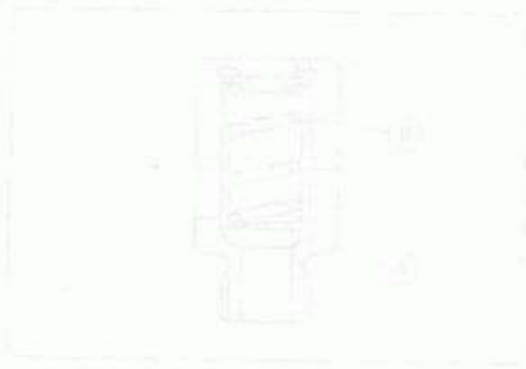

When the piston is at the top of the cylinder, the crankshaft is at the bottom. The piston rings are designed to scrape excess oil from the cylinder walls and return it to the oil pan. The piston rings also help to seal the combustion chamber from the crankcase.

**NOTE**

The piston rings are designed to scrape excess oil from the cylinder walls and return it to the oil pan. The piston rings also help to seal the combustion chamber from the crankcase.

The piston rings are designed to scrape excess oil from the cylinder walls and return it to the oil pan. The piston rings also help to seal the combustion chamber from the crankcase.

The piston rings are designed to scrape excess oil from the cylinder walls and return it to the oil pan. The piston rings also help to seal the combustion chamber from the crankcase.



# Engine Removal / Installation

## Table of Contents

Exploded View .....	7-2
Specifications .....	7-3
Engine Removal/Installation .....	7-4
Engine Removal .....	7-4
Engine Installation .....	7-5

## 7-2 ENGINE REMOVAL / INSTALLATION

### Exploded View

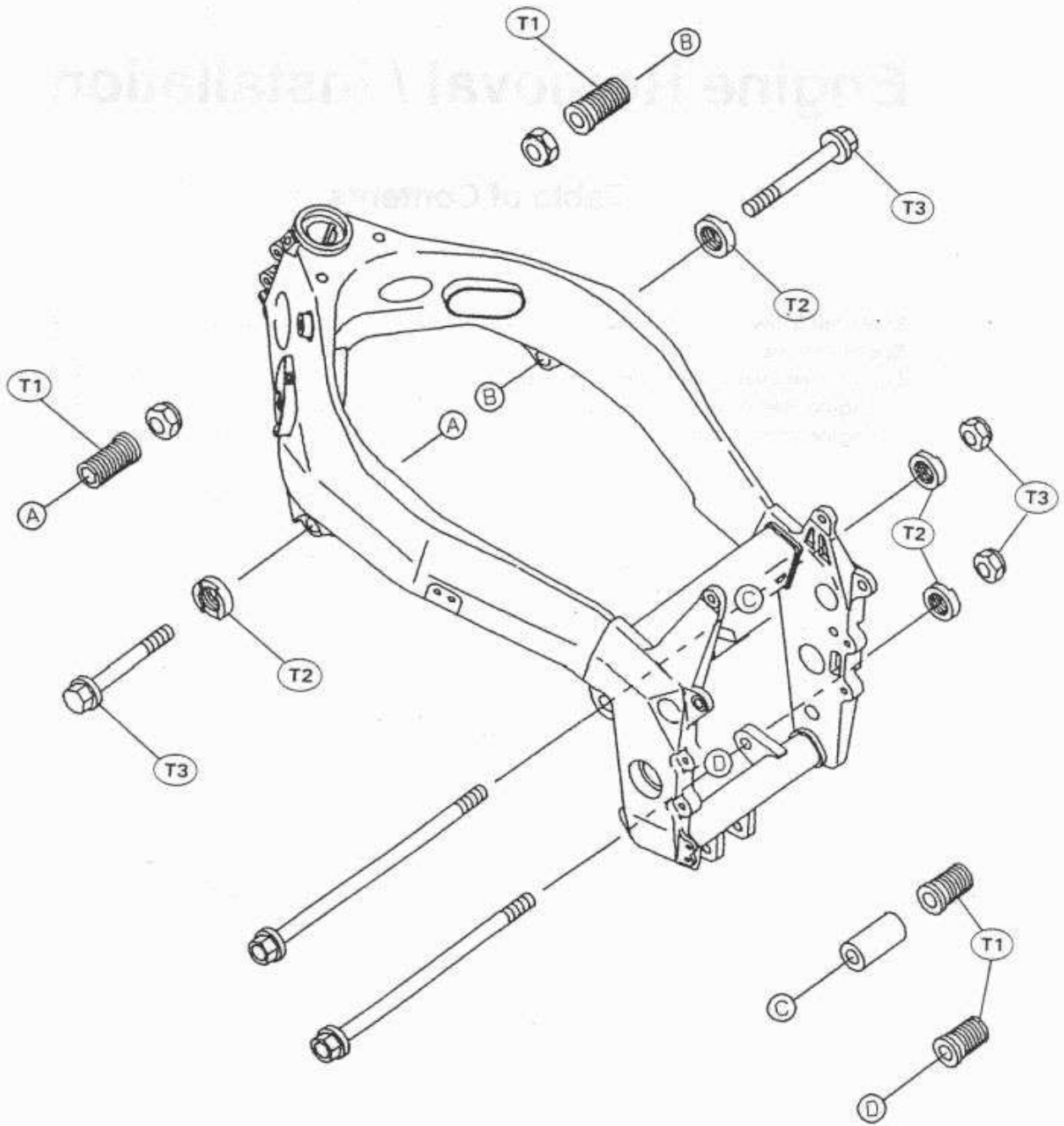

T1: 9.8 N-m (1.0 kg-m, 87 in-lb)  
T2: 49 N-m (5.0 kg-m, 36 ft-lb)  
T3: 59 N-m (6.0 kg-m, 43 ft-lb)

Specifications

Special Tool – Jack: 57001-1238  
Socket Wrench: 57001-1347

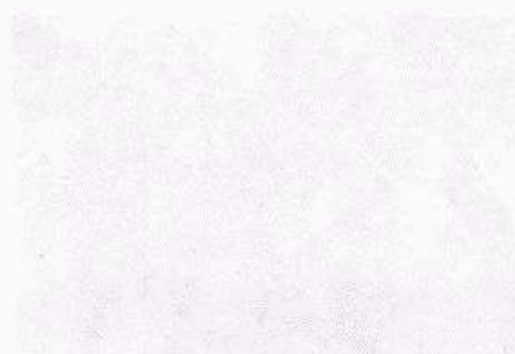
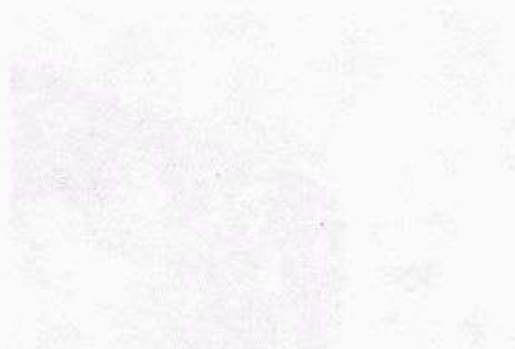
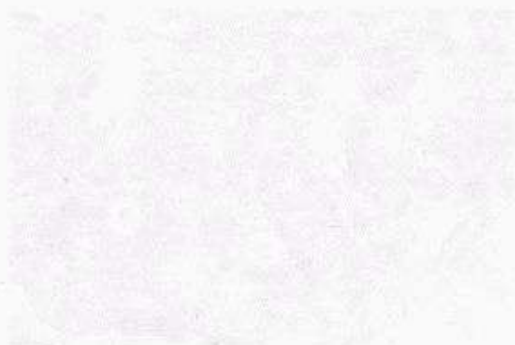
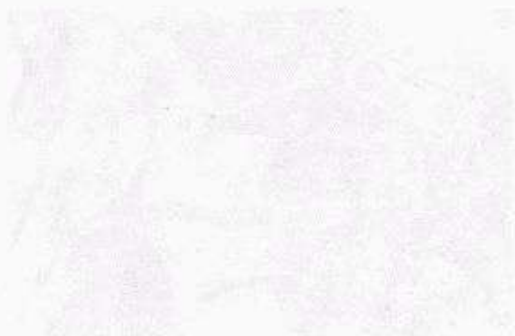

*[The text in this section is extremely faint and illegible, appearing to be bleed-through from the reverse side of the page.]*

## 7-4 ENGINE REMOVAL / INSTALLATION

### Engine Removal/Installation

#### Engine Removal

● Remove:

- Upper and Lower Fairings (see Frame chapter)
- Engine Oil (Drain, see Engine Lubrication System chapter)
- Coolant (Drain, see Cooling System chapter)
- Clutch Slave Cylinder (see Clutch chapter)
- Shift Pedal
- Engine Sprocket (see Final Drive chapter)
- Fuel Tank (see Fuel System chapter)
- Air Cleaner Housing (see Fuel System chapter)
- Carburetors (see Fuel System chapter)
- Baffle Plate on the Cylinder Head Cover
- Radiator (see Cooling System chapter)
- Muffler (see Engine Top End chapter)
- Bolt [A] and Thermostat Housing [B]
- Oil Cooler Hoses [C]
- Radiator Bracket [D]

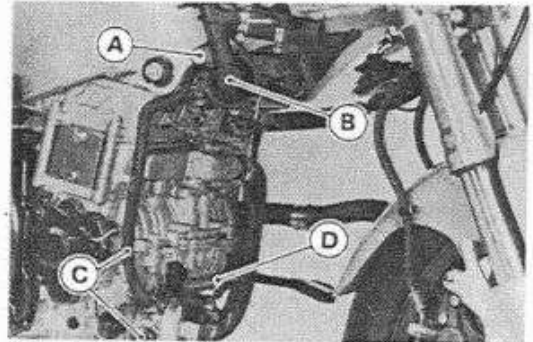

- Disconnect wiring from the engine and free them from the clamps.  
Pickup Coil and Oil Pressure Switch Lead Connector [A]  
Alternator Lead Connector [B]  
Neutral Switch Lead Connector [C]  
Battery Ground Lead [D]
- Remove the ignition coils (see Electrical System chapter).

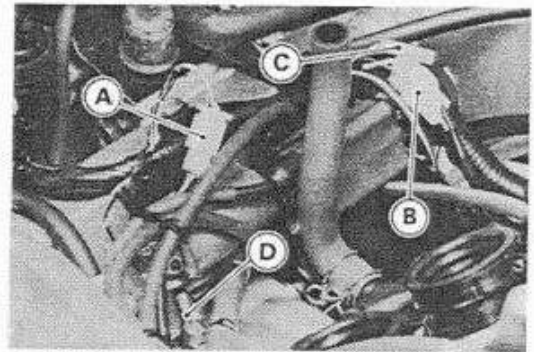

- Support the frame on the jack.

**Special Tool – Jack: 57001-1238**

- Squeeze the brake lever slowly and hold it with a band.
- Support the engine with a suitable stand.
- Loosen the engine mounting locknuts [A], using the socket wrench [B].

**Special Tool – Socket Wrench: 57001-1347**

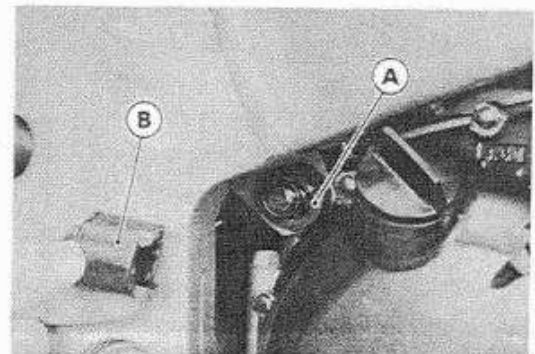

- Remove the bolts [A] and nuts.
- Screw back all the engine collar bolts for clearance around the engine.

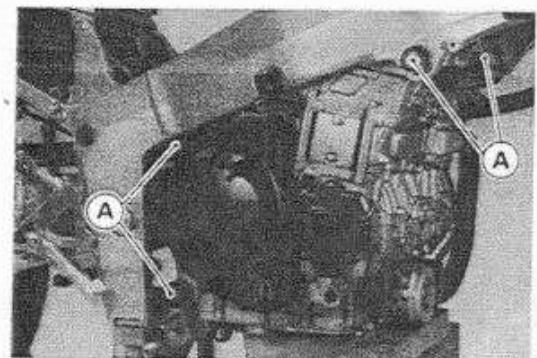

## NOTE

- The drive chain will be removed from the output shaft when removing the engine.
- Remove the engine.

*Engine Installation*

- Before engine installation, install the collar bolts [A, B] and then screw back them fully.
- Support the engine with a suitable stand, and set it at the correct position.
- Hang the drive chain over the output shaft just before moving the engine into its final position in the frame.
- Insert the rear mounting bolts [C] from the left side of the engine.
- Insert the front mounting bolts [D].
- Tighten the rear collar bolts [A].

**Torque – Engine Collar Bolts: 9.8 N-m (1.0 kg-m, 87 in-lb)**

- Pull out the front mounting bolts [D].
- Adjust a suitable stand until the bolts were pulled out easily.
- Tighten the front collar bolts [B].

**Torque – Engine Collar Bolts: 9.8 N-m (1.0 kg-m, 87 in-lb)**

- ★ If the engine contacts the frame, adjust the front collar bolts [B].
- Tighten the mounting bolts [C, D].

**Torque – Engine Mounting Bolts and Nuts: 59 N-m (6.0 kg-m, 43 ft-lb)**

- Tighten the engine mounting locknuts [E], using the socket wrench.

**Special Tool – Socket Wrench: 57001-1347**

**Torque – Engine Mounting Locknut: 49 N-m (5.0 kg-m, 36 ft-lb)**

- Install the removed parts (see appropriate chapters).
- Adjust:
  - Throttle Cables (see Fuel System chapter)
  - Choke Cable (see Fuel System chapter)
  - Drive Chain (see Final Drive chapter)

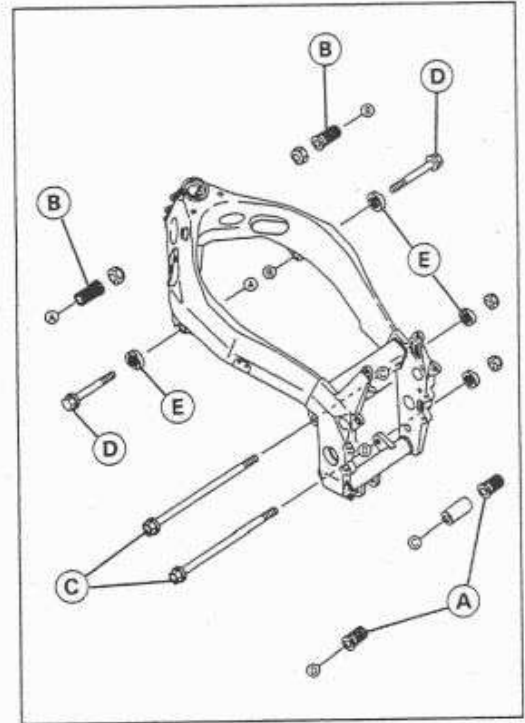

NOTE

1. The lifting device will be used to lift the engine from the engine compartment.  
 2. The lifting device should be used to lift the engine from the engine compartment.  
 3. The lifting device should be used to lift the engine from the engine compartment.

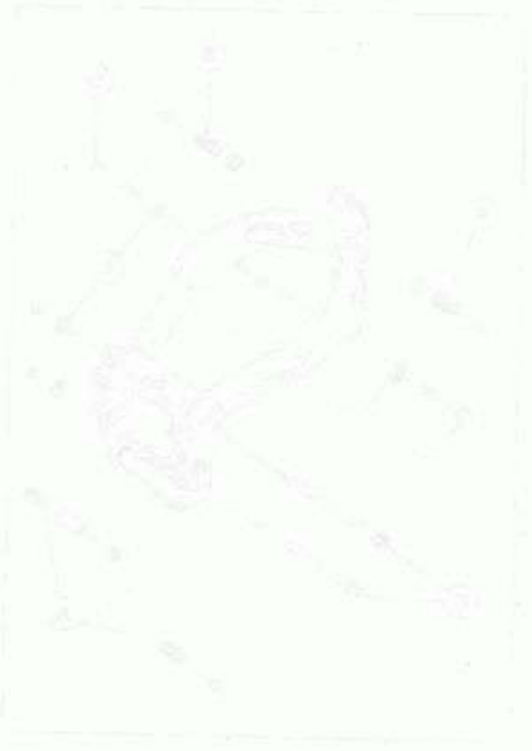

1. The lifting device will be used to lift the engine from the engine compartment.  
 2. The lifting device should be used to lift the engine from the engine compartment.  
 3. The lifting device should be used to lift the engine from the engine compartment.  
 4. The lifting device should be used to lift the engine from the engine compartment.  
 5. The lifting device should be used to lift the engine from the engine compartment.  
 6. The lifting device should be used to lift the engine from the engine compartment.  
 7. The lifting device should be used to lift the engine from the engine compartment.  
 8. The lifting device should be used to lift the engine from the engine compartment.  
 9. The lifting device should be used to lift the engine from the engine compartment.  
 10. The lifting device should be used to lift the engine from the engine compartment.  
 11. The lifting device should be used to lift the engine from the engine compartment.  
 12. The lifting device should be used to lift the engine from the engine compartment.  
 13. The lifting device should be used to lift the engine from the engine compartment.  
 14. The lifting device should be used to lift the engine from the engine compartment.  
 15. The lifting device should be used to lift the engine from the engine compartment.

# Crankshaft / Transmission

## Table of Contents

Exploded View .....	8-2	Starter Clutch Disassembly .....	8-17
Specifications .....	8-4	Starter Clutch Assembly .....	8-17
Crankcase Splitting .....	8-6	Alternator Shaft Chain Wear .....	8-17
Crankcase Splitting .....	8-6	Chain Guide Wear .....	8-18
Crankcase Assembly .....	8-6	Starter Clutch Inspection .....	8-18
Crankshaft and Connecting Rods .....	8-8	Starter Motor Idle Gear .....	8-19
Crankshaft Removal .....	8-8	Starter Motor Idle Gear Removal .....	8-19
Crankshaft Installation .....	8-8	Starter Motor Idle Gear Installation .....	8-19
Connecting Rod Removal .....	8-8	Transmission .....	8-20
Connecting Rod Installation .....	8-8	Shift Pedal Removal .....	8-20
Connecting Rod Big End		Shift Pedal Installation .....	8-20
Bearing Insert/Crankpin Wear .....	8-11	External Shift Mechanism Removal .....	8-20
Crankshaft Main Bearing Insert/ Journal Wear .....	8-12	External Shift Mechanism Installation .....	8-21
Crankshaft Side Clearance .....	8-14	External Shift Mechanism Assembly .....	8-21
Alternator Chain / Alternator Shaft /		Transmission Shaft Removal .....	8-22
Starter Clutch .....	8-15	Transmission Shaft Installation .....	8-22
Alternator Chain Adjustment .....	8-15	Transmission Disassembly .....	8-22
Alternator Chain Removal .....	8-15	Transmission Assembly .....	8-22
Alternator Chain Installation .....	8-16	Shift Drum and Fork Removal .....	8-23
Alternator Shaft, Starter Clutch Removal .....	8-16	Shift Drum and Fork Installation .....	8-23
Alternator Shaft, Starter Clutch Installation .....	8-17	Shift Drum Disassembly .....	8-24
		Shift Drum Assembly .....	8-24

# 8-2 CRANKSHAFT / TRANSMISSION

## Exploded View

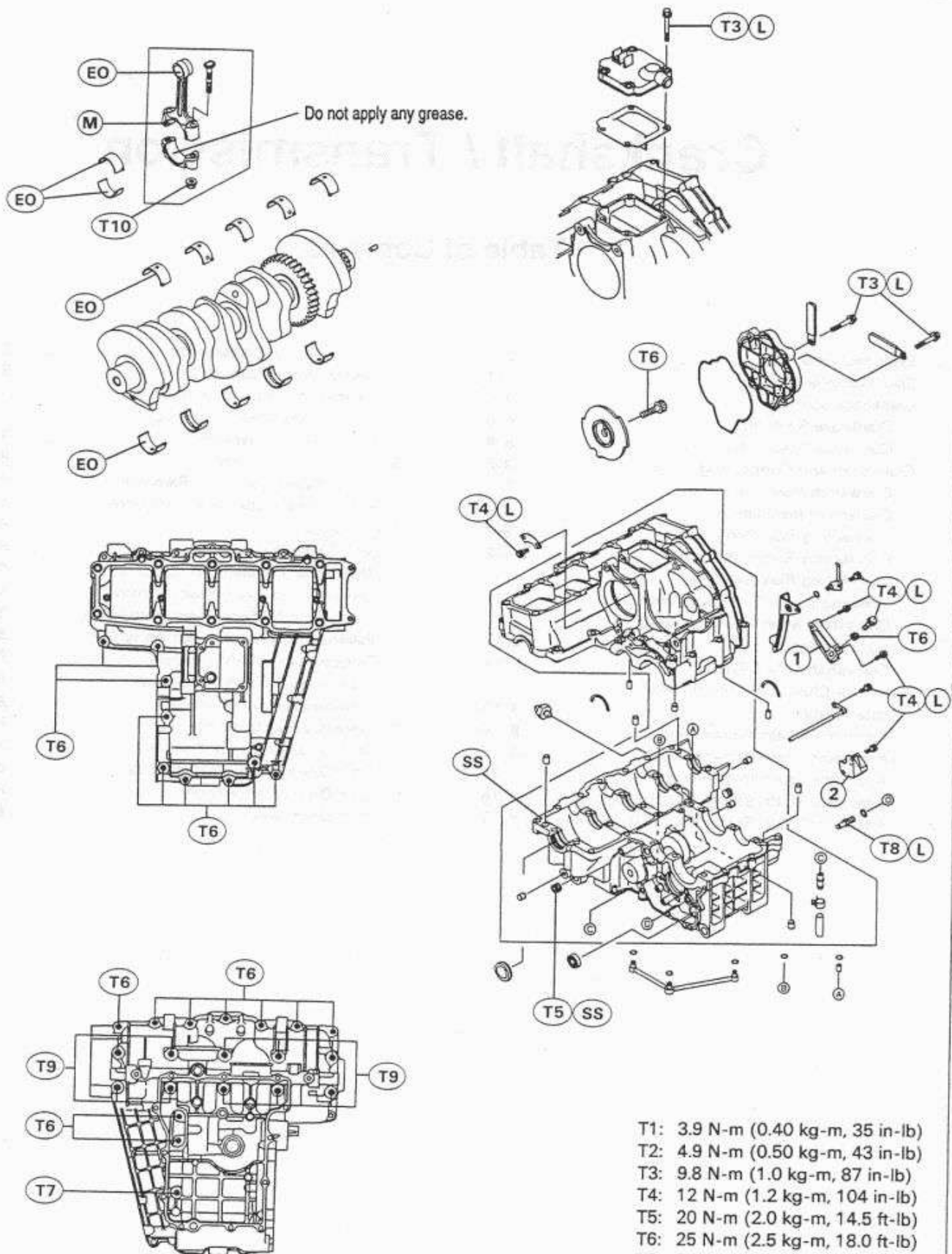

- T1: 3.9 N-m (0.40 kg-m, 35 in-lb)
- T2: 4.9 N-m (0.50 kg-m, 43 in-lb)
- T3: 9.8 N-m (1.0 kg-m, 87 in-lb)
- T4: 12 N-m (1.2 kg-m, 104 in-lb)
- T5: 20 N-m (2.0 kg-m, 14.5 ft-lb)
- T6: 25 N-m (2.5 kg-m, 18.0 ft-lb)
- T7: 27 N-m (2.8 kg-m, 20 ft-lb)
- T8: 42 N-m (4.3 kg-m, 31 ft-lb)
- T9: 44 N-m (4.5 kg-m, 33 ft-lb)
- T10: See the text.



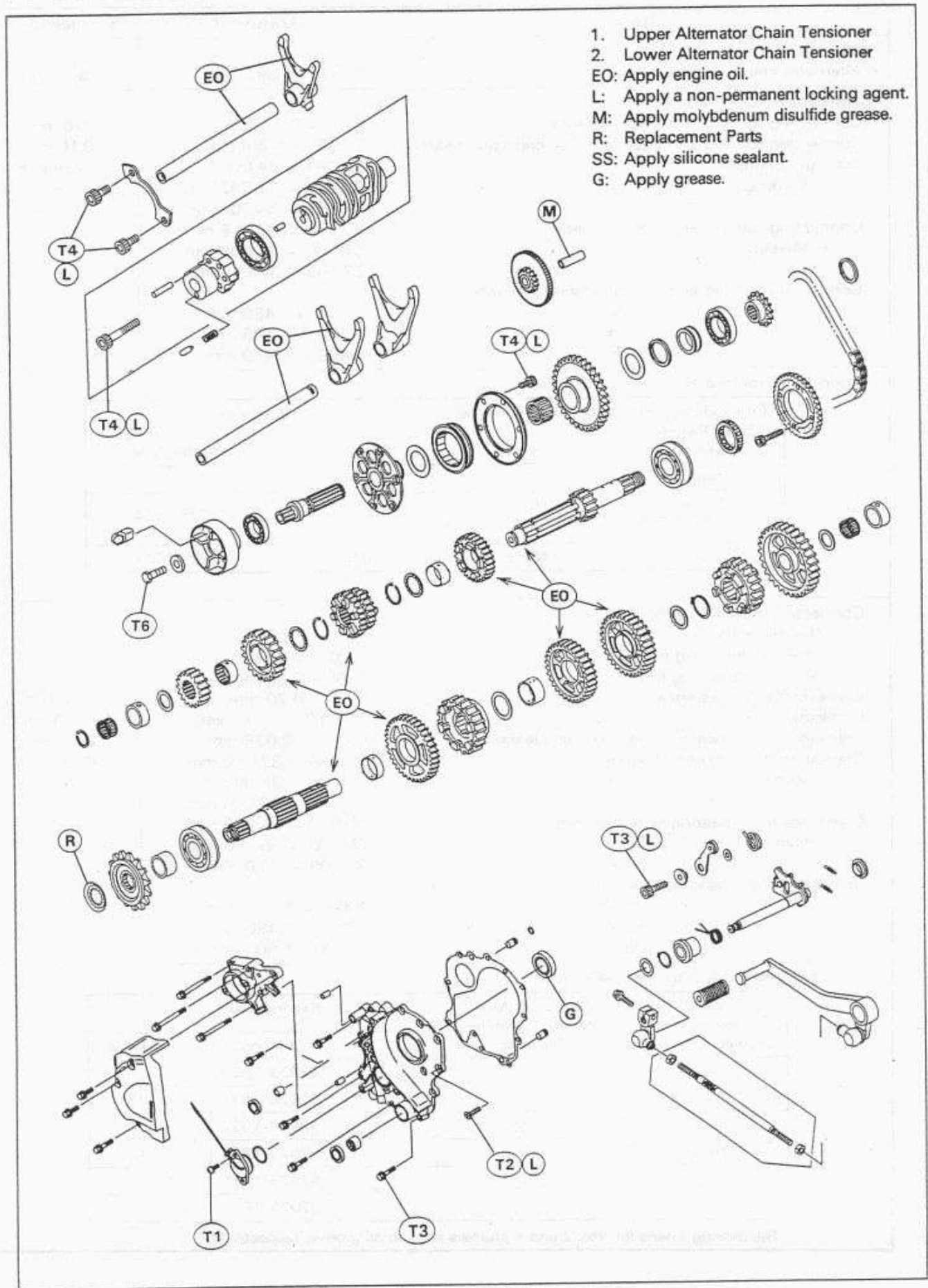

1. Upper Alternator Chain Tensioner
  2. Lower Alternator Chain Tensioner
- EO: Apply engine oil.  
 L: Apply a non-permanent locking agent.  
 M: Apply molybdenum disulfide grease.  
 R: Replacement Parts  
 SS: Apply silicone sealant.  
 G: Apply grease.

## 8-4 CRANKSHAFT / TRANSMISSION

### Specifications

Item	Standard	Service Limit
<b>Alternator Chain:</b> Alternator chain 20-link length	158.8 ~ 159.2 mm	161.0 mm
<b>Crankshaft, Connecting Rods:</b> Connecting rod big end side clearance	0.13 ~ 0.38 mm	0.6 mm
Connecting rod big end bearing insert/crankpin clearance	0.036 ~ 0.066 mm	0.10 mm
Crankpin diameter:	33.984 ~ 34.000 mm	33.96 mm
Marking           None	33.984 ~ 33.992 mm	---
○	33.993 ~ 34.000 mm	---
Connecting rod big end bore diameter:	37.000 ~ 37.016 mm	---
Marking           None	37.000 ~ 37.008 mm	---
○	37.009 ~ 37.016 mm	---
Connecting rod big end bearing insert thickness:		
Brown	1.475 ~ 1.480 mm	---
Black	1.480 ~ 1.485 mm	---
Blue	1.485 ~ 1.490 mm	---

#### Connecting rod big end bearing insert selection:

Con-rod Big End Bore Diameter Marking	Crankpin Diameter Marking	Bearing Insert	
		Size Color	Part Number
None	○	Brown	92028-1625
None	None	Black	92028-1624
○	○		
○	None	Blue	92028-1623

<b>Connecting Rod Bolt Stretch (Usable Range)</b> New connecting rod	0.20 ~ 0.32 mm	---
Used connecting rod	0.24 ~ 0.36 mm	---
Crankshaft side clearance	0.05 ~ 0.20 mm	0.40 mm
Crankshaft runout	TIR 0.02 mm or less	TIR 0.05 mm
Crankshaft main bearing insert/journal clearance	0.012 ~ 0.036 mm	0.07 mm
Crankshaft main journal diameter:	31.984 ~ 32.000 mm	31.96 mm
Marking           None	31.984 ~ 31.992 mm	---
1	31.993 ~ 32.000 mm	---
Crankcase main bearing bore diameter:	35.000 ~ 35.016 mm	---
Marking           ○	35.000 ~ 35.008 mm	---
None	35.009 ~ 35.016 mm	---
Crankshaft main bearing insert thickness:		
Brown	1.490 ~ 1.494 mm	---
Black	1.494 ~ 1.498 mm	---
Blue	1.498 ~ 1.502 mm	---

#### Crankshaft main bearing insert selection:

Crankcase Main Bearing Bore Diameter Marking	Crankshaft Main Journal Diameter Marking	Bearing Insert*		
		Size Color	Part Number	Journal Nos.
○	1	Brown	92028-1628	1, 3, 5
			92028-1631	2, 4
○	None	Black	92028-1627	1, 3, 5
			92028-1630	2, 4
None	1	Blue	92028-1626	1, 3, 5
			92028-1629	2, 4

\*The bearing inserts for Nos. 2 and 4 journals have an oil groove, respectively.

Item	Standard	Service Limit
<b>Transmission:</b> Shift fork ear thickness Gear shift fork groove width Shift fork guide pin diameter Shift drum groove width	5.9 ~ 6.0 mm 6.05 ~ 6.15 mm 7.9 ~ 8.0 mm 8.05 ~ 8.20 mm	5.8 mm 6.25 mm 7.8 mm 8.3 mm

**Special Tool – Inside Circlip Pliers: 57001-143**  
**Outside Circlip Pliers: 57001-144**  
**Bearing Driver Set: 57001-1129**

**Sealant – Kawasaki Bond (Silicone Sealant): 56019-120**

## Crankcase Splitting

### Crankcase Splitting

- Remove the engine (see Engine Removal/Installation chapter).
- Set the engine on a clean surface and hold the engine steady while parts are being removed.
- Remove:
  - Clutch (see Clutch chapter)
  - Alternator Chain (see Alternator Chain Removal)
  - Oil Pump (see Engine Lubrication System chapter)
  - Pickup Coil (see Electrical System chapter)
- ★ If the crankshaft is to be removed, remove the pistons (see Engine Top End chapter).
- ★ If the alternator shaft is to be removed, remove the following.
  - Alternator (see Electrical System chapter)
  - Alternator Coupling (see Alternator Shaft, Starter Clutch Removal)
- Remove the upper crankcase bolts [A].

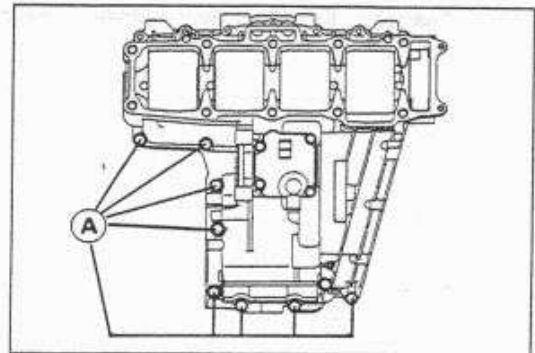

- Remove the lower crankcase bolts.
  - First loosen the 8 mm bolts.
    - 8 mm Bolts [A]
    - 9 mm Bolts [B]
- Tap lightly around the crankcase mating surface with a plastic mallet, and split the crankcase. Take care not to damage the crankcase.

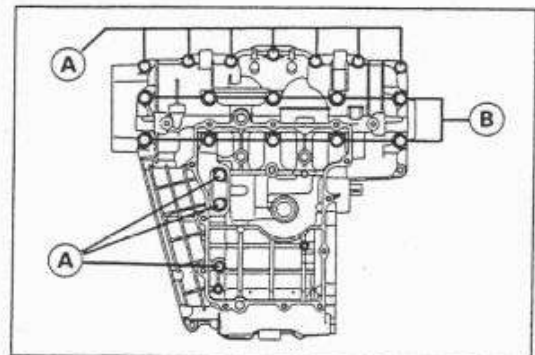

### Crankcase Assembly

#### CAUTION

The upper and lower crankcase halves are machined at the factory in the assembled state, so the crankcase halves must be replaced as a set.

- With a high-flash point solvent, clean off the mating surfaces of the crankcases halves and wipe dry.
- Using compressed air, blow out the oil passages in the crankcase halves.
- Install:
  - Camshaft Chain [A]
  - Crankshaft and Connecting Rods [B]
  - Alternator Shaft and Starter Clutch Assembly [C]
  - Starter Motor Idle Gear Assembly [D]
  - Transmission Oil Pipe [E]
  - Dowel Pins [F]
  - Nozzle and O-ring [G]
  - Plug [H]
  - O-ring [I]
  - Set Pins [J]
  - Set Rings [K]
  - Transmission Shafts and Gears
  - Shift Drum
  - Shift Forks and Shift Rods

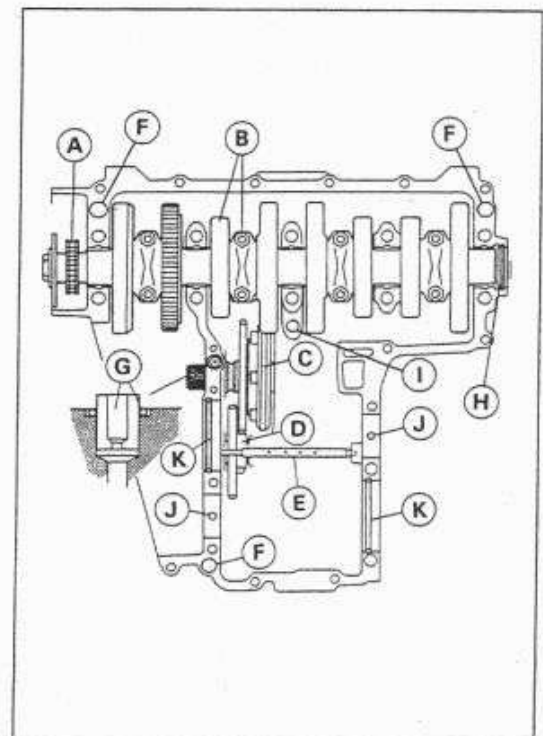

- Before fitting the lower case on the upper case, check the following.
  - Be sure to hang the camshaft chain [A] on the crankshaft.
  - Check the nozzle [B] so that the bigger diameter side faces upward.
  - Check to see that the shift drum and transmission gears are in the neutral position.

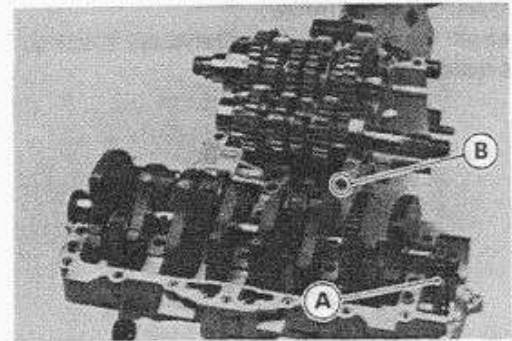

- Apply silicone sealant [A] to the mating surface of the lower crankcase half.

Sealant – Kawasaki Bond (Silicone Sealant): 56019-120

**CAUTION**

**Do not apply silicone sealant around the crankshaft main bearing inserts.**

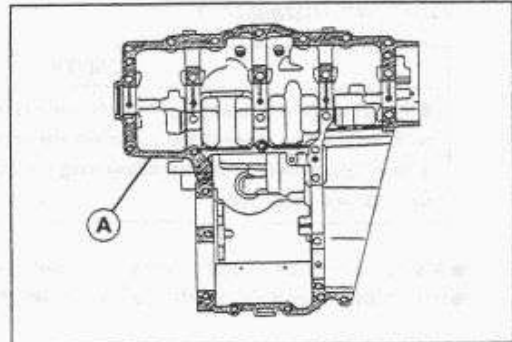

- Tighten the lower crankcase bolts.
  - Following the sequence numbers on the lower crankcase half, tighten the 9 mm bolts [A].

Torque – Crankcase 9 mm Bolts: 44 N-m (4.5 kg-m, 33 ft-lb)

- Tighten the 8 mm bolt [B].

Torque – Crankcase 8 mm Bolt: 27 N-m (2.8 kg-m, 20 ft-lb)

- Tighten the 8 mm bolts.

- [C] 40 mm length
- [D] 45 mm length

Torque – Crankcase 8 mm Bolts: 25 N-m (2.5 kg-m, 18.0 ft-lb)

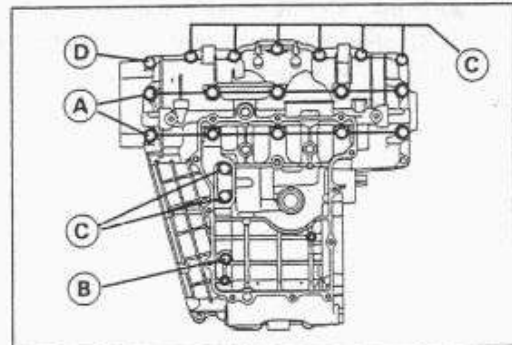

- Tighten the upper crankcase bolts.

- [A] 35 mm length
- [B] 40 mm length
- [C] 70 mm length

Torque – Crankcase 8 mm Bolts: 25 N-m (2.5 kg-m, 18.0 ft-lb)

- After tightening all crankcase bolts, check the following items.

- Drive shaft and output shafts turn freely.
- While spinning the output shaft, gears shift smoothly from the 1st to 6th gear, and 6th to 1st.
- When the output shaft stays still, the gear can not be shifted to 2nd gear or other higher gear positions.

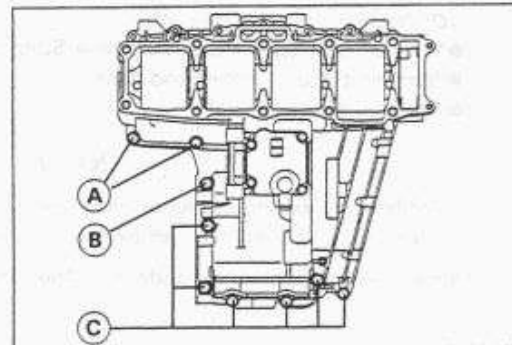

- The breather cover gasket [A] is used for separating the oil in the breather.

- When installing the breather cover [B], push [C] the gasket from left to right.

[D] Upper Crankcase

- Apply a non-permanent locking agent to the breather cover bolts and tighten them.

Torque – Breather Cover Bolts: 9.8 N-m (1.0 kg-m, 87 in-lb)

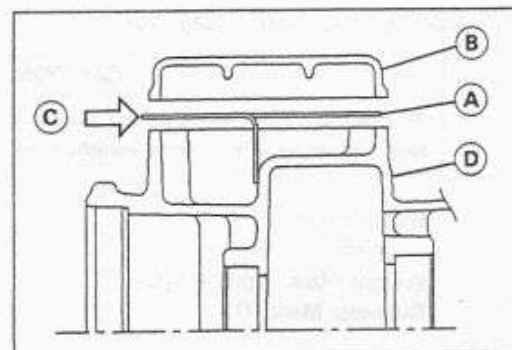

## Crankshaft and Connecting Rods

### Crankshaft Removal

- Split the crankcase (see Crankcase Splitting).
- Remove the crankshaft.

### Crankshaft Installation

#### CAUTION

If the crankshaft, bearing inserts, or crankcase halves are replaced with new ones, select the bearing inserts and check clearance with a plastigage before assembling engine to be sure the correct bearing inserts are installed.

- Apply engine oil to the crankshaft main bearing inserts.
- Install the crankshaft with the camshaft chain [A] hanging on it.
- For the ZX750N, when installing the sprocket [A] onto the crankshaft [B], align the punch mark [C] on the crankshaft with the projection [D] on the sprocket.

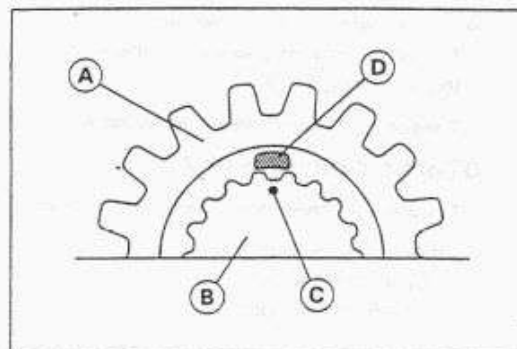
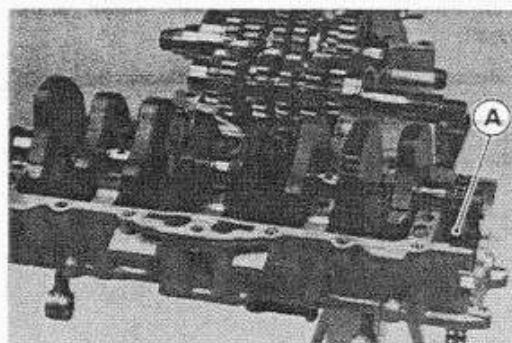

### Connecting Rod Removal

- Split the crankcase (see Crankcase Splitting).
- Remove the connecting rod nuts.
- Remove the crankshaft.

#### NOTE

○ Mark and record the locations of the connecting rods and their big end caps so that they can be reassembled in their original positions.

- Remove the connecting rods from the crankshaft.

### Connecting Rod Installation

#### CAUTION

To minimize vibration, a pair of connecting rods (left two rods or right two) should have the same weight mark.

Big End Cap [A]  
Connecting Rod [B]  
Weight Mark, Alphabet [C]  
Diameter Mark [D]

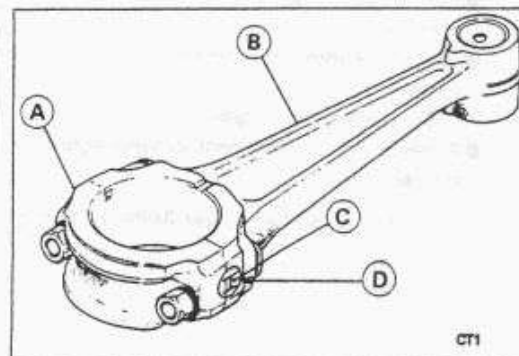

CT1

- If the connecting rods, big end bearing inserts, or crankshaft are replaced with new ones, select the bearing insert and check clearance with a plastigage before assembling engine to be sure the correct bearing inserts are installed.
- Apply molybdenum disulfide grease to the upper inner surface [A] of the connecting rod big end.
- Do not apply grease [B].
- Apply engine oil to the inner surface [C] of upper and lower bearing inserts.
- The connecting rod big end is bolted using the "plastic region fastening method".
- This method precisely achieves the needed clamping force without exceeding it unnecessarily, allowing the use of thinner, lighter bolts further decreasing connecting rod weight.
- There are two types of the plastic region fastening. One is a bolt length measurement method and other is a tightening torque method. Observe one of the following two, but the bolt length measurement method is preferable because this is a more reliable way to tighten the big end nuts.

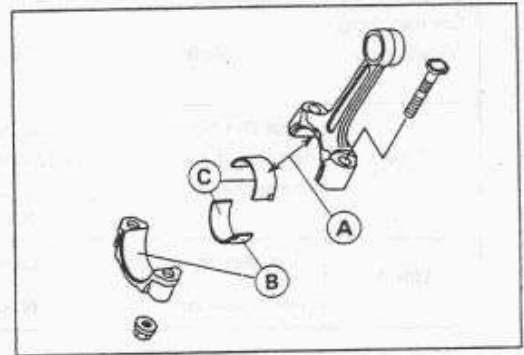

**CAUTION**

The connecting rod bolts are designed to stretch when tightened. Never reuse the connecting rod bolts. See the table below for correct bolt and nut usage.

(1) Bolt Length Measurement Method

- Be sure to clean the bolts, nuts, and connecting rods thoroughly with high-flash point solvent, because the new connecting rods, bolts, and nuts are treated with an anti-rust solution.

**▲WARNING**

Clean the bolts, nuts, and connecting rods in a well-ventilated area, and take care that there is no spark or flame anywhere near the working area. This includes any appliance with a pilot light. Because of the danger of highly flammable liquids, do not use gasoline or low-flash point solvents to clean them.

**CAUTION**

Immediately dry the bolts and nuts with compressed air after cleaning. Clean and dry the bolts and nuts completely.

- Install new bolts in reused connecting rods.
- Dent both bolt head and bolt tip with a punch as shown.
- Before tightening, use a point micrometer to measure the length of new connecting rod bolts and record the values to find the bolt stretch.
  - Connecting Rod [A]
  - Dent here with a punch [B].
  - Nuts [C]
  - Fit micrometer pins into dents [D].
- Tighten the big end nuts until the bolt elongation reaches the length specified in the table.
- Check the length of the connecting rod bolts.
- ★ If the stretch is more than the usable range, the bolt has stretched too much. An overelongated bolt may break in use.

$$\text{Bolt Length after tightening} - \text{Bolt Length before tightening} = \text{Stretch}$$

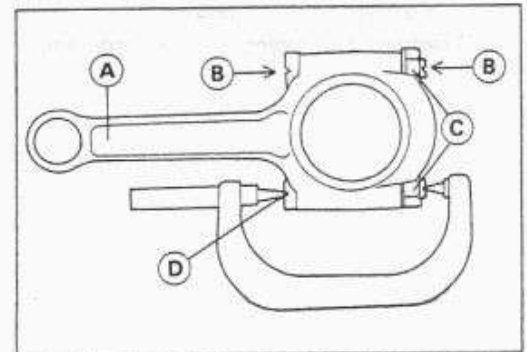

Connecting Rod Assy	Bolt	Nut	Usable Range of Connecting Rod Bolt Stretch
New	Use the bolts attached to new con-rod.	Attached to new con-rod	0.20 ~ 0.32 mm
		New	
Used	Replace the bolts with new ones.	Used	0.24 ~ 0.36 mm
		New	

## (2) Tightening Torque Method

★If you don't have a point micrometer, you may tighten the nuts using the "Tightening Torque Method".

- Be sure to clean the bolts, nuts, and connecting rods thoroughly with high-flash point solvent, because the new connecting rods, bolts, and nuts are treated with an anti-rust solution.

### ⚠WARNING

Clean the bolts, nuts, and connecting rods in a well-ventilated area, and take care that there is no spark or flame anywhere near the working area. This includes any appliance with a pilot light. Because of the danger of highly flammable liquids, do not use gasoline or low-flash point solvents to clean them.

### CAUTION

Immediately dry the bolts and nuts with compressed air after cleaning.

Clean and dry the bolts and nuts completely.

- Apply a small amount of engine oil to the threads [A] and seating surface [B] of the connecting rod nuts.

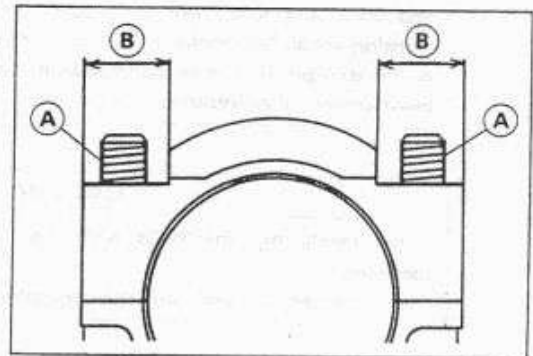

- First, tighten the nuts to the specified torque. See the table below.
- Next, tighten the nuts 120° more.
- Mark [A] the connecting rod big end caps and nuts so that nuts can be turned 120° [B] properly.
- Tighten the hexagon nut by 2 corners.

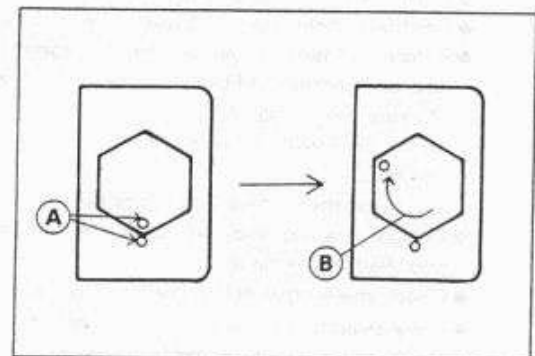



Connecting Rod Assy	Bolt	Nut	Torque + Angle N-m (kg-m, ft-lb)
New	Use the bolts attached to new con-rod.	Attached to new con-rod	18 (1.8, 13.0) + 120°
		New	20 (2.0, 14.5) + 120°
Used	Replace the bolts with new ones	Used	24 (2.4, 17.4) + 120°
		New	25 (2.6, 18.8) + 120°

**CAUTION**

Since the friction force of the seating surface and thread portion of new nuts is different from that of used ones, the nut tightening torque should be changed as specified in the above table. Be careful not to overtighten the nuts.

**Connecting Rod Big End Bearing Insert/Crankpin Wear**

- Using a plastigage (press gauge) [A], measure the bearing insert/crankpin [B] clearance.

**NOTE**

- Tighten the connecting rod big end nuts to the specified torque (see Connecting Rod Installation).
- Do not move the connecting rod and crankshaft during clearance measurement.

**Connecting Rod Big End Bearing Insert/Crankpin Clearance**

**Standard:** 0.036 ~ 0.066 mm  
**Service Limit:** 0.10 mm

- ★ If clearance is within the standard, no bearing replacement is required.
- ★ If clearance is between 0.066 mm and the service limit (0.10 mm), replace the bearing inserts with inserts painted blue [A]. Check insert/crankpin clearance with the plastigage. The clearance may exceed the standard slightly, but it must not be less than the minimum in order to avoid bearing seizure.
- ★ If the clearance exceeds the service limit, measure the diameter of the crankpins.

**Crankpin Diameter**

**Standard:** 33.984 ~ 34.000 mm  
**Service Limit:** 33.96 mm

- ★ If any crankpin has worn past the service limit, replace the crankshaft with a new one.
- ★ If the measured crankpin diameters are not less than the service limit, but do not coincide with the original diameter markings on the crankshaft, make new marks on it.

**Crankpin Diameter Marks**

**None** 33.984 ~ 33.992 mm  
 ○ 33.993 ~ 34.000 mm

Δ: Crankpin Diameter Marks, "○" mark or no mark.

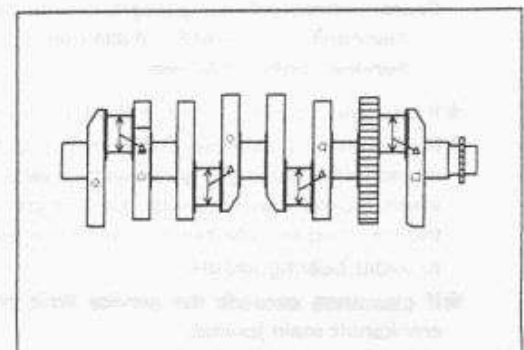
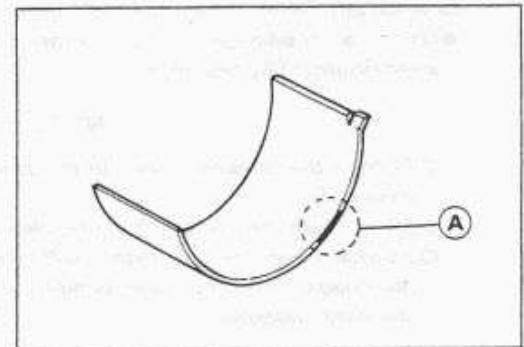
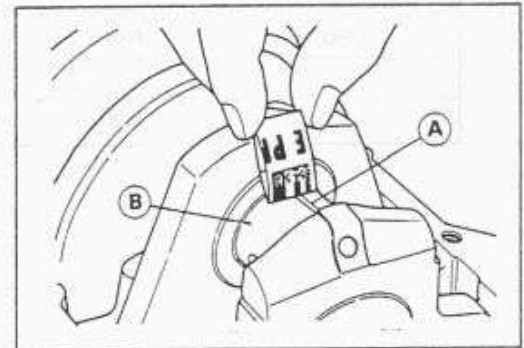

- Measure the connecting rod big end bore diameter, and mark each connecting rod big end in accordance with the bore diameter.

Bore Diameter Mark (Around Weight Mark) [A]: "○" or no mark.

### NOTE

- Tighten the connecting rod big end nuts to the specified torque (see Connecting Rod Installation).
- The mark already on the big end should almost coincide with the measurement.

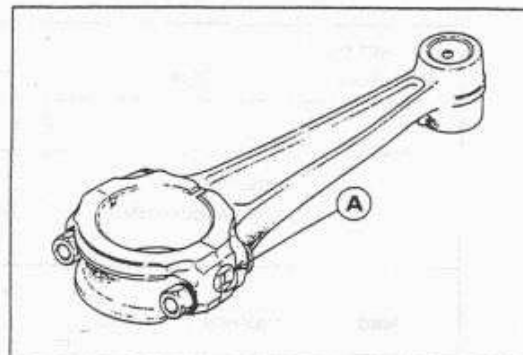

### Connecting Rod Big End Bore Diameter Marks

None	37.000 ~ 37.008 mm
○	37.009 ~ 37.016 mm

- Select the proper bearing insert in accordance with the combination of the connecting rod and crankshaft coding.
- Install the new inserts in the connecting rod and check insert/crankpin clearance with the plastigage.

Con-rod Big End Bore Diameter Marking	Crankpin Diameter Mark	Bearing Insert	
		Size Color	Part Number
None	○	Brown	92028-1625
None	None	Black	92028-1624
○	○		
○	None	Blue	92028-1623

### Crankshaft Main Bearing Insert/Journal Wear

- Using a plastigage (press gauge) [A], measure the bearing insert/journal [B] clearance.

### NOTE

- Tighten the crankcase bolts to the specified torque (see Crankcase Assembly).
- Do not turn the crankshaft during clearance measurement.
- Journal clearance less than 0.025 mm can not be measured by plastigage, however, using genuine parts maintains the minimum standard clearance.

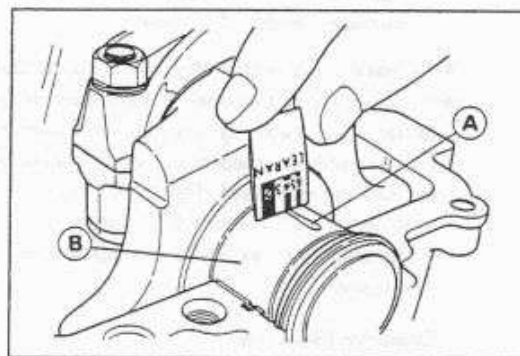

### Crankshaft Main Bearing Insert/Journal Clearance

Standard:	0.012 ~ 0.036 mm
Service Limit:	0.07 mm

- ★ If clearance is within the standard, no bearing replacement is required.
- ★ If clearance is between 0.036 mm and the service limit (0.07 mm), replace the bearing inserts with inserts painted blue [A]. Check insert/journal clearance with the plastigage. The clearance may exceed the standard slightly, but it must not be less than the minimum in order to avoid bearing seizure.
- ★ If clearance exceeds the service limit, measure the diameter of the crankshaft main journal.

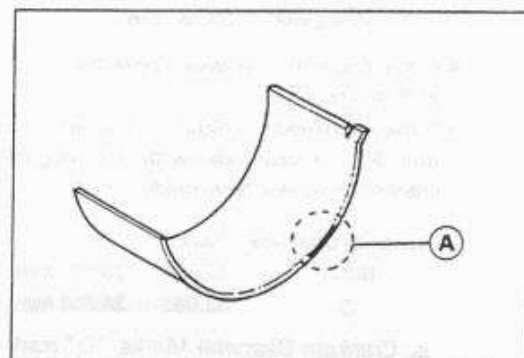

**Crankshaft Main Journal Diameter**

Standard: 31.984 ~ 32.000 mm

Service Limit: 31.96 mm

- ★ If any journal has worn past the service limit, replace the crankshaft with a new one.
- ★ If the measured journal diameters are not less than the service limit, but do not coincide with the original diameter markings on the crankshaft, make new marks on it.

**Crankshaft Main Journal Diameter Marks**

None 31.984 ~ 31.992 mm

1 31.993 ~ 32.000 mm

□: Crankshaft Main Journal Diameter Marks, "1" mark or no mark

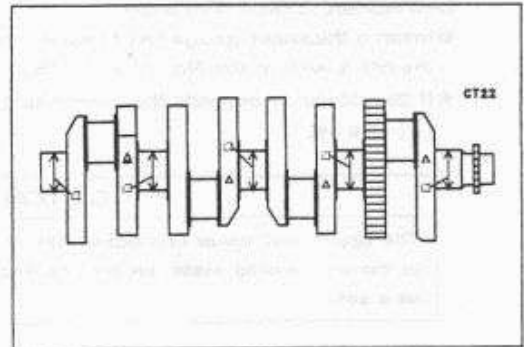

- Measure the main bearing bore diameter, and mark the upper crankcase half in accordance with the bore diameter.
- : Crankcase Main Bearing Bore Diameter Marks, "○" mark or no mark.

**NOTE**

- Tighten the crankcase bolts to the specified torque (see Crankcase Assembly).
- The mark already on the upper crankcase half should almost coincide with the measurement.

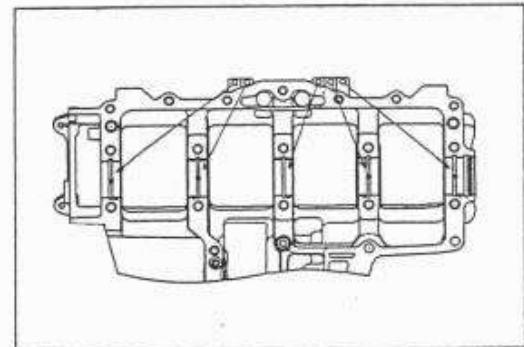

**Crankcase Main Bearing Bore Diameter Marks**

○ 35.000 ~ 35.008 mm

None 35.009 ~ 35.016 mm

- Select the proper bearing insert in accordance with the combination of the crankcase and crankshaft coding.
- Install the new inserts in the crankcase halves and check insert/journal clearance with the plastigage.

Crankcase Main Bearing Bore Diameter Marking	Crankshaft Main Journal Diameter Marking	Bearing Insert*		
		Size Color	Part Number	Journal Nos.
○	1	Brown	92028-1628	1, 3, 5
			92028-1631	2, 4
○	None	Black	92028-1627	1, 3, 5
			92028-1630	2, 4
None	1	Blue	92028-1626	1, 3, 5
			92028-1629	2, 4

\*The bearing inserts for Nos. 2 and 4 journals have an oil groove, respectively.

## Crankshaft Side Clearance

- Insert a thickness gauge [A] between the crankcase main bearing and the crank web at the No. 2 journal [B] to determine clearance.
- ★ If the clearance exceeds the service limit, replace the crankcase halves [C] as a set.

### CAUTION

The upper and lower crankcase halves are machined at the factory in the assembled state, so the crankcase halves must be replaced as a set.

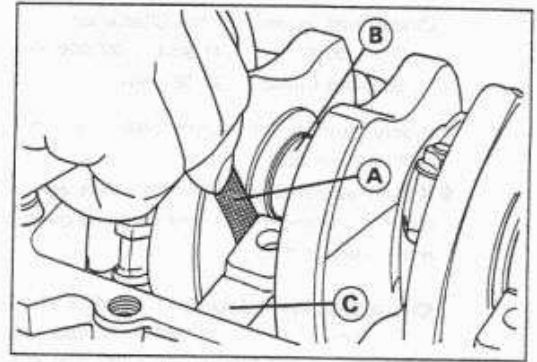

## Crankshaft Side Clearance

Standard: 0.05 ~ 0.20 mm  
Service Limit: 0.40 mm

## Alternator Chain / Alternator Shaft / Starter Clutch

## Alternator Chain Adjustment

## NOTE

○ If the alternator chain [A] makes noise, adjust the upper alternator chain tensioner [B].

## ● Remove:

- Clutch (see Clutch chapter)
- Lower Alternator Chain Tensioner [C]

## ● Loosen:

- Upper Alternator Chain Tensioner Pivot Bolt [A]
- Upper Alternator Chain Tensioner Set Bolt [B]
- Upper Alternator Chain Tensioner Locknut [C]

- Turn the upper alternator chain tensioner adjusting bolt [D] counter-clockwise until the lower part of the chain is taut, and touch the head of adjusting bolt to crankcase [E].
- Apply a non-permanent locking agent to the threads of chain tensioner pivot bolt and set bolt, and tighten them.

- Torque – Upper Alternator Chain Tensioner Pivot Bolt:**  
12 N-m (1.2 kg-m, 104 in-lb)
- Upper Alternator Chain Tensioner Set Bolt:**  
12 N-m (1.2 kg-m, 104 in-lb)

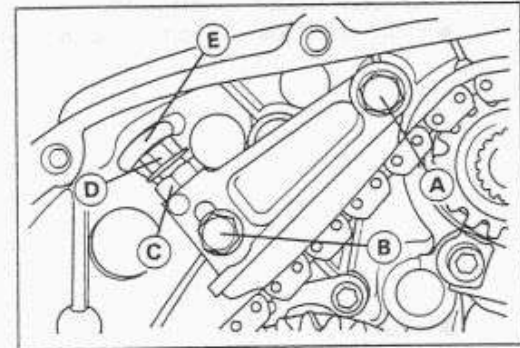
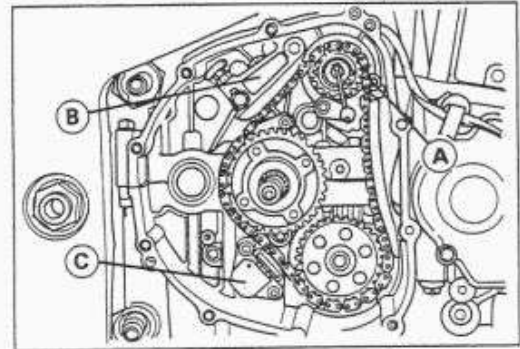

- Push the lower alternator chain tensioner pawl [A] to release the tensioner rod and push the rod [B].
- While holding the tensioner rod, install the lower alternator chain tensioner.
- Apply a non-permanent locking agent to the threads of chain tensioner bolts, and tighten them.

- Torque – Lower Alternator Chain Tensioner Bolts:** 12 N-m (1.2 kg-m, 104 in-lb)

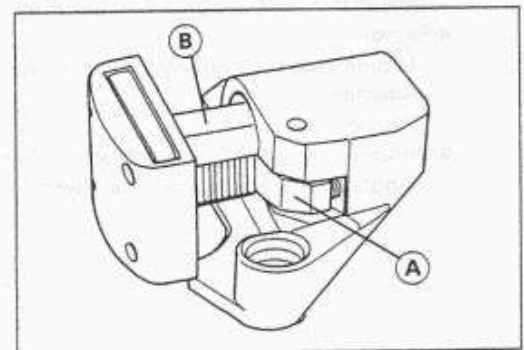

## Alternator Chain Removal

## ● Remove:

- Clutch (see Clutch chapter)
- Lower Alternator Chain Tensioner [A]
- Upper Alternator Chain Tensioner [B]
- Alternator Shaft Oil Pipe [C]

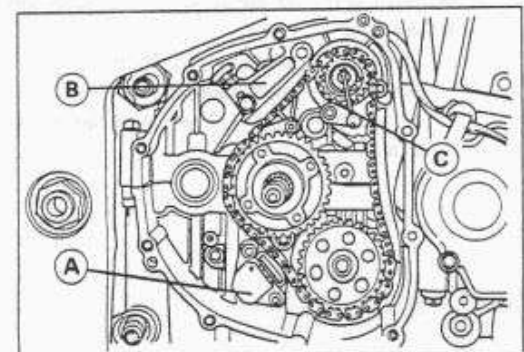

- Remove:
  - Collar [A]
  - Needle Bearing [B]
  - Chain Guide [C]
  - Drive Sprocket [D] and Spacer
  - Alternator Chain [E]

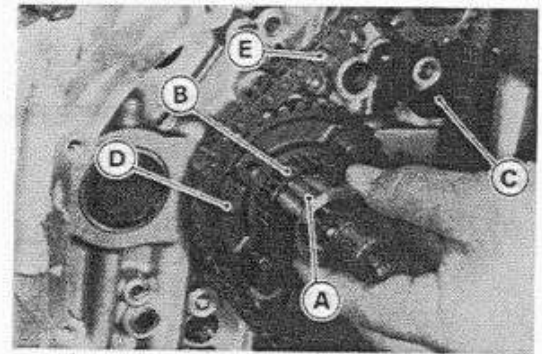

**Alternator Chain Installation**

- Install the spacer [A] so that the stepped side [B] faces inward.

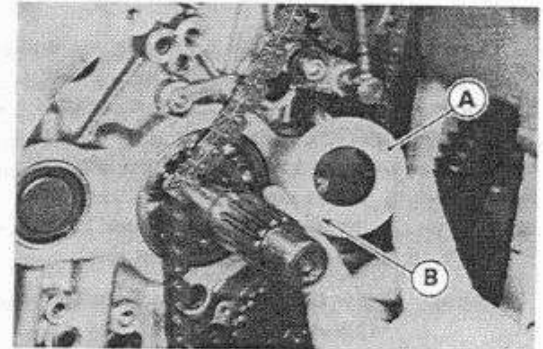

- Install:
  - Chain Guide
  - Alternator Chain
  - Alternator Shaft Oil Pipe

- Apply a non-permanent locking agent to the threads of the alternator shaft oil pipe bolt [A], and tighten it.

**Torque – Alternator Shaft Oil Pipe Bolt: 12 N-m (1.2 kg-m, 104 in-lb)**

- Install:
  - Drive Sprocket [B]
  - Needle Bearing and Collar [C]
- Adjust the alternator chain (see Alternator Chain Adjustment).

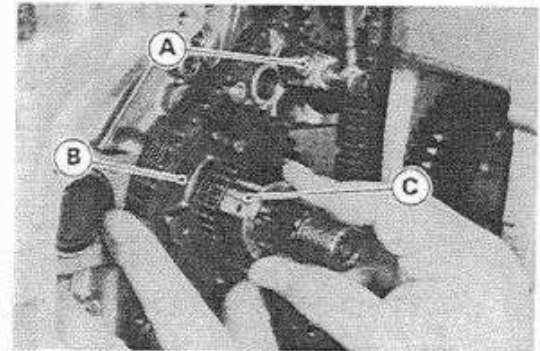

**Alternator Shaft, Starter Clutch Removal**

- Remove:
  - Engine (see Engine Removal/Installation)
  - Alternator
  - Pickup Coil Cover
- Unscrew the alternator shaft bolt [A] while holding the timing rotor hexagon head, and remove the alternator coupling dampers [B].

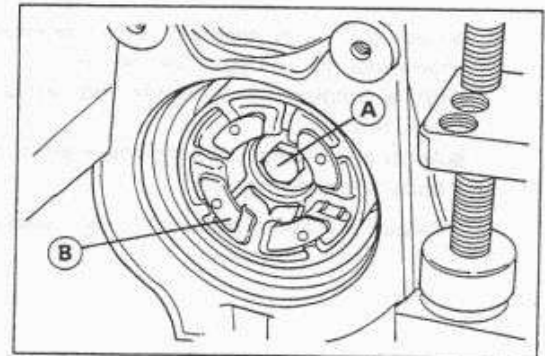

- Split the crankcase (see Crankcase Splitting).
- Remove:
  - Drive Shaft and Output Shaft
  - Alternator Shaft Bearing Holder [A]
  - Alternator Shaft [B] and Alternator Shaft Bearing [C]
  - Starter Clutch [D]

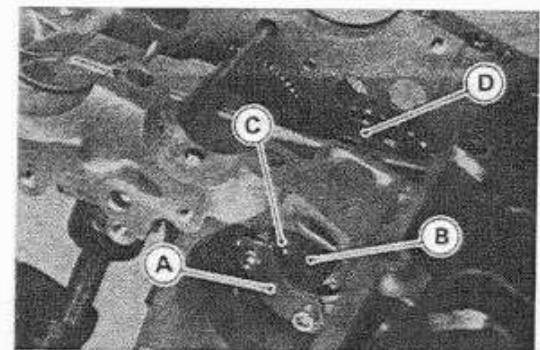

**Alternator Shaft, Starter Clutch Installation**

- ★ If the alternator shaft right end ball bearing is removed, replace the bearing with a new one.
- Press the bearing with the bearing driver set until it stops.

**Special Tool – Bearing Driver Set: 57001-1129**

- Apply a non-permanent locking agent to the threads of the alternator shaft bearing holder bolts, and tighten them.

**Torque – Alternator Shaft Bearing Holder Bolts: 12 N-m (1.2 kg-m, 104 in-lb)**

- Hold the timing rotor hexagon head, tighten the coupling bolt.

**Torque – Alternator Shaft Bolt: 25 N-m (2.5 kg-m, 18.0 ft-lb)**

**Starter Clutch Disassembly**

- Remove the circlip [A] and flat washer [B].
- Pull the starter clutch gear and take off the needle bearing and flat washer.
- Holding the starter clutch assembly in a vise, remove the holder Allen bolts and take off the one-way clutch.

**Special Tool – Outside Circlip Pliers: 57001-144**  
**Inside Circlip Pliers: 57001-143**

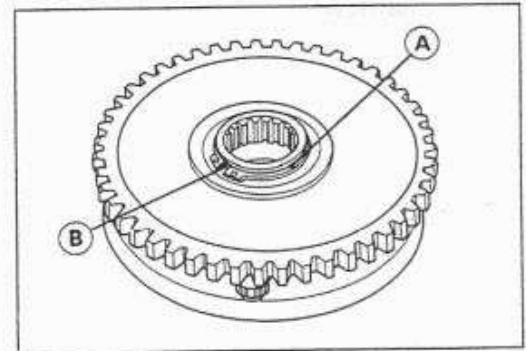

**Starter Clutch Assembly**

- Be sure to install the one-way clutch [A] so that the flange [B] of it fits in the holder recess [C].
- Apply a non-permanent locking agent to the threads of the starter clutch holder bolts, and tighten them.

**Torque – Starter Clutch Holder Bolts: 12 N-m (1.2 kg-m, 104 in-lb)**

**Special Tool – Inside Circlip Pliers: 57001-143**  
**Outside Circlip Pliers: 57001-144**

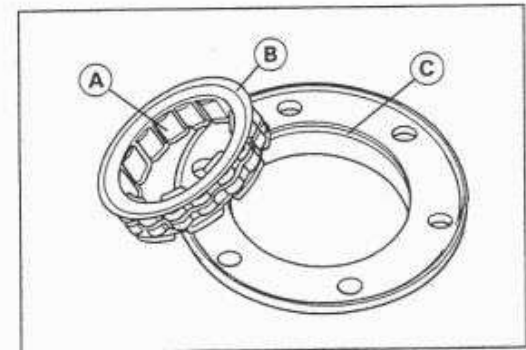

**Alternator Shaft Chain Wear**

- Hold the alternator shaft chain so that it may be pulled tight.
- Measure the length of 20 links (21 pins) with a vernier caliper.
- ★ If the 20 link length of the alternator shaft chain is greater than the service limit, replace it.

**Alternator Shaft Chain 20 link Length**  
**Standard: 158.8 ~ 159.2 mm**  
**Service Limit: 161.0 mm**

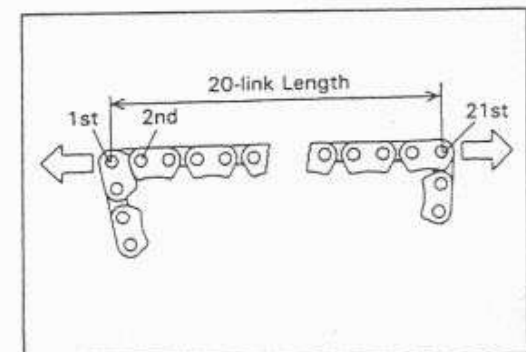

**Chain Guide Wear**

- Visually inspect the rubber on the guide.
- ★ If the rubber is cut or damaged in any way, replace the guide.

**Starter Clutch Inspection**

- Remove the starter motor.
- Turn the starter motor idle gear [A] by hand. When viewed from the left side of the engine, the idle gear should turn clockwise freely [B], but should not turn counterclockwise [C].
- ★ If the starter clutch does not operate as it should or if it makes noise, go to the next step.
- Disassemble the starter clutch, and visually inspect the clutch parts.
- ★ If there is any worn or damaged part, replace it.

**NOTE**

- Examine the starter clutch gear as well. Replace it if it is worn or damaged.

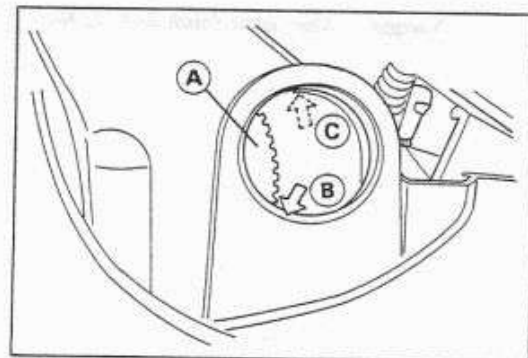



## Starter Motor Idle Gear

### Starter Motor Idle Gear Removal

- Split the crankcase (see Crankcase Splitting).
- Remove the transmission shafts.
- Pull out the starter motor idle gear shaft [A] and take off the idle gear [B].

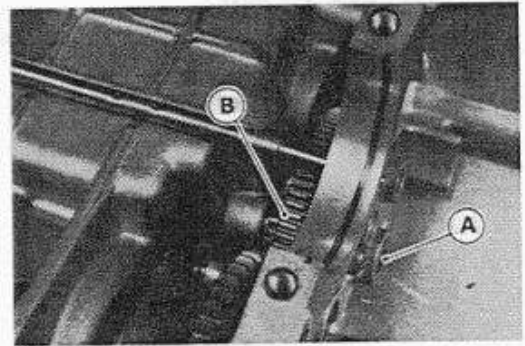

### Starter Motor Idle Gear Installation

- Install the starter motor idle gear so that the small diameter gear faces the starter motor side (right side).

## Transmission

**Shift Pedal Removal**

- Mark the position of the shift lever on the shift shaft so that it can be installed later in the same position.
- Remove the shift lever and shift pedal.

**Shift Pedal Installation**

- Install the shift pedal [A] so that the shift lever [B] positions at right angles [C] with the shift rod [D] and the center of the shift pedal meets the center line [E] of the shift rod by loosening the front and rear locknuts [F] and turning the rod.

**NOTE**

○ The locknut next to the knurled portion of the rod has left-hand threads.

★ If necessary, adjust the pedal position from the standard position to suit you as follows.

- Loosen the front and rear rod locknuts.
- Turn the rod to adjust the pedal position.
- Tighten the locknuts securely.

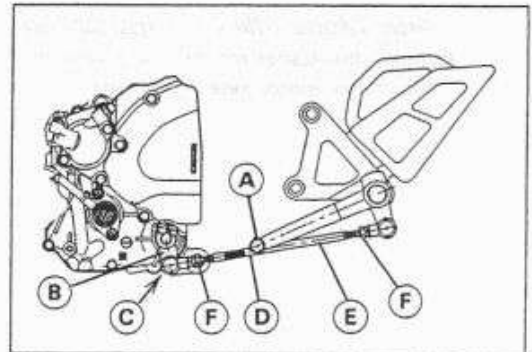
**External Shift Mechanism Removal**

- Remove:
  - Lower Fairing (see Frame chapter)
  - Water Pump (see Cooling System chapter)
  - Engine Sprocket (see Final Drive chapter)
  - Rear Wheel (see Wheels/Tires chapter)
  - Shift Lever [A]
  - Clutch Push Rod [B]
  - Neutral Switch [C]
  - Bolts [D] and Screws [E]

**NOTE**

○ Place an oil pan beneath the external shift mechanism cover.

- Pull the drive chain [A] toward the front as shown, and remove the external shift mechanism cover [B].

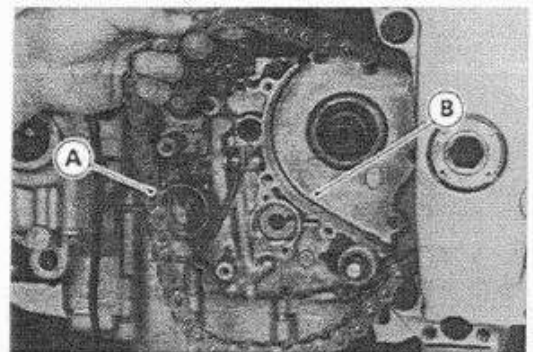
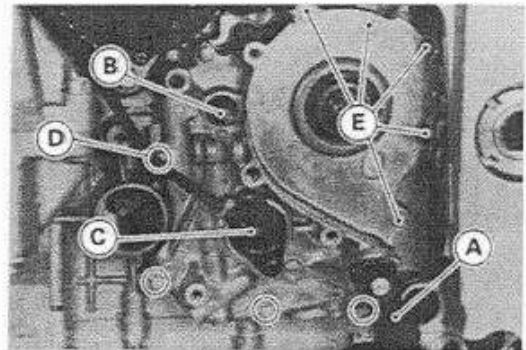

- Remove:
  - Shift Shaft [A]
  - Bolt [B]
  - Gear Positioning Lever [C]
  - Spring [D]
  - Shift Shaft Return Spring Pin [E]

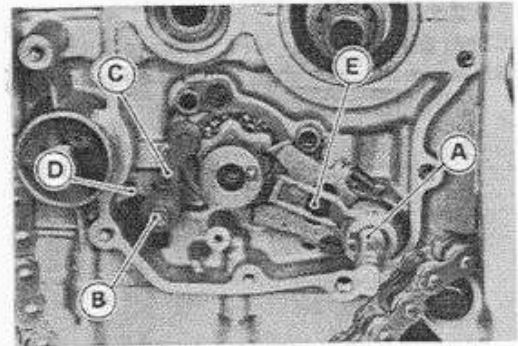

**External Shift Mechanism Installation**

- Apply a non-permanent locking agent to the threads of the gear positioning lever bolt [A].
- Install the gear positioning lever [B] and tighten the bolt.
  - Spring [C]
  - Spacer [D]

**Torque – Gear Positioning Lever Bolt: 9.8 N-m (1.0 kg-m, 87 in-lb)**

- Apply a non-permanent locking agent to the threads of the shift shaft return spring pin [E], and tighten it.

**Torque – Shift Shaft Return Spring Pin: 42 N-m (4.3 kg-m, 31 ft-lb)**

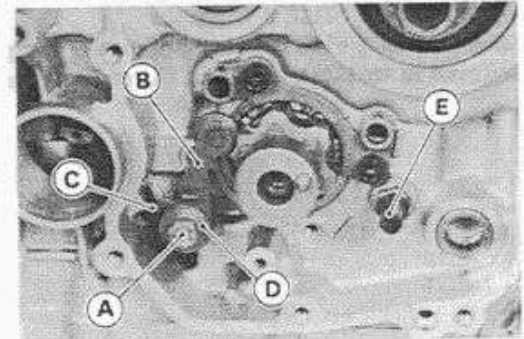

- Apply silicone sealant [A] to the crankcase halves mating surface on the front and rear sides of the external shift mechanism cover mount.

**Sealant – Kawasaki Bond (Silicone Sealant): 56019-120**

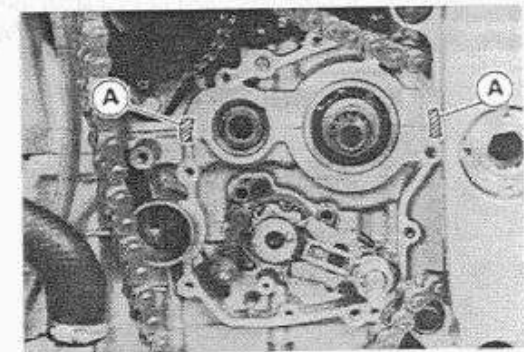

- Replace the cover gasket with a new one.
- Apply high temperature grease to the oil seal lips.
- Install the cover and tighten the cover bolts and screws.
- Apply a non-permanent locking agent to the screws [A].

**Torque – External Shift Mechanism Cover Bolts:**

**9.8 N-m (1.0 kg-m, 87 in-lb)**

**External Shift Mechanism Cover Screws:**

**4.9 N-m (0.50 kg-m, 43 in-lb)**

- Check:
  - Drive Chain Slack
  - Engine Oil Level

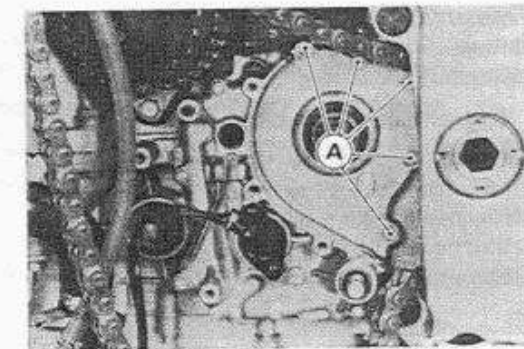

**External Shift Mechanism Assembly**

- Install the return spring [A] on the shift mechanism arm [B], noting the hook direction.

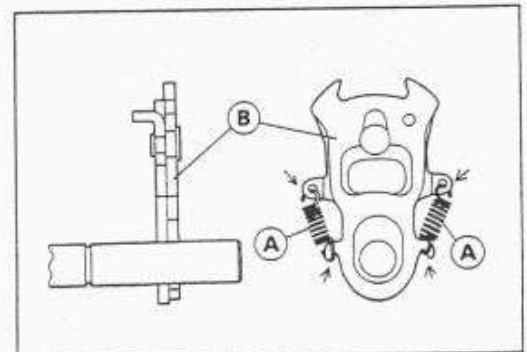

**Transmission Shaft Removal**

- Split the crankcase (see Crankcase Splitting).
- Remove the drive shaft [A] and output shaft [B].

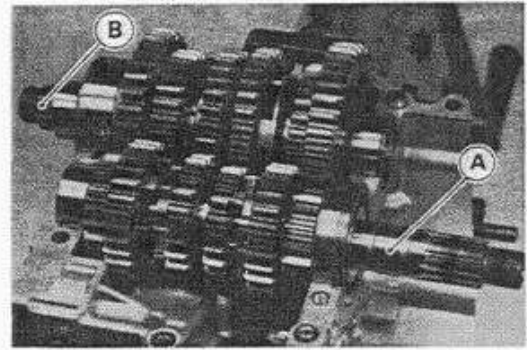

**Transmission Shaft Installation**

- Apply engine oil to the sliding portion of the gears and bearings.
- Check to see that the set pins [A] and set rings [B] are in place.

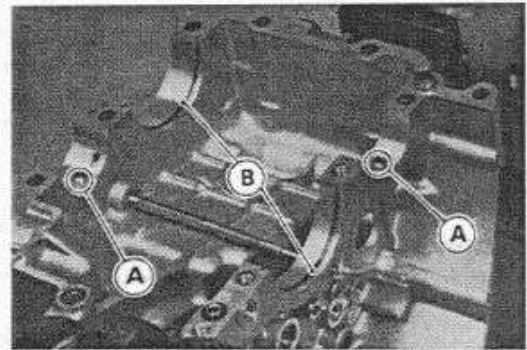

- Install the drive shaft and output shaft into the upper crankcase half.
- Fit the pin [A] in the groove [B] of the crankcase.

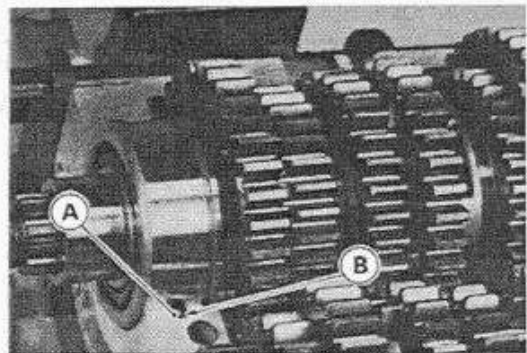

**Transmission Disassembly**

- Remove the transmission shafts (see Transmission Shaft Removal).
- Remove the circlips, disassemble the transmission shafts.

**Special Tool – Outside Circlip Pliers: 57001-144**

- The 5th gear [A] on the output shaft has three steel balls assembled into it for the positive neutral finder mechanism.
- Remove the 5th gear.
- Set the output shaft in a vertical position holding the 3rd gear [B].
- Spin the 5th gear quickly [C] and pull it off upward.

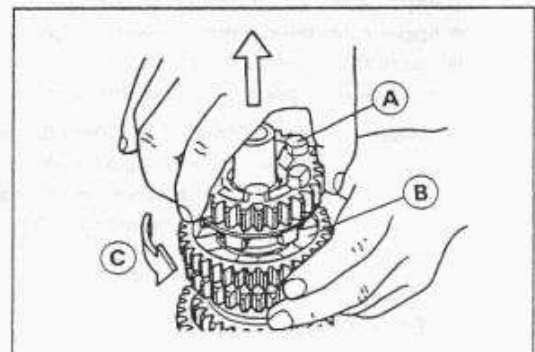

**Transmission Assembly**

- Install the gear bushings [A] on the shaft with their oil holes [B] aligned with the shaft oil holes.

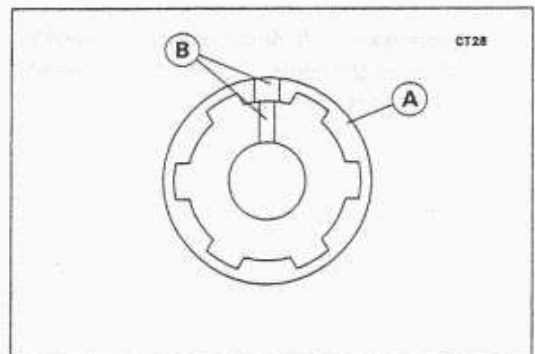

CT28

- Fit the steel balls into the 5th gear holes as shown.  
View A - A' (see the output shaft illustration)
- [A] Gear (5th)
- [B] Shaft
- [C] Steel Balls

**CAUTION**

Do not apply grease to the steel balls to hold them in place. This will cause the positive neutral finder mechanism to malfunction.

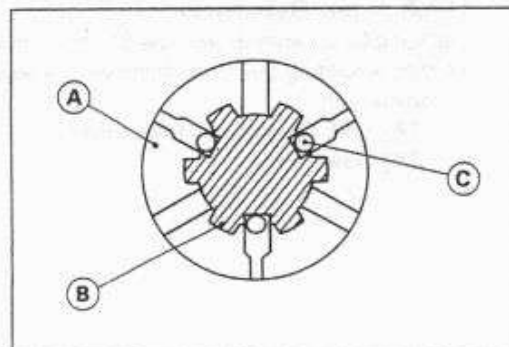

- Replace any circlip that were removed with new ones.
- Install the circlips [A] so that the opening is aligned with a spline groove [B].

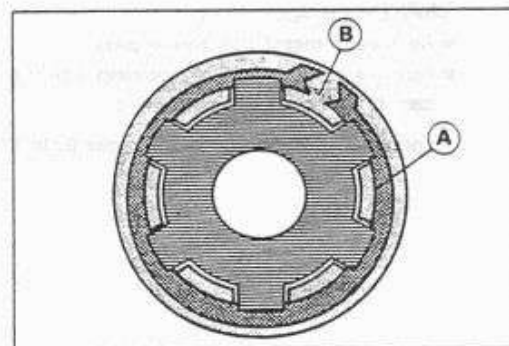

### Shift Drum and Fork Removal

- Remove:
  - Lower Crankcase Half (see Crankcase Splitting)
  - External Shift Mechanism (see External Shift Mechanism Removal)
  - Bolts [A] and Shift Drum Bearing Holder [B]
- Pull out the shift rods [C], and take off the shift forks.
- Pull out the shift drum [D].

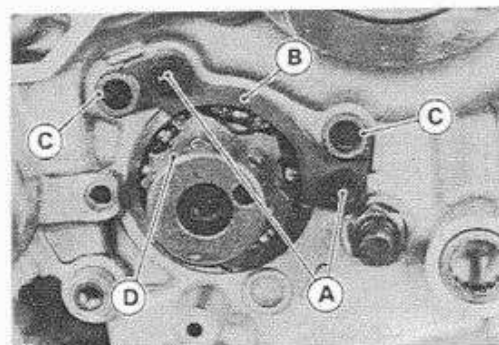

### Shift Drum and Fork Installation

- Install the shift rods, noting the groove position. The rods are identical.
- Three shift forks are used. Fit each shift fork into the groove of the proper gear so that the shift fork guide pin is in the proper groove on the shift drum.
- Position the one with shortest ears on the drive shaft and place the pin in the center groove in the shift drum.
- Of the two forks on the output shaft, each longer rib faces inward.
  - [A] Shift Rods
  - [B] Grooves
  - [C] Shorter Fork (drive)
  - [D] Longer Forks (output)
  - [E] Longer Ribs
- Apply a non-permanent locking agent to the threads of the shift drum bearing holder bolts, and tighten them.

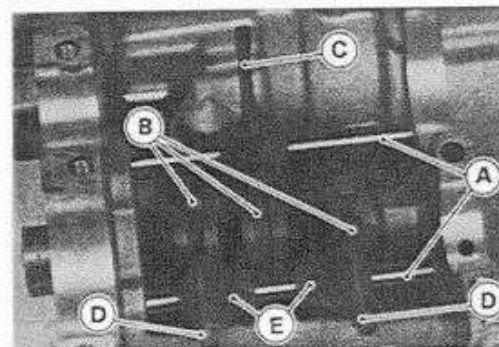

**Torque - Shift Drum Bearing Holder Bolts: 12 N-m (1.2 kg-m, 104 in-lb)**

### Shift Drum Disassembly

- Remove the shift drum (see Shift Drum and Fork Removal).
- While holding the shift drum with a vise, remove the shift drum cam holder bolt.

- [A] Shift Drum Cam Holder Bolt
- [B] Dowel Pins

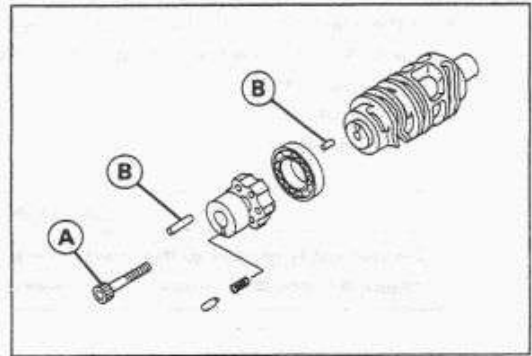

### Shift Drum Assembly

- Be sure to install the dowel pins.
- Apply a non-permanent locking agent to the threads of the shift drum cam holder bolt, and tighten it.

**Torque – Shift Drum Cam Holder Bolt: 12 N-m (1.2 kg-m, 104 In-lb)**

Drive Shaft

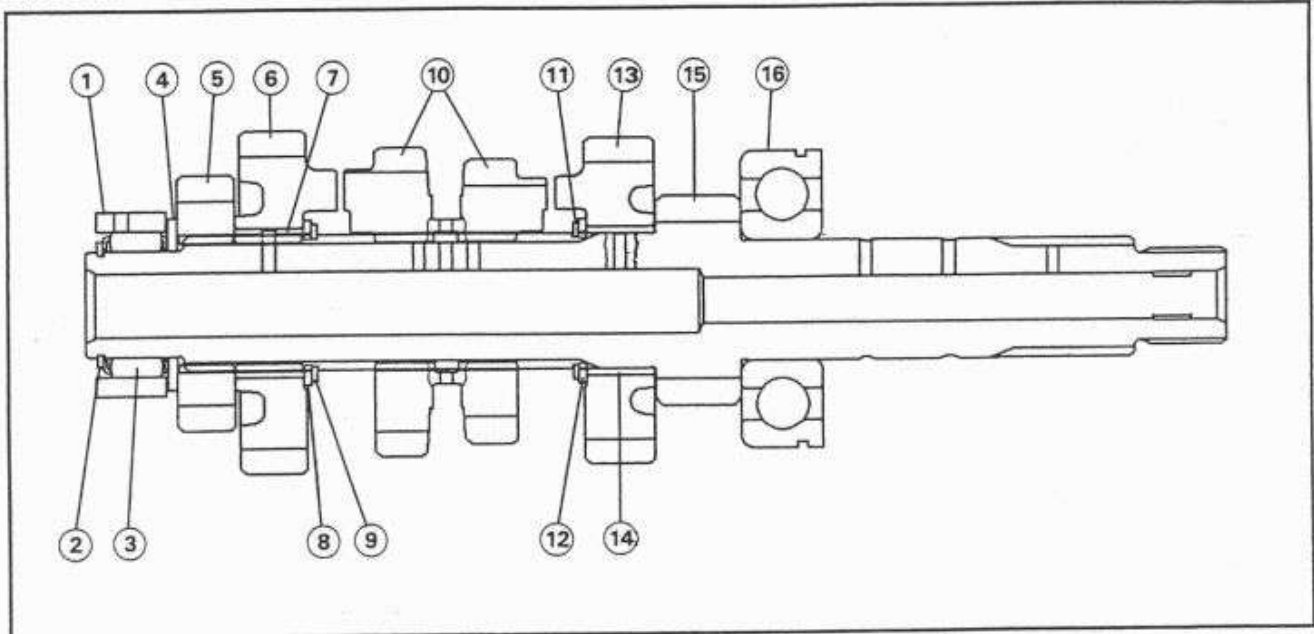

- |                       |                    |                            |
|-----------------------|--------------------|----------------------------|
| 1. Bearing Outer Race | 7. Bushing         | 13. 5th Gear               |
| 2. Circlip            | 8. Toothed Washer  | 14. Bushing                |
| 3. Needle Bearing     | 9. Circlip         | 15. 1st Gear (Drive Shaft) |
| 4. Thrust Washer      | 10. 3rd/4th Gear   | 16. Ball Bearing           |
| 5. 2nd Gear           | 11. Circlip        |                            |
| 6. Top (6th) Gear     | 12. Toothed Washer |                            |

Output Shaft

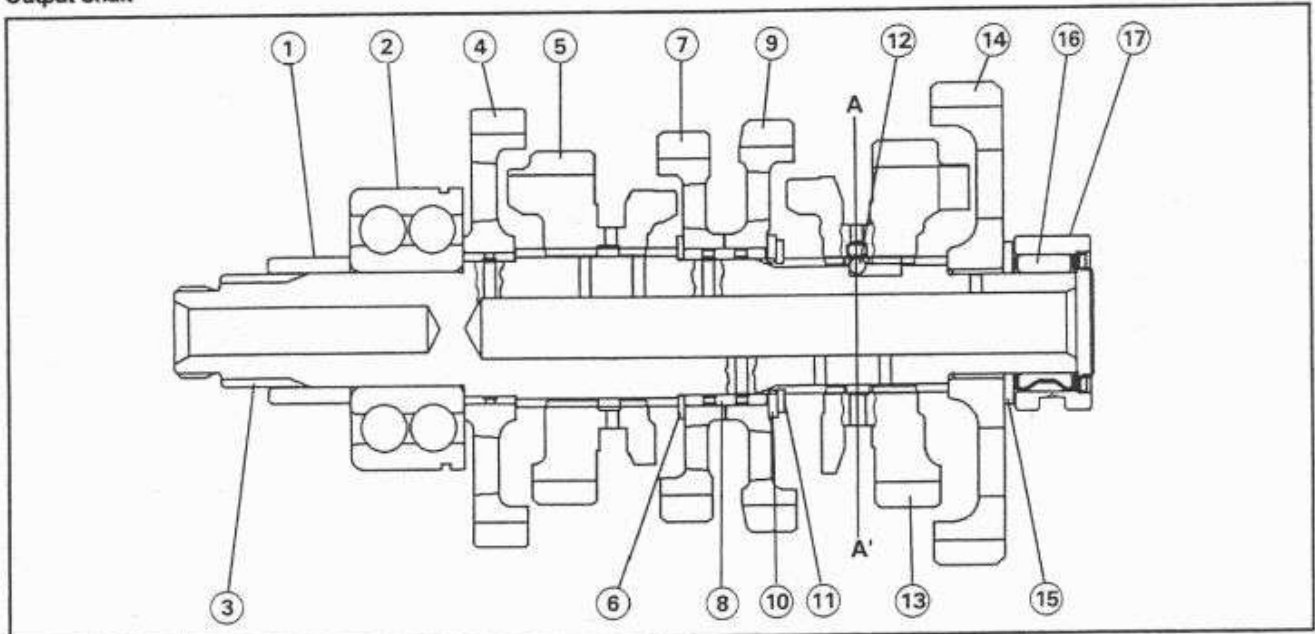

- |                       |                    |                        |
|-----------------------|--------------------|------------------------|
| 1. Collar (force fit) | 7. 4th Gear        | 13. 5th Gear           |
| 2. Ball Bearing       | 8. Bushing         | 14. 1st Gear           |
| 3. Output Shaft       | 9. 3rd Gear        | 15. Thrust Washer      |
| 4. 2nd Gear           | 10. Toothed Washer | 16. Needle Bearing     |
| 5. Top (6th) Gear     | 11. Circlip        | 17. Bearing Outer Race |
| 6. Toothed Washer     | 12. Steel Ball     |                        |

Fig. 1



- 1. Input shaft
- 2. Output shaft
- 3. Intermediate shaft
- 4. Gear set
- 5. Clutch assembly
- 6. Housing
- 7. Oil seal
- 8. Vent pipe
- 9. Drain plug
- 10. Mounting flange

Fig. 2



- 1. Input shaft
- 2. Output shaft
- 3. Intermediate shaft
- 4. Gear set
- 5. Clutch assembly
- 6. Housing
- 7. Oil seal
- 8. Vent pipe
- 9. Drain plug
- 10. Mounting flange



# Wheels / Tires

## Table of Contents

Exploded View .....	9-2
Specifications .....	9-3
Wheels (Rims) .....	9-4
Front Wheel Removal .....	9-4
Front Wheel Installation.....	9-4
Rear Wheel Removal .....	9-5
Rear Wheel Installation.....	9-5
Wheel Inspection .....	9-6
Axle Inspection .....	9-6
Balance Inspection .....	9-6
Balance Adjustment.....	9-7
Balance Weight Removal .....	9-7
Balance Weight Installation.....	9-7
Tires .....	9-9
Air Pressure Inspection/Adjustment.....	9-9
Tire Inspection .....	9-9
Tire Removal .....	9-10
Tire Installation.....	9-10
Repair .....	9-11
Hub Bearing .....	9-13
Hub Bearing Removal .....	9-13
Hub Bearing Installation.....	9-13
Hub Bearing Inspection.....	9-13
Speedometer Gear Housing.....	9-14
Disassembly and Assembly .....	9-14
Lubrication .....	9-14

Exploded View

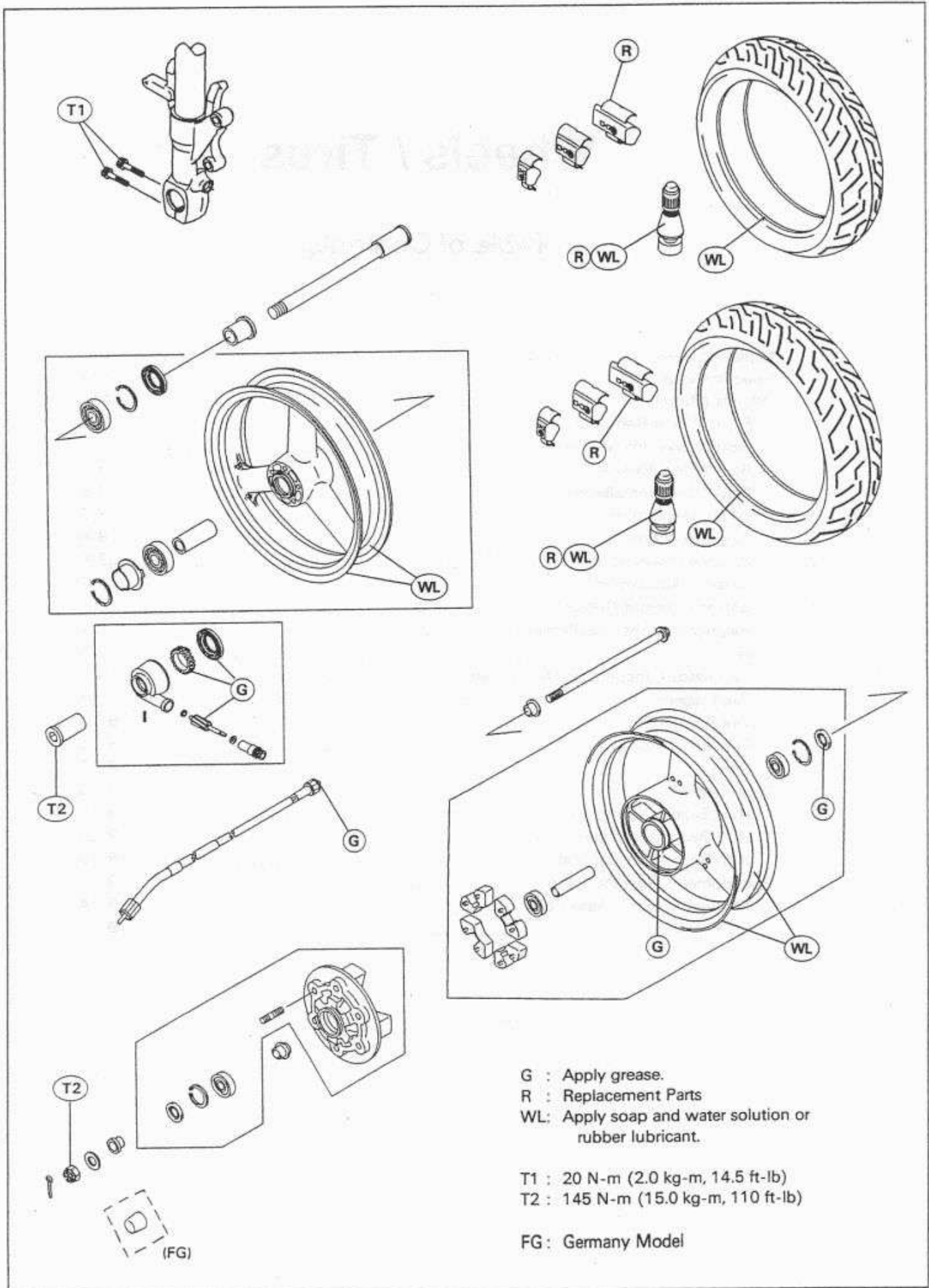

## Specifications

Item	Standard	Service Limit
<b>Wheels (Rims):</b>		
Rim runout: Axial	---	TIR 0.5 mm
Radial	---	TIR 0.8 mm
Axle runout/100 mm	TIR 0.05 mm or less	TIR 0.2 mm
Wheel balance	10 g or less	---
Balance weights	10 g, 20 g, 30 g	---
<b>Tires:</b>		
Air pressure: (when cold)		
ZX750N: Front	Up to 106 kg (233 lb) load: 230 kPa (2.3 kg/cm <sup>2</sup> , 33 psi)	---
Rear	Up to 106 kg (233 lb) load: 250 kPa (2.5 kg/cm <sup>2</sup> , 36 psi)	---
ZX750P: Front	Up to 183 kg (404 lb) load: 250 kPa (2.5 kg/cm <sup>2</sup> , 36 psi)	---
Rear	Up to 183 kg (404 lb) load: 290 kPa (2.9 kg/cm <sup>2</sup> , 41 psi)	---
<b>Tread depth:</b>		
Front	DUNLOP: 4.4 mm MICHELIN: 3.6 mm (Crown), 3 mm (Shoulder) BRIDGESTONE: 3.4 mm	1 mm 1 mm 1 mm
Rear	DUNLOP: 5.4 mm MICHELIN: 6.3 mm (Crown), 5.4 mm (Shoulder) BRIDGESTONE: 5.8 mm	Up to 130 km/h (80 mph): 2 mm Over 130 km/h (80 mph): 3 mm
<b>Standard tires:</b>	<b>Make, Type</b>	<b>Size</b>
ZX750N: Front	DUNLOP, D204FGP TYPE1, Tubeless MICHELIN, TX15 HI-SPORT, Tubeless (EU) PIRELLI, MTR01, Tubeless (EU) METZELER, MEZ1 Front, Tubeless	120/70 ZR17
Rear	DUNLOP, D204GP TYPE1, Tubeless MICHELIN, TX25 HI-SPORT, Tubeless (EU) PIRELLI, MTR02, Tubeless (EU) METZELER, MEZ1, Tubeless	190/50 ZR17
ZX750P: Front	DUNLOP, D204FL, Tubeless BRIDGESTONE, BATTLEAX BT-50F, Tubeless PIRELLI, MTR01, Tubeless METZELER, MEZ1 Front, Tubeless	120/70 ZR17
Rear	DUNLOP, D204L, Tubeless BRIDGESTONE, BATTLEAX BT-50R, Tubeless PIRELLI, MTR02, Tubeless METZELER, MEZ1, Tubeless	190/50 ZR17

(EU): European Model

**Special Tool – Jack: 57001-1238****Inside Circlip Pliers: 57001-143****Bearing Driver Set: 57001-1129****Bearing Remover Shaft: 57001-1265****Bearing Remover Head,  $\Phi 25 \times \Phi 28$ : 57001-1346**

**Additional Standard Tires (ZX750P):**

Standard tires	Make, Type	Size
ZX750P: Front	(FG) BRIDGESTONE: BATTLEAX BT-56F, Tubeless BATTLEAX BT-57F, Tubeless (FG) DUNLOP, D204F, Tubeless (FG) METZELER, MEZ1 RACING, Tubeless (FG) MICHELIN, TX15, Tubeless (FG) PIRELLI, MTR01 CORSA, Tubeless	120/70 ZR17
	(FG) BRIDGESTONE: BATTLEAX BT-56R, Tubeless BATTLEAX BT-57R, Tubeless	180/55 ZR17
	(FG) DUNLOP, D204, Tubeless (FG) METZELER, MEZ1 RACING, Tubeless (FG) MICHELIN, TX25, Tubeless (FG) PIRELLI, MTR02 CORSA, Tubeless	190/50 ZR17

(FG): German Model

**⚠ WARNING**

Use the same manufacturer's on both front and rear wheels.  
Use BATTLEAX BT56-F: BT-56R, and BATTLEAX BT-57F: BT-57R as a set, respectively.

**NOTE**

○ Most countries may have their own regulations, requiring a minimum tire tread depth; be sure to follow them.



(mirrored text)

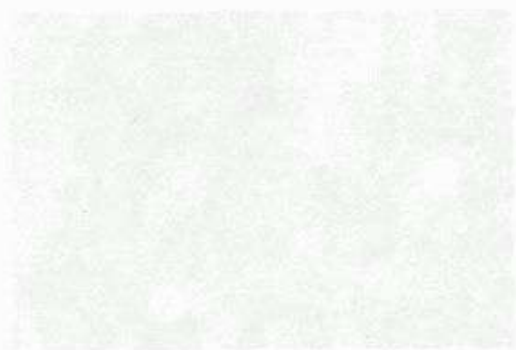

(mirrored text)

(mirrored text)

(mirrored text)



(mirrored text)

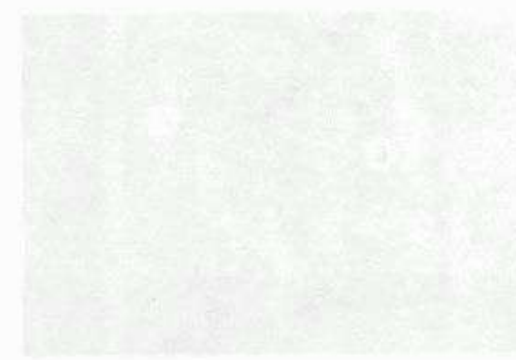

(mirrored text)

**Wheels (Rims)**

*Front Wheel Removal*

● Remove:

- Lower Fairings (see Frame chapter)
- Speedometer Cable Lower End [A]
- Brake Caliper Mounting Bolts [B]

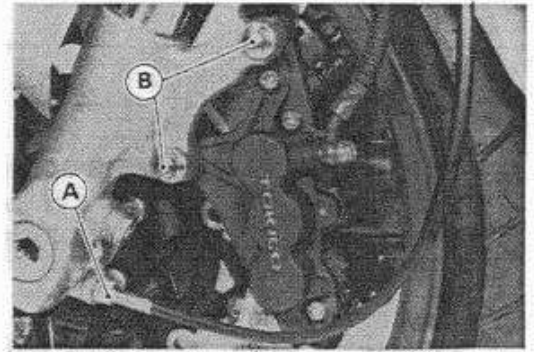

● Loosen:

- Right Side Axle Clamp Bolts [A]
- Axle [B]

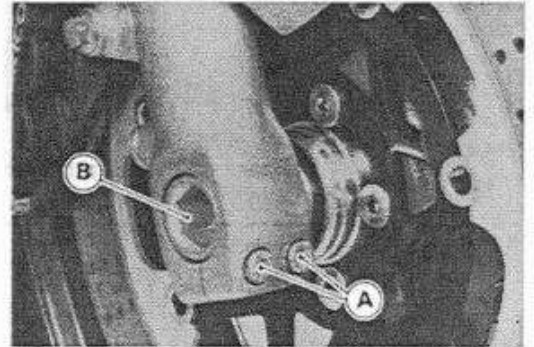

● Raise the front wheel off the ground.

Special Tool – Jack: 57001-1238

● Pull out the axle to the right and drop the front wheel out of the forks.

**CAUTION**

Do not lay the wheel down on one of the discs. This can damage or warp the disc. Place blocks under the wheel so that the disc does not touch the ground.

*Front Wheel Installation*

● Install the speedometer gear housing so that its projections [A] fit into the gear drive notches [B] in the wheel hub.

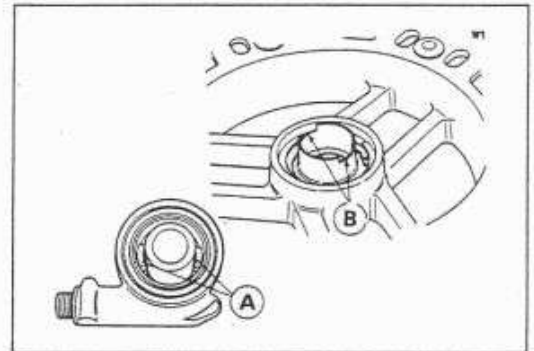

- Fit the collar on the right side of the hub.
- Fit the speedometer gear housing stop [A] in the fork leg stops [B].
- Tighten the axle nut and axle clamp bolt.

**Torque – Front Axle Nut: 145 N-m(15.0 kg-m, 110 ft-lb)**  
**Front Axle Clamp Bolts: 20 N-m(2.0 kg-m, 14.5 ft-lb)**

- Install the front brake caliper (see Brakes chapter).
- Check the front brake.

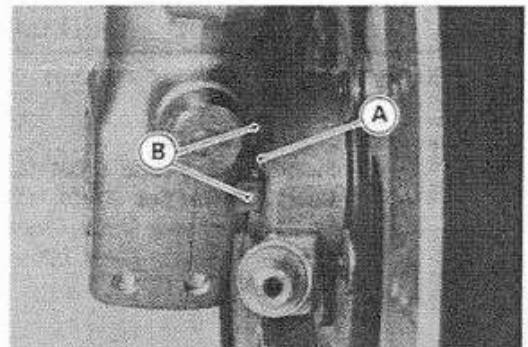

**⚠ WARNING**

Do not attempt to drive the motorcycle until a full brake lever is obtained by pumping the brake lever until the pads are against the disc. The brake will not function on the first application of the lever if this is not done.

**Rear Wheel Removal**

- Remove:
    - Lower Fairings (see Frame chapter)
    - Right Lower Fairing Stay
    - Side Stand
  - Using the jack [A], raise the rear wheel off the ground.
- Special Tool – Jack: 57001-1238**

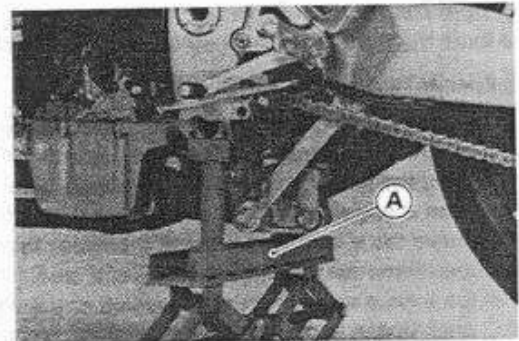

- Remove:
  - Cotter Pin [A]
  - Axle Nut [B]
  - Axle [C]

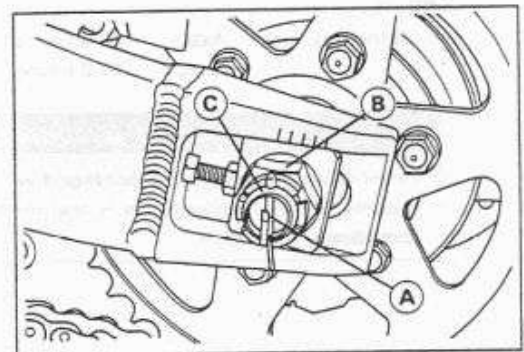

- Remove the drive chain [A] from the rear sprocket toward the left.
- Move the rear wheel back and remove the wheel from the rear caliper.
- Remove the rear wheel.

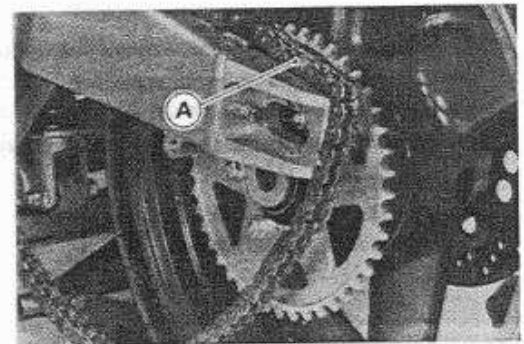

**CAUTION**

Do not lay the wheel on the ground with the disc facing down. This can damage or warp the disc. Place blocks under the wheel so that the disc does not touch the ground.

**Rear Wheel Installation**

- Engage the drive chain with the rear sprocket.
- Install the caliper bracket [A] onto the swingarm stop [B].
- Insert the axle from the right side of the wheel, and tighten the axle nut.

**Torque – Rear Axle Nut: 145 N-m (15.0 kg-m, 110 ft-lb)**

- Adjust the drive chain slack after installation (see Final Drive chapter).
- Check the rear brake.

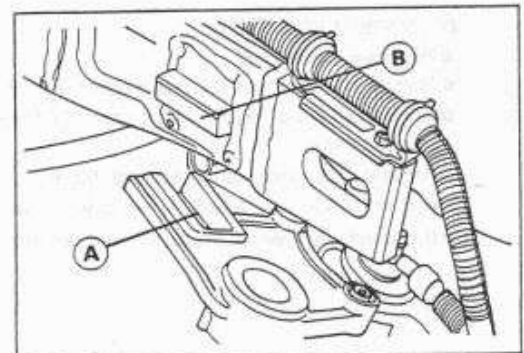

**⚠WARNING**

Do not attempt to drive the motorcycle until a full brake pedal is obtained by pumping the brake pedal until the pads are against the disc. The brake will not function on the first application of the pedal if this is not done.

**Wheel Inspection**

- Raise the front/rear wheel off the ground.

**Special Tool – Jack: 57001-1238**

- Spin the wheel lightly, and check for roughness or binding.
- ★ If roughness or binding is found, replace the hub bearings.
- Inspect the wheel for small cracks, dents, bending, or warp.
- ★ If there is any damage to the wheel, replace the wheel.
- Remove the wheel, and support it without the tire by the axle.
- Measure the rim runout, radial [A] and axial [B], with a dial gauge.
- ★ If rim runout exceeds the service limit, check the hub bearings.
- ★ If the problem is not due to the bearings, replace the wheel.

**Rim Runout**

<b>Service Limit:</b>	<b>Axial</b>	<b>TIR 0.5 mm</b>
	<b>Radial</b>	<b>TIR 0.8 mm</b>

**⚠WARNING**

Never attempt to repair a damaged wheel. If there is any damage besides wheel bearings, the wheel must be replaced to insure safe operational condition.

**Axle Inspection**

- Visually inspect the front and rear axle for damages.
- ★ If the axle is damaged or bent, replace it.
- Measure the axle runout with a dial gauge.
- ★ If axle runout exceeds the service limit, replace the axle.

**Axle Runout/100 mm**

<b>Standard:</b>	<b>TIR 0.05 mm or less</b>
<b>Service Limit:</b>	<b>TIR 0.2 mm</b>

**Balance Inspection**

- Remove the wheel.
- Support the wheel so that it can be spun freely.
- Spin the wheel lightly, and mark [A] the wheel at the top when the wheel stops.
- Repeat this procedure several times. If the wheel stops of its own accord in various positions, it is well balanced.
- ★ If the wheel always stops in one position, adjust the wheel balance.

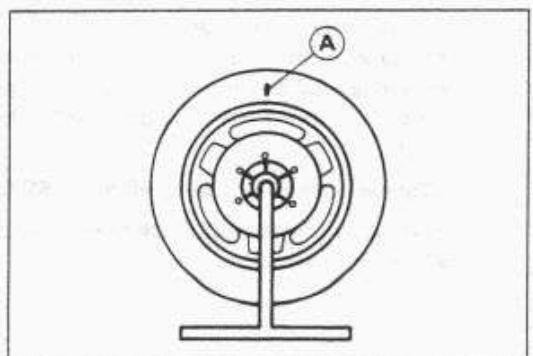
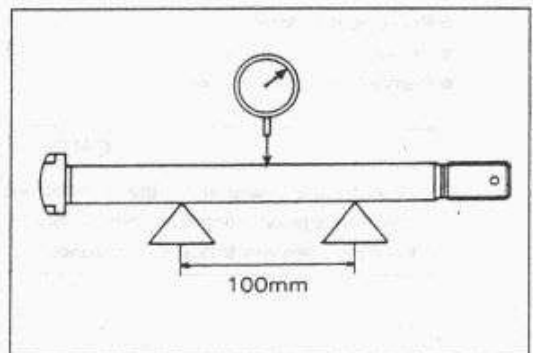
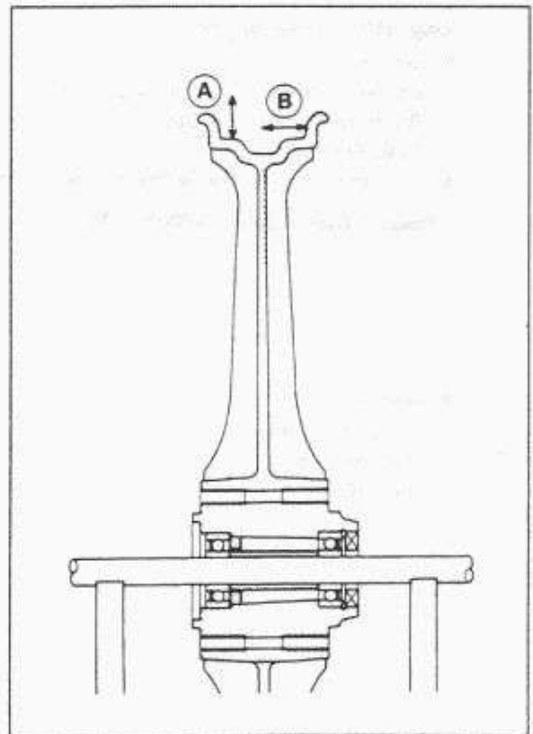



### Balance Adjustment

- If the wheel always stops in one position, provisionally attach a balance weight [A] on the rim at the marking using adhesive tape.
- Rotate the wheel ¼ turn [B], and see whether or not the wheel stops in this position. If it does, the correct balance weight is being used.
- ★ If the wheel rotates and the weight goes up, replace the weight with the next heavier size. If the wheel rotates and the weight goes down, replace the weight with the next lighter size. Repeat these steps until the wheel remains at rest after being rotated ¼ turn.
- Rotate the wheel another ¼ turn and then another ¼ turn to see if the wheel is correctly balanced.
- Repeat the entire procedure as many times as necessary to achieve correct wheel balance.
- Permanently install the balance weight.

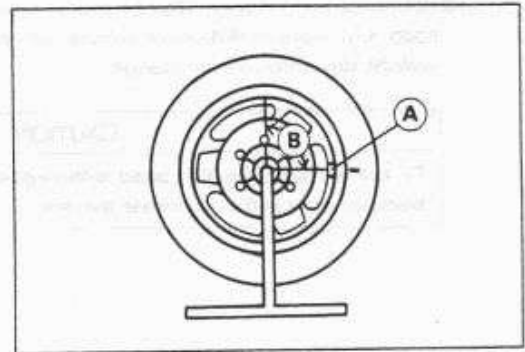

### Balance Weight

Part Number	Weight(grams)
41075-1014	10
41075-1015	20
41075-1016	30

### Balance Weight Removal

(a) When the tire is not on the rim.

- Push the blade portion toward the outside with a regular tip screw driver, and slip the weight off the rim flange.
- Discard the used balance weight.

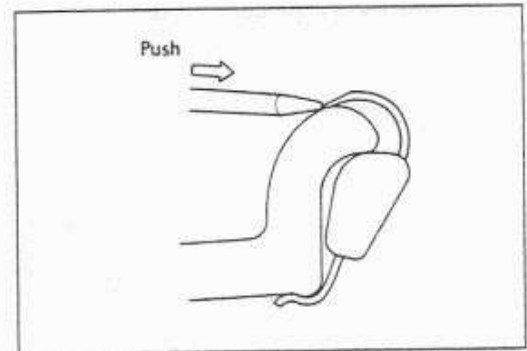

(b) When the tire is on the rim.

- Pry the balance weight off the rim flange using a regular tip screw driver as shown in the figure.
- Insert a tip of the screw driver between the tire bead [A] and weight blade [B] until the end of the tip reaches the end of the weight blade.
- Push the driver grip toward the tire so that the balance weight slips off the rim flange.
- Discard the used balance weight.

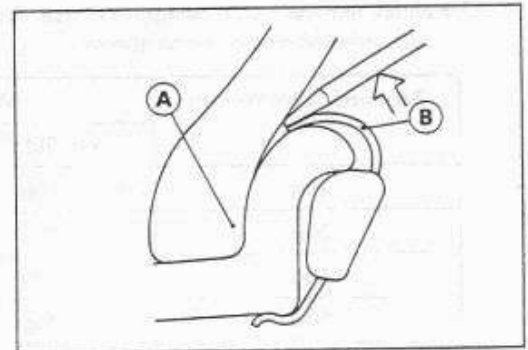

### Balance Weight Installation

- Check if the weight portion has any play on the blade-and-clip plate.
- ★ If it does, discard it.

#### ⚠ WARNING

If the balance weight has any play on the rim flange, the blade and/or clip have been stretched. Replace the loose balance weight. Do not reuse used balance weight.

- Lubricate the balance weight blade, tire bead, and rim flange with a soap and water solution or rubber lubricant. This helps the balance weight slip onto the rim flange.

**CAUTION**

Do not lubricate the tire bead with engine oil or petroleum distillates because they will deteriorate the tire.

- Install the balance on the rim.
  - Slip the weight on the rim flange by pushing or lightly hammering the weight in the direction shown in the figure.
  - Check that the blade and weight seat fully on the rim flange, and that the clip is hooked over the rim ridge and reaches rim flat portion.

**Installing Balance Weight**

(a) Press or lightly hammer the weight in.

(b) Installation completed.

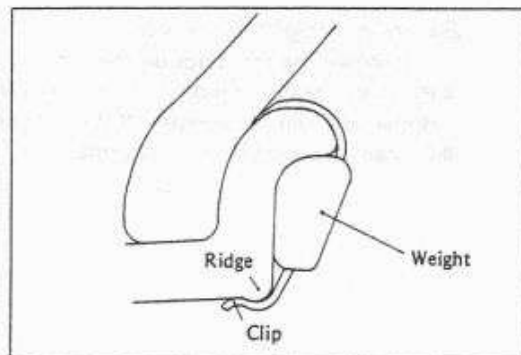
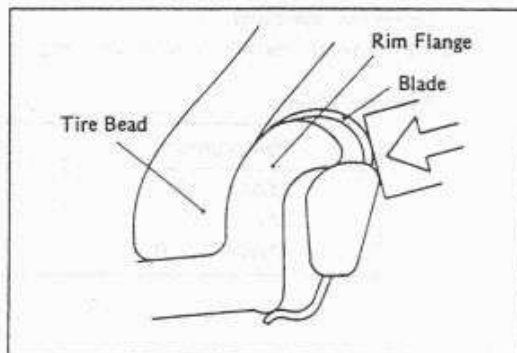

- When required total weight exceeds 20g, install balance weight at both sides of rim flange as shown.

Required Total Weight	Weight Selection	
	One Side [A]	Other Side [B]
20g	10g	10g
30g	20g	10g
40g	20g	20g
50g	30g	20g
60g	30g	30g
70g	20g + 20g	30g
80g	20g + 20g	20g + 20g
90g	20g + 30g	20g + 20g

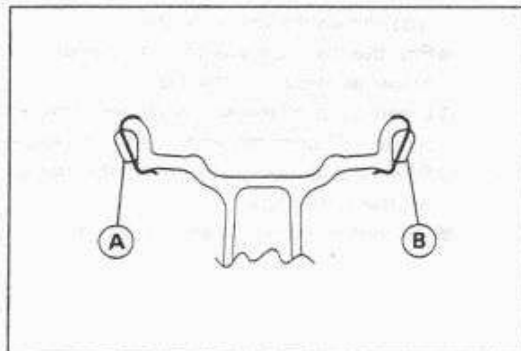

**Tires**

**Air Pressure Inspection/Adjustment**

- Measure the tire air pressure with an air pressure gauge [A] when the tires are cold.
- ★ Adjust the tire air pressure according to the specifications if necessary.

**Air Pressure (when cold)**

**ZX750N**

Front	Up to 106 kg (233 lb) load	230 kPa (2.3 kg/cm <sup>2</sup> , 33 psi)
Rear	Up to 106 kg (233 lb) load	250 kPa (2.5 kg/cm <sup>2</sup> , 36 psi)

**ZX750P**

Front	Up to 183 kg (404 lb) load	250 kPa (2.5 kg/cm <sup>2</sup> , 36 psi)
Rear	Up to 183 kg (404 lb) load	290 kPa (2.9 kg/cm <sup>2</sup> , 41 psi)

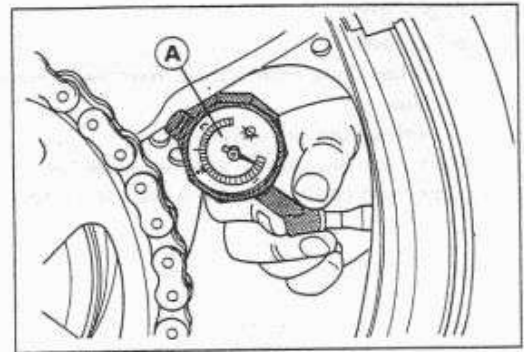

**Tire Inspection**

- Remove any imbedded stones or other foreign particles from the tread.
- Visually inspect the tire for cracks and cuts, replacing the tire in case of damage. Swelling or high spots indicate internal damage, requiring tire replacement.
- Measure the tread depth at the center of the tread with a depth gauge [A]. Since the tire may wear unevenly, take measurement at several places.
- ★ If any measurement is less than the service limit, replace the tire.

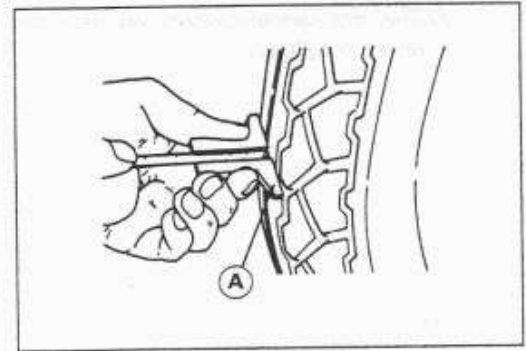

**Tread Depth**

**Front:**

**Standard:** 4.4 mm (DUNLOP)  
 Crown: 3.6 mm, Shoulder: 3 mm (MICHELIN)  
 3.4 mm (BRIDGESTONE)

**Service Limit:** 1 mm

**Rear:**

**Standard:** 5.4 mm (DUNLOP)  
 Crown: 6.3 mm, Shoulder: 5.4 mm (MICHELIN)  
 5.8 mm (BRIDGESTONE)

**Service Limit:** 2 mm (Up to 130 km/h)  
 3 mm (Over 130 km/h)

**⚠ WARNING**

To ensure safe handling and stability, use only the recommended standard tires for replacement, inflated to the standard pressure.

**NOTE**

- Check and balance the wheel when a tire is replaced with a new one.

## Tire Removal

- Remove:
  - Wheel (see Front Wheel Removal, Rear Wheel Removal)
  - Disc (s)
  - Valve Core (let out the air)
- To maintain wheel balance, mark the valve stem position [A] on the tire with chalk so that the tire can be reinstalled in the same position.

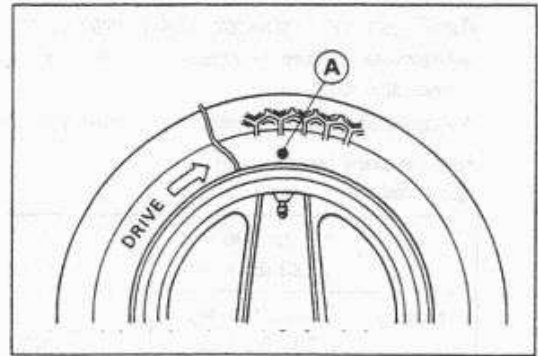

- Lubricate the tire beads and rim flanges on both sides with a soap and water solution or rubber lubricant. This helps the tire beads slip off the rim flanges.

### CAUTION

Never lubricate with engine oil or petroleum distillates because they will deteriorate the tire.

- Remove the tire from the rim using a suitable commercially available tire changer.

### NOTE

- The tires cannot be removed with hand tools because they fit the rims too tightly.

## Tire Installation

- Inspect the rim and tire, and replace them if necessary.
- Clean the sealing surfaces of the rim and tire, and smooth the sealing surfaces of the rim with a fine emery cloth if necessary.
- Remove the air valve and discard it.

### CAUTION

Replace the air valve whenever the tire is replaced.  
Do not reuse the air valve.

- Install a new valve in the rim.
- Remove the valve cap, lubricate the stem seal [A] with a soap and water solution or rubber lubricant, and pull the valve stem through the rim from the inside out until it snaps into place.

### CAUTION

Do not use engine oil or petroleum distillates to lubricate the stem because they will deteriorate the rubber.

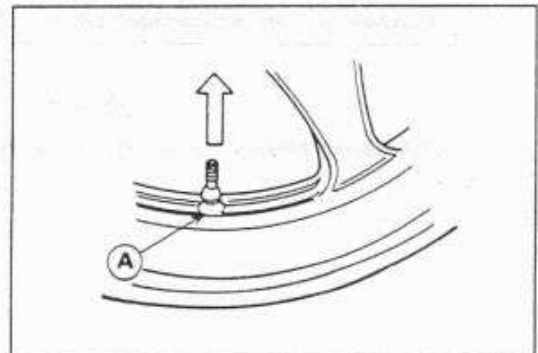

- |                |                |                  |
|----------------|----------------|------------------|
| [A] Valve Cap  | [C] Stem Seal  | [E] Valve Seat   |
| [B] Valve Core | [D] Valve Stem | [F] Valve Opened |

- Apply a soap and water solution, or rubber lubricant to the rim flange and tire beads.

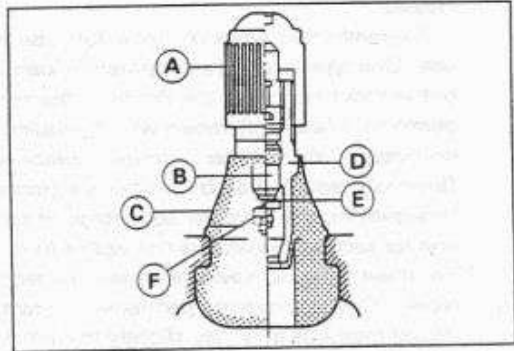

- Check the tire rotation mark on the front and rear tires and install them on the rim accordingly.

**NOTE**

○ The direction of the tire rotation [A] is shown by an arrow [B] on the tire sidewall.

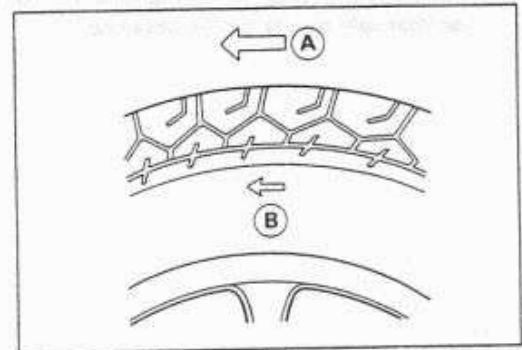

- Position the tire on the rim so that the valve is at the tire balance mark (the chalk mark made during removal, or the yellow paint mark on a new tire).
- Install the tire on the rim using a suitable commercially available tire changer.
- Lubricate the tire beads and rim flanges with a soap and water solution or rubber lubricant to help seat the tire beads in the sealing surfaces of the rim while inflating the tire.
- Center the rim in the tire beads, and inflate the tire with compressed air until the tire beads seat in the sealing surfaces.

**▲WARNING**

Be sure to install the valve core whenever inflating the tire, and do not inflate the tire to more than 400 kPa(4.0 kg/cm<sup>2</sup>, 57 psi). Overinflation can explode the tire with possibility of injury and loss of life.

- Check to see that the rim lines [A] on both sides of the tire sidewalls are parallel with the rim flanges.
- ★ If the rim flanges and tire sidewall rim lines are not parallel, remove the valve core.
- Lubricate the rim flanges and tire beads.
- Install the valve core and inflate the tire again.
- After the tire beads seat in the rim flanges, check for air leaks.
- Inflate the tire slightly above standard inflation.
- Use a soap and water solution or submerge the tire, and check for bubbles that would indicate leakage.
- Adjust the air pressure to the specified pressure.
- Install the brake disc(s) so that the disc rotation mark aligns with the tire rotation.
- Adjust the wheel balance.

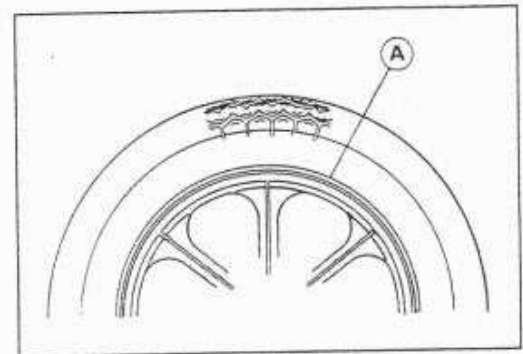

### *Repair*

Currently two types of repair for tubeless tires have come into wide use. One type is called a temporary (external) repair which can be carried out without removing the tire from the rim, and the other type is called permanent (internal) repair which requires tire removal. It is generally understood that higher running durability is obtained by permanent (internal) repairs than by temporary (external) ones. Also, permanent (internal) repairs have the advantage of permitting a thorough examination for secondary damage not visible from external inspection of the tire. For these reasons, Kawasaki does not recommend temporary (external) repair. Only appropriate permanent (internal) repairs are recommended. Repair methods may vary slightly from make to make. Follow the repair methods indicated by the manufacturer of the repair tools and materials so that safe results can be obtained.

## Hub Bearing

### Hub Bearing Removal

- Remove the wheel, and take out the following.
  - Collars
  - Coupling (out of rear hub)
  - Grease Seals
  - Circlips

**Special Tool – Inside Circlip Pliers: 57001-143 [A]**

Speedometer Gear Drive [B] (out of front hub)

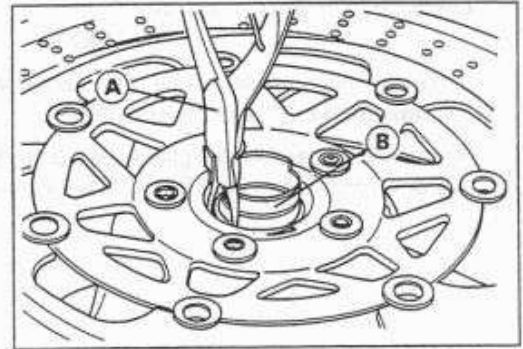

- Take the bearings [A] out of the hub.

#### CAUTION

Do not lay the wheel on the ground with the disc facing down. This can damage or warp the disc. Place blocks under the wheel so that the disc does not touch the ground.

**Special Tool – Bearing Remover Shaft: 57001-1265 [B]**

**Bearing Remover Head,  $\Phi 25 \times \Phi 28$ : 57001-1346 [C]**

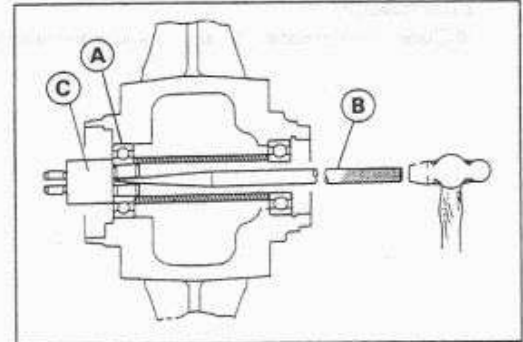

### Hub Bearing Installation

- Before installing the wheel bearings, blow any dirt or foreign particles out of the hub with compressed air to prevent contamination of the bearings.
- Replace the bearings with new ones.
- Press in the bearings until they are bottomed.

**Special Tool – Bearing Driver Set: 57001-1129 [A]**

#### NOTE

- Install the bearings so that the marked side faces out.

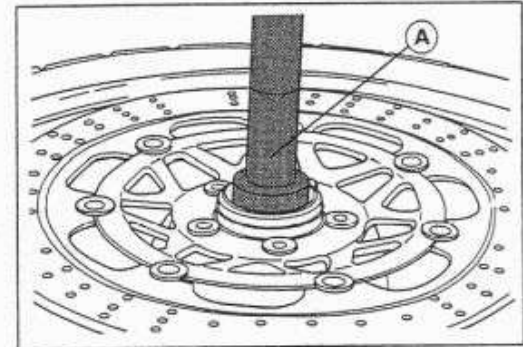

- Replace the circlips with new ones.

**Special Tool – Inside Circlip Pliers: 57001-143**

- Replace the grease seals with new ones.
- Press in the grease seals so that seal surface is flush with the end of the hole.
- Apply high temperature grease to the grease seal lips.

**Special Tool – Bearing Driver Set: 57001-1129 [A]**

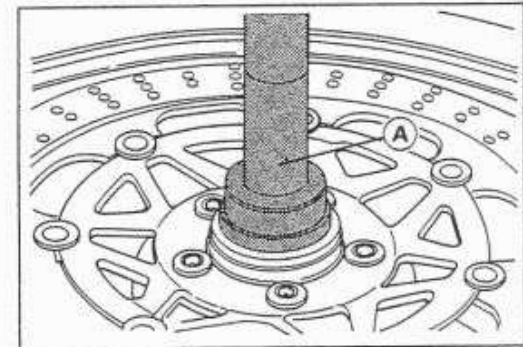

### Hub Bearing Inspection

#### NOTE

- It is not necessary to remove any bearings for inspection. If any bearings are removed, they will need to be replaced with new ones.

- Spin it by hand to check its condition.
- ★ If it is noisy, does not spin smoothly, or has any rough spots, it must be replaced.
- Examine the bearing seal for tears or leakage.
- ★ If the seal is torn or is leaking, replace the bearing.

## Speedometer Gear Housing

### Disassembly and Assembly

#### NOTE

- It is recommended that the assembly be replaced rather than attempting to repair the components.
- Install the speedometer gear housing so that it fits in the speedometer gear drive notches (see Front Wheel Installation).

### Lubrication

- Clean and grease [A] the speedometer gear housing [B].

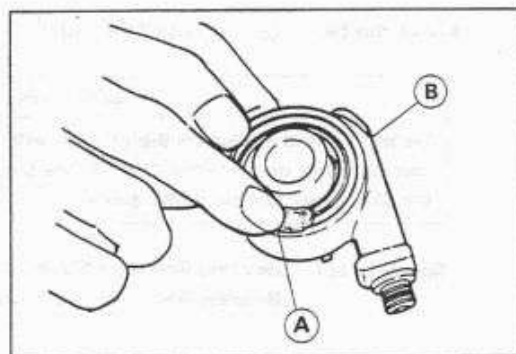



# Final Drive

## Table of Contents

Exploded View .....	10-2
Specifications .....	10-3
Drive Chain.....	10-4
Slack Inspection.....	10-4
Slack Adjustment.....	10-4
Wheel Alignment Inspection Adjustment .....	10-4
Drive Chain Wear Inspection.....	10-5
Lubrication .....	10-5
Drive Chain Removal.....	10-6
Drive Chain Installation .....	10-6
Chain Guard .....	10-7
Chain Guard Removal .....	10-7
Chain Guard Installation.....	10-7
Sprocket, Coupling .....	10-8
Engine Sprocket Removal .....	10-8
Engine Sprocket Installation.....	10-8
Rear Sprocket Removal .....	10-9
Rear Sprocket Installation.....	10-9
Sprocket Wear Inspection .....	10-9
Rear Sprocket Warp Inspection.....	10-9
Coupling Bearing Removal .....	10-10
Coupling Bearing Installation.....	10-10
Coupling Bearing Inspection and Lubrication.....	10-10

## 10-2 FINAL DRIVE

### Exploded View

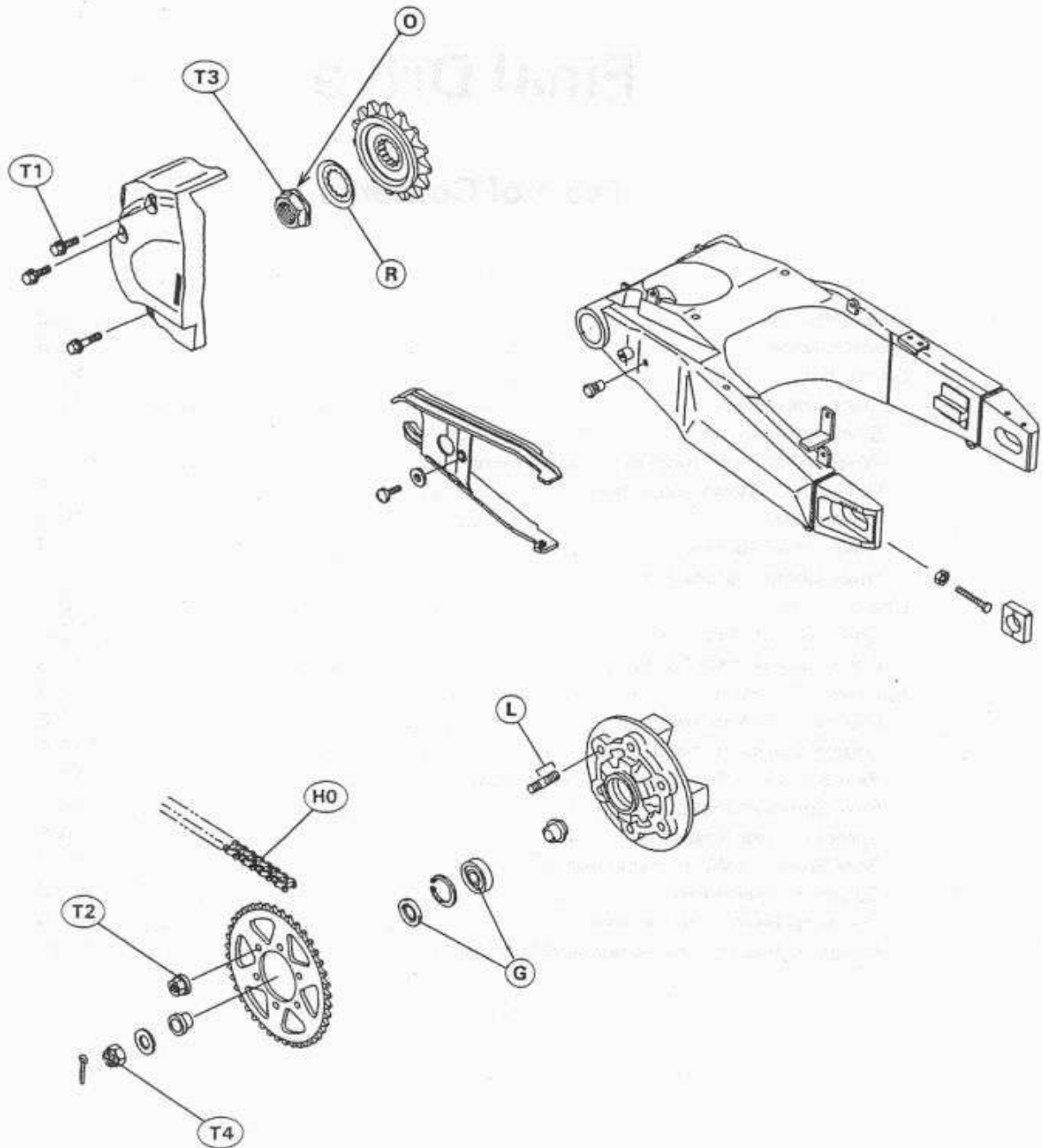

G : Apply grease.  
HO: Apply heavy oil.  
L : Apply a non-permanent locking agent.  
O : Apply oil.  
R : Replacement Parts

T1 : 9.8 N-m (1.0 kg-m, 87 in-lb)  
T2 : 74 N-m (7.5 kg-m, 54 ft-lb)  
T3 : 125 N-m (13.0 kg-m, 94 ft-lb)  
T4 : 145 N-m (15.0 kg-m, 110 ft-lb)

## Specifications

Item	Standard	Service Limit
<b>Drive Chain:</b>		
Standard chain		
Make	RK	---
Type	RK525ROZ2, Endless	---
Link	ZX750N ZX750P	---
108 links		---
110 links		---
Chain slack	30 ~ 35 mm	Too tight: less than 30 mm Too loose: more than 40 mm
20-link length	317.5 ~ 318.2 mm	323 mm
<b>Sprockets:</b>		
Rear sprocket warp	TIR 0.4 mm or less	TIR 0.5 mm

Special Tool – Inside Circlip Pliers: 57001-143  
 Bearing Driver Set: 57001-1129  
 Jack: 57001-1238

## Drive Chain

## Slack Inspection

## NOTE

- Check the slack with the motorcycle setting on its side stand.
  - Clean the chain if it is dirty, and lubricate it if it appears dry.
  - Check the wheel alignment (see Wheel Alignment Inspection).
  - Rotate the rear wheel to find the position where the chain is tightest.
  - Measure the vertical movement (chain slack [A]) midway between the sprockets.
- ★ If the chain slack exceeds the standard, adjust it.

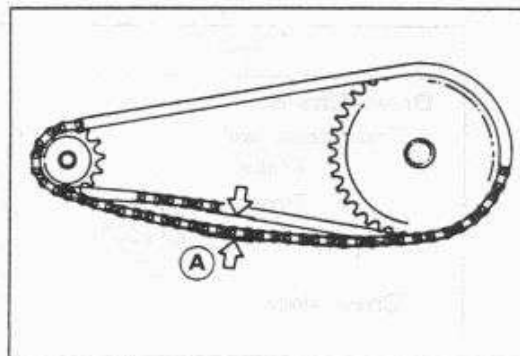

## Chain Slack

Standard:	30 ~ 35 mm
Too Tight:	less than 30 mm
Too Loose:	more than 40 mm

## Slack Adjustment

- Remove the cotter pin [A], and loosen the axle nut [B].
- Loosen the both chain adjuster locknuts [C].
- ★ If the chain is too loose, turn out the left and right chain adjuster [D] evenly.
- ★ If the chain is too tight, turn in the left and right chain adjusters evenly, and kick the wheel forward.
- Turn both chain adjusters evenly until the drive chain has the correct amount of slack. To keep the chain and wheel properly aligned, the notch [E] on the left wheel alignment indicator [F] should align with the same swingarm mark or position [G] that the right indicator notch aligns with.

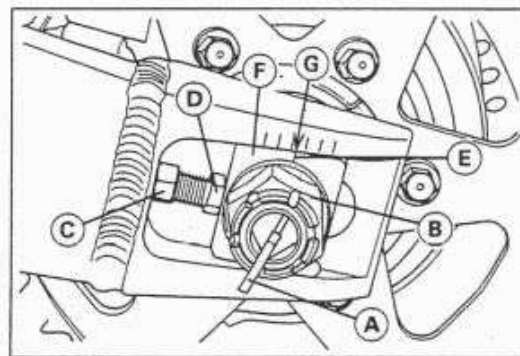

## ▲WARNING

Misalignment of the wheel will result in abnormal wear and may result in an unsafe riding condition.

- Tighten both chain adjuster locknuts securely.
- Tighten the axle nut.  
Torque – Rear Axle Nut: 145 N-m (15.0 kg-m, 110 ft-lb)
- Turn the wheel, measure the chain slack again at the tightest position, and readjust if necessary.
- Insert a new cotter pin and spread its ends.

## Wheel Alignment Inspection Adjustment

- Check that the notch [A] on the left alignment indicator [B] aligns with the same swingarm mark or position [C] that the right alignment indicator notch aligns with.
- ★ If they are not, adjust the chain slack and align the wheel alignment (see Slack Adjustment).

## NOTE

- Wheel alignment can be also be checked using the straightedge or string method.

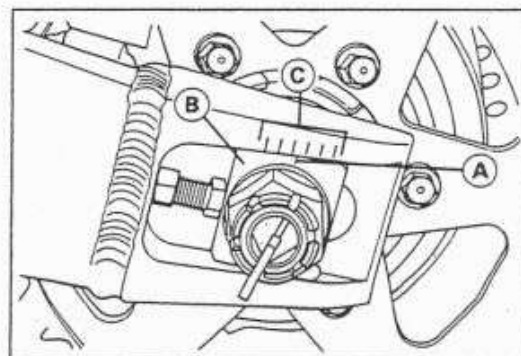

**⚠ WARNING**

Misalignment of the wheel will result in abnormal wear, and may result in an unsafe riding condition.

**Drive Chain Wear Inspection**

- Remove:
  - Chain Cover
- Rotate the rear wheel to inspect the drive chain for damaged rollers, and loose pins and links.
- ★ If there is any irregularity, replace the drive chain.
- ★ Lubricate the drive chain if it appears dry.
- Stretch the chain taut by hanging a 98 N (10 kg, 20 lb) weight [A] on the chain.
- Measure the length of 20 links [B] on the straight part [C] of the chain from the pin center of the 1st pin to the pin center of the 21st pin. Since the chain may wear unevenly, take measurements at several places.
- ★ If any measurements exceed the service limit, replace the chain. Also, replace the front and rear sprockets when the drive chain is replaced.

**Drive Chain 20-link Length**

Standard:	317.5 ~ 318.2 mm
Service Limit:	323 mm

**⚠ WARNING**

If the drive chain wear exceeds the service limit, replace the chain or an unsafe riding condition may result. A chain that breaks or jumps off the sprockets could snag on the engine sprocket or lock the rear wheel, severely damaging the motorcycle and causing it to go out of control.

For safety, use only the standard chain. It is an endless type and should not be cut for installation.

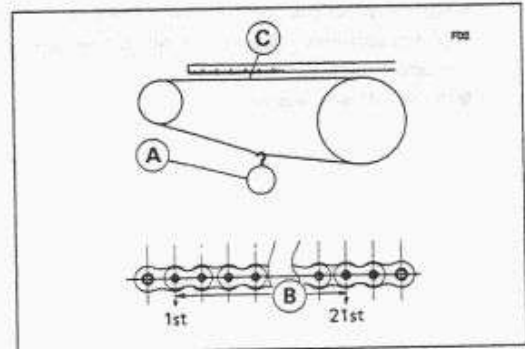
**Lubrication**

- ★ If a special lubricant is not available, a heavy oil such as SAE 90 is preferred to a lighter oil because it will stay on the chain longer and provide better lubrication.
- ★ If the chain appears especially dirty, clean it before lubrication.

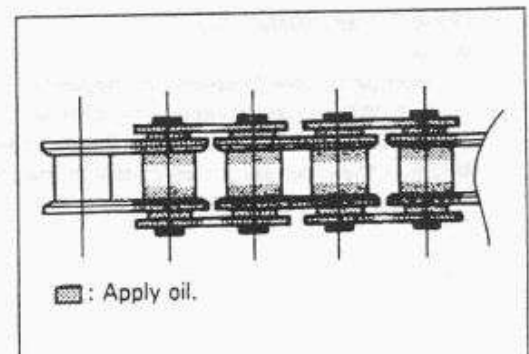

**CAUTION**

The O-rings between the side plates seal in the lubricant between the pin and the bushing. To avoid damaging the O-rings and resultant loss of lubricant, observe the following rules.

Use only kerosene or diesel oil for cleaning an O-ring drive chain.

Any other cleaning solution such as gasoline or trichloroethylene will cause deterioration and swelling of the O-ring.

Immediately blow the chain dry with compressed air after cleaning. Complete cleaning and drying the chain within 10 minutes.

- Apply oil to the sides of the rollers so that oil will penetrate to the rollers and bushings. Apply the oil to the O-rings so that the O-rings will be coated with oil.
- Wipe off any excess oil.

**Drive Chain Removal**

- Remove:
  - Engine Sprocket (see Engine Sprocket Removal)
  - Rear Wheel (see Wheels/Tires chapter)
  - Chain Cover Screws [A]
  - Chain Cover [B]
  - Swingarm (see Suspension chapter)

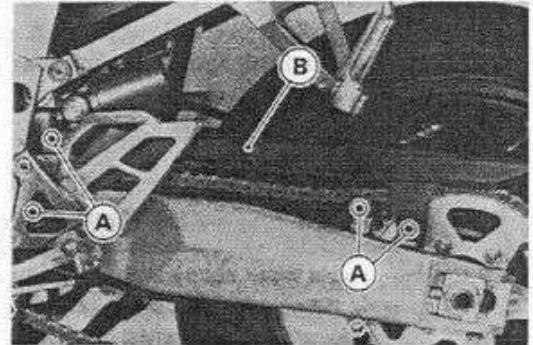

- Remove the drive chain [A] from the engine output shaft [B].

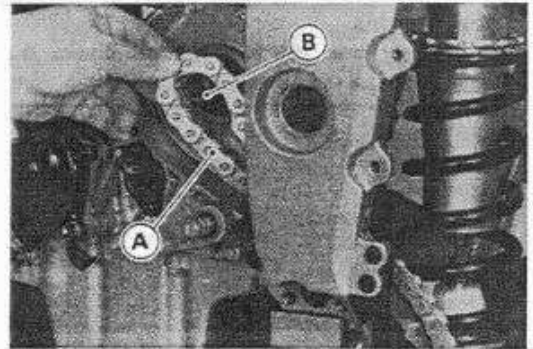
**Drive Chain Installation**

- Install:
  - Swingarm (see Suspension chapter)
  - Rear Wheel (see Wheels/Tires chapter)
  - Engine Sprocket (see Engine Sprocket Removal)
- Adjust the chain slack after installing the chain (see Slack Adjustment).

## Chain Guard

### Chain Guard Removal

- Remove:
  - Footpeg Bracket Bolts [A]
  - Chain Cover [B]

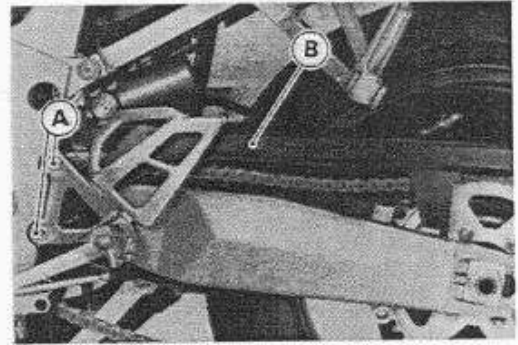

- Remove the screw [A], and pull [B] the rear parts of the chain guard [C] to clear the stoppers.
- Pull out the chain guard to the rear.

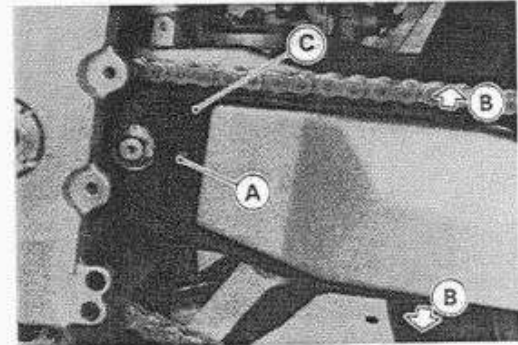

### Chain Guard Installation

- Tap lightly the rear parts [A] of the chain guard with a plastic mallet and install it.
- Fit the projections [B] on the chain guard into the holes in the swingarm.
- Check the drive chain slack after installation (see Slack Inspection).

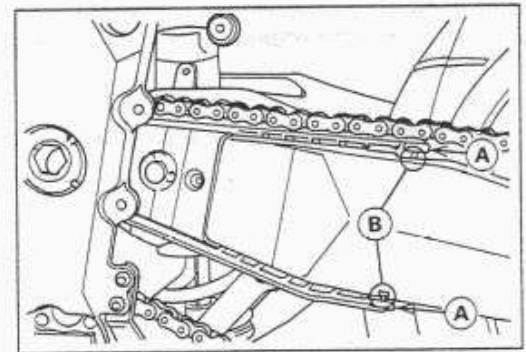

## Sprocket, Coupling

### Engine Sprocket Removal

● Remove:

- Lower Fairings (see Frame Chapter)
- Clutch Slave Cylinder (see Clutch chapter)
- Engine Sprocket Cover Bolts [A]
- Engine Sprocket Cover [B]
- Chain Cover

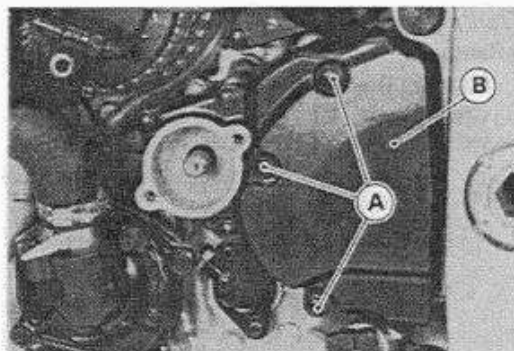

- Slave Cylinder Cover Bolts [A]
- Slave Cylinder Cover [B]

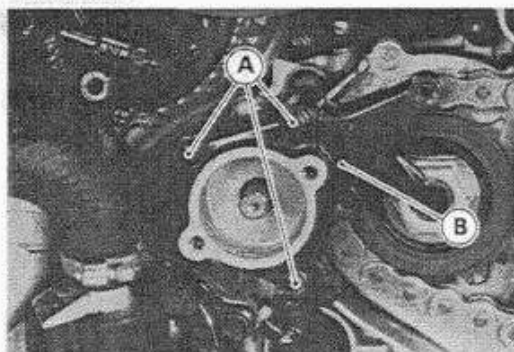

- Flatten out the bended washer [A].
- Remove the engine sprocket nut [B] and washer.

### NOTE

- When loosening the engine sprocket nut, hold the rear brake on.

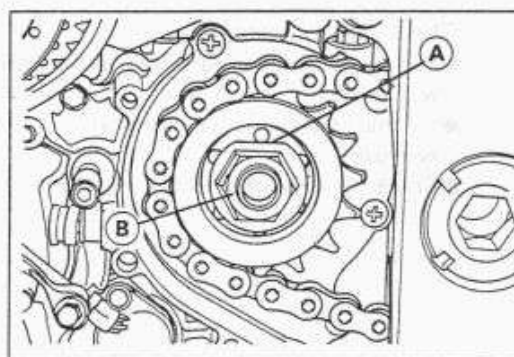

- Using the jack, raise the rear wheel off the ground.

**Special Tool – Jack: 57001-1238**

- Loosen the drive chain (see Slack Adjustment).
- Pull the engine sprocket [A] off the output shaft [B] along with the chain.
- Remove the engine sprocket.

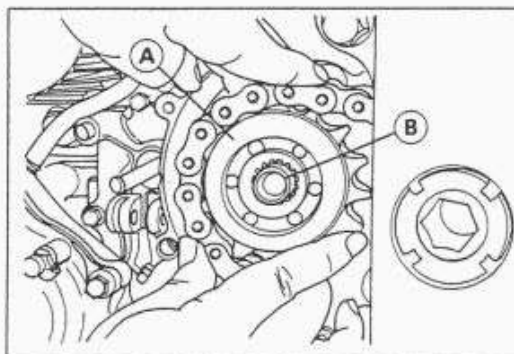

### Engine Sprocket Installation

- Replace the sprocket washer and axle cotter pin.
- Install the engine sprocket onto the output shaft with the drive chain engaged.
- Either side of the sprocket may be faced out.
- Apply oil to the threads of the output shaft and the seating surface of the engine sprocket nut.
- After torquing the engine sprocket nut [A], bend the one side [B] of the washer over the nut.

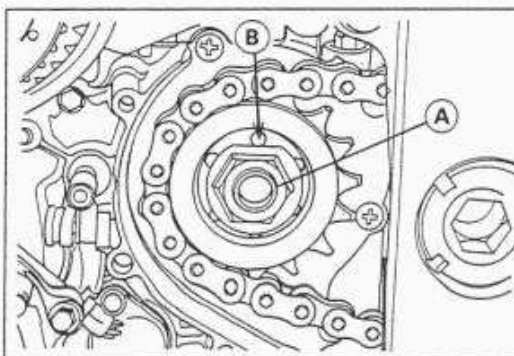



**NOTE**

○ Tighten the nut while applying the rear brake.

**Torque – Engine Sprocket Nut : 125 N-m (13.0 kg-m, 94 ft-lb)**

- Adjust the drive chain slack after installing the sprocket (see Slack Adjustment).

**Rear Sprocket Removal**

- Remove the rear wheel (see Wheel/Tires chapter).

**CAUTION**

Do not lay the wheel on the ground with the disc facing down. This can damage or warp the disc. Place blocks under the wheel so that the disc does not touch the ground.

- Remove the rear sprocket nuts [A].
- Remove the rear sprocket [B].

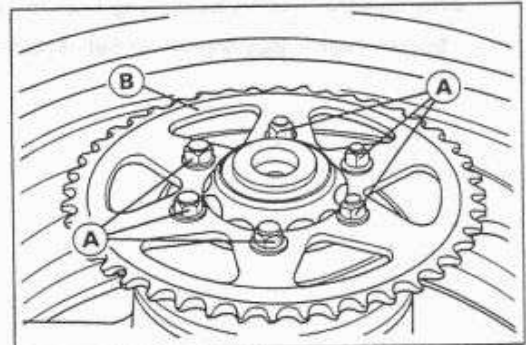
**Rear Sprocket Installation**

- Install the sprocket facing the tooth number marking [A] outward.
- Tighten the rear sprocket nuts.

**Torque – Rear Sprocket Nut : 74 N-m (7.5 kg-m, 54 ft-lb)**

- Install the rear wheel (see Wheels/ Tires chapter).

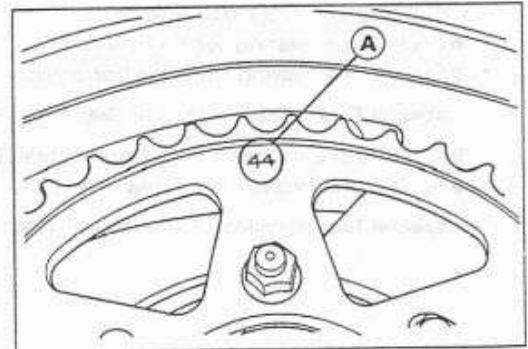
**Sprocket Wear Inspection**

- Visually inspect the engine and rear sprocket teeth for wear and damage.

★ If the teeth are worn as illustrated, replace the sprocket, and inspect the drive chain wear (see Drive Chain Wear Inspection).

[A] Worn Tooth (Engine Sprocket)

[B] Worn Tooth (Rear Sprocket)

[C] Direction of Rotation

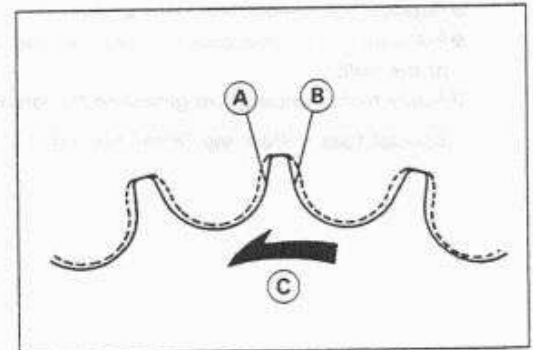
**NOTE**

○ If a sprocket requires replacement, the chain is probably worn also. When replacing a sprocket, inspect the chain.

**Rear Sprocket Warp Inspection**

- Raise the rear wheel off the ground (see Wheels/Tires chapter) so that it will turn freely.
- Set a dial gauge [A] against the rear sprocket [B] near the teeth as shown, and rotate [C] the rear wheel to measure the sprocket runout (warp). The difference between the highest and lowest dial gauge readings is the amount of runout (warp).
- ★ If the runout exceeds the service limit, replace the rear sprocket.

**Rear Sprocket Warp**

**Standard: TIR 0.4 mm or less**

**Service Limit: TIR 0.5 mm**

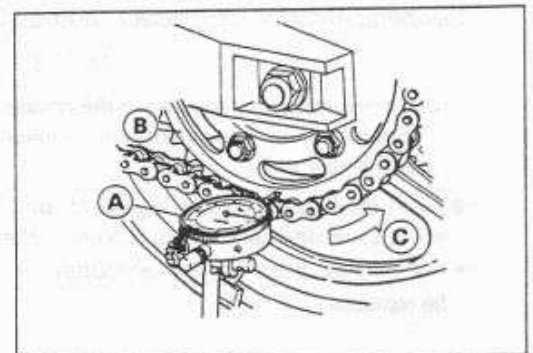

### Coupling Bearing Removal

- Remove:
  - Coupling
  - Grease Seal
  - Circlip [A]

Special Tool – Inside Circlip Pliers: 57001-143 [B]

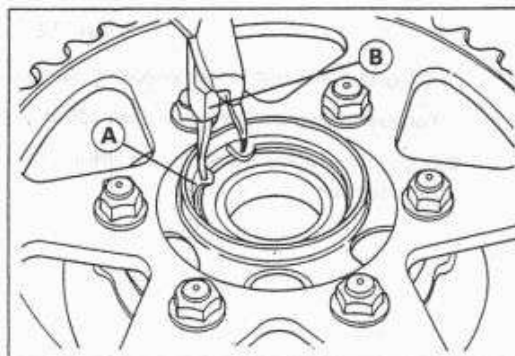

- Remove the bearing by tapping from the wheel side.

Special Tool – Bearing Driver Set: 57001-1129 [A]

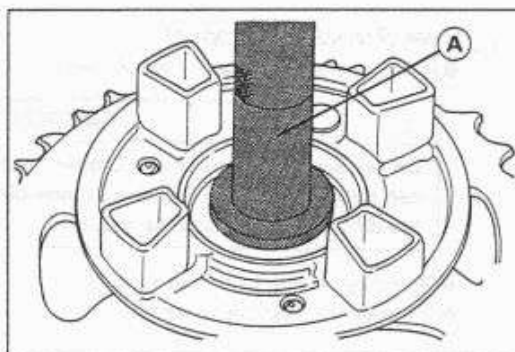

### Coupling Bearing Installation

- Replace the bearing with a new one.
- Press in the bearing until it is bottomed.

Special Tool – Bearing Driver Set: 57001-1129 [A]

- Pack the bearing with high temperature grease.
- Replace the circlip with a new one.

Special Tool – Inside Circlip Pliers: 57001-143

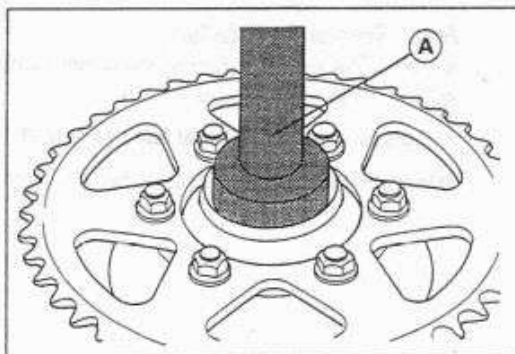

- Replace the grease seal with a new one.
- Press in the grease seal so that the seal surface is flush with the end of the hole.
- Apply high temperature grease to the grease seal lips.

Special Tool – Bearing Driver Set: 57001-1129 [A]

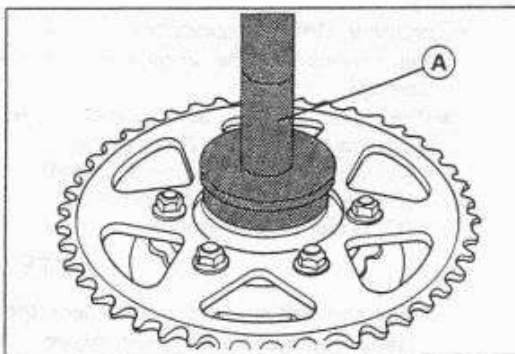

### Coupling Bearing Inspection and Lubrication

#### NOTE

○ It is not necessary to remove the coupling bearing for inspection and lubrication. If the bearing is removed, it will need to be replaced with a new one.

- Wash the bearing with a high flash-point solvent, dry it (do not spin it while it is dry), and oil it. Spin it by hand to check its condition.
- ★ If it is noisy, does not spin smoothly, or has any rough spots, it must be replaced.

- Pack the bearing with good quality bearing grease. Turn the bearing around by hand a few times to make sure the grease is distributed uniformly inside the bearing.

It is recommended that you use the correct oil grade for your vehicle. The oil grade is listed in the owner's manual. The oil grade is also listed on the oil filler cap. The oil grade is also listed on the dipstick. The oil grade is also listed on the oil filter. The oil grade is also listed on the oil pan. The oil grade is also listed on the oil pump. The oil grade is also listed on the oil sump. The oil grade is also listed on the oil separator. The oil grade is also listed on the oil cooler. The oil grade is also listed on the oil filter housing. The oil grade is also listed on the oil filter element. The oil grade is also listed on the oil filter gasket. The oil grade is also listed on the oil filter seal. The oil grade is also listed on the oil filter cap. The oil grade is also listed on the oil filter base. The oil grade is also listed on the oil filter bracket. The oil grade is also listed on the oil filter support. The oil grade is also listed on the oil filter housing cover. The oil grade is also listed on the oil filter housing gasket. The oil grade is also listed on the oil filter housing seal. The oil grade is also listed on the oil filter housing cap. The oil grade is also listed on the oil filter housing base. The oil grade is also listed on the oil filter housing bracket. The oil grade is also listed on the oil filter housing support. The oil grade is also listed on the oil filter housing cover gasket. The oil grade is also listed on the oil filter housing cover seal. The oil grade is also listed on the oil filter housing cover cap. The oil grade is also listed on the oil filter housing cover base. The oil grade is also listed on the oil filter housing cover bracket. The oil grade is also listed on the oil filter housing cover support. The oil grade is also listed on the oil filter housing cover gasket seal. The oil grade is also listed on the oil filter housing cover seal cap. The oil grade is also listed on the oil filter housing cover seal base. The oil grade is also listed on the oil filter housing cover seal bracket. The oil grade is also listed on the oil filter housing cover seal support.

# Brakes

## Table of Contents

Exploded View .....	11-2	Front Master Cylinder Removal .....	11-12
Specifications .....	11-4	Front Master Cylinder Installation .....	11-12
Brake Pedal .....	11-5	Rear Master Cylinder Removal .....	11-12
Brake Pedal Position Inspection .....	11-5	Rear Master Cylinder Installation .....	11-13
Brake Pedal Position Adjustment .....	11-5	Front Master Cylinder Disassembly .....	11-13
Calipers .....	11-6	Rear Master Cylinder Disassembly .....	11-13
Caliper Removal .....	11-6	Master Cylinder Assembly .....	11-14
Caliper Installation .....	11-6	Master Cylinder Inspection	
Front Caliper Disassembly .....	11-6	(Visual Inspection) .....	11-14
Rear Caliper Disassembly .....	11-7	Brake Disc .....	11-15
Caliper Assembly .....	11-8	Brake Disc Removal .....	11-15
Brake Pads .....	11-9	Brake Disc Installation .....	11-15
Front Brake Pad Removal (ZX750N) .....	11-9	Brake Disc Wear .....	11-15
Front Brake Pad Installation (ZX750N) .....	11-9	Brake Disc Warp .....	11-15
Front Brake Pad Removal (ZX750P) .....	11-9	Brake Fluid .....	11-16
Front Brake Pad Installation (ZX750P) .....	11-10	Level Inspection .....	11-16
Rear Brake Pad Removal (ZX750N) .....	11-10	Brake Fluid Change .....	11-16
Rear Brake Pad Installation (ZX750N) .....	11-10	Bleeding the Brake Line .....	11-17
Rear Brake Pad Removal (ZX750P) .....	11-11	Brake Hose .....	11-19
Rear Brake Pad Installation (ZX750P) .....	11-11	Brake Hose Removal/Installation .....	11-19
Lining Wear .....	11-11	Brake Hose Inspection .....	11-19
Master Cylinder .....	11-12		

# 11-2 BRAKES

## Exploded View

- B: Apply brake fluid.
- G: Apply grease.
- L: Apply a non-permanent locking agent.
- R: Replacement Parts
- S: Follow the specific tightening sequence.
- Si: Apply silicone grease (ex. PBC grease).

- T1: 1.0 N-m (0.10 kg-m, 9 in-lb)
- T2: 1.5 N-m (0.15 kg-m, 13 in-lb)
- T3: 2.5 N-m (0.25 kg-m, 22 in-lb)
- T4: 5.4 N-m (0.55 kg-m, 48 in-lb)
- T5: 5.9 N-m (0.60 kg-m, 52 in-lb)
- T6: 6.9 N-m (0.70 kg-m, 61 in-lb)
- T7: 7.8 N-m (0.80 kg-m, 69 in-lb)
- T8: 11 N-m (1.1 kg-m, 95 in-lb)
- T9: 18 N-m (1.8 kg-m, 13.0 ft-lb)
- T10: 21 N-m (2.1 kg-m, 15.0 ft-lb)
- T11: 23 N-m (2.3 kg-m, 16.5 ft-lb)
- T12: 25 N-m (2.5 kg-m, 18.0 ft-lb)
- T13: 29 N-m (3.0 kg-m, 22 ft-lb)
- T14: 32 N-m (3.3 kg-m, 24 ft-lb)
- T15: 34 N-m (3.5 kg-m, 25 ft-lb)
- T16: 2.9 N-m (0.30 kg-m, 26 in-lb)

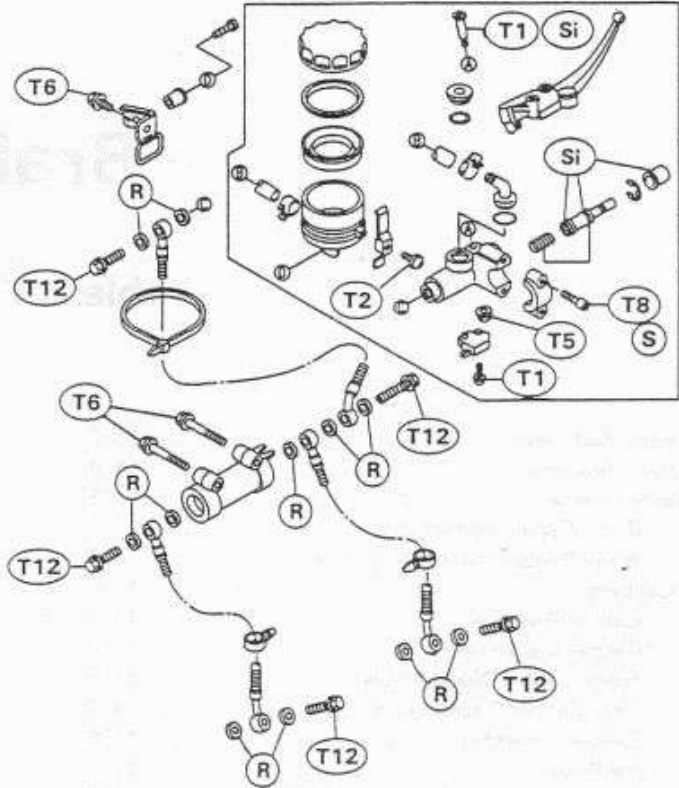

ZX750-N :

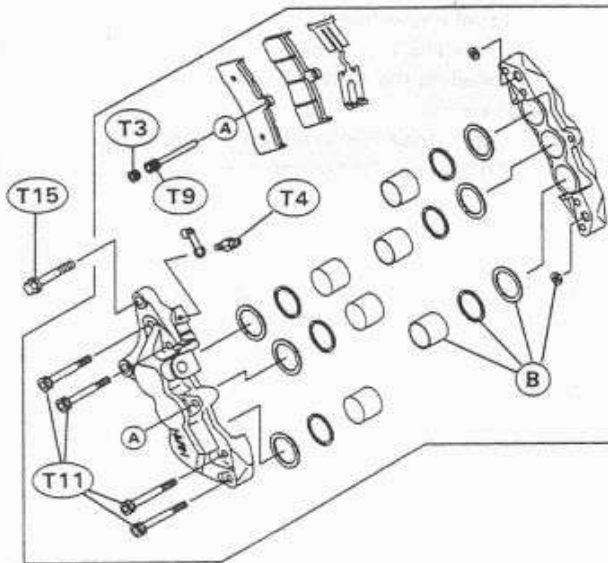

ZX750-P :

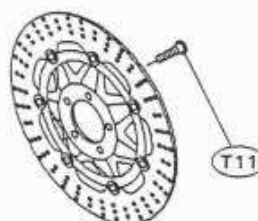
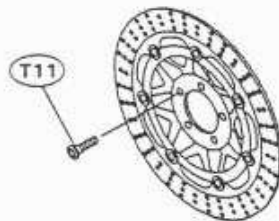
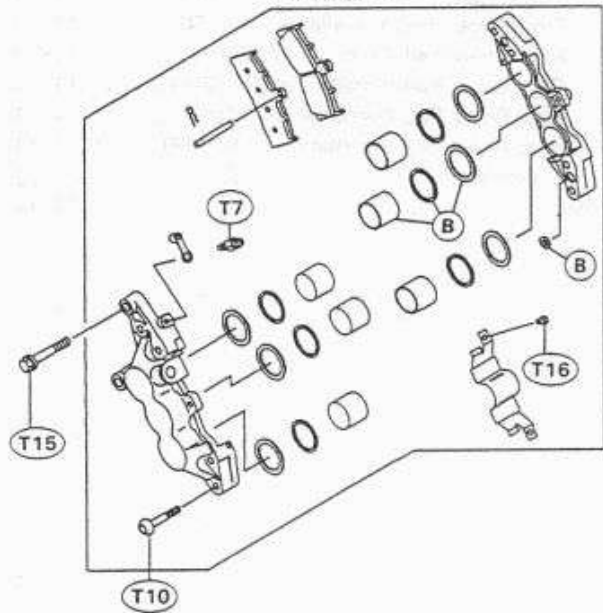

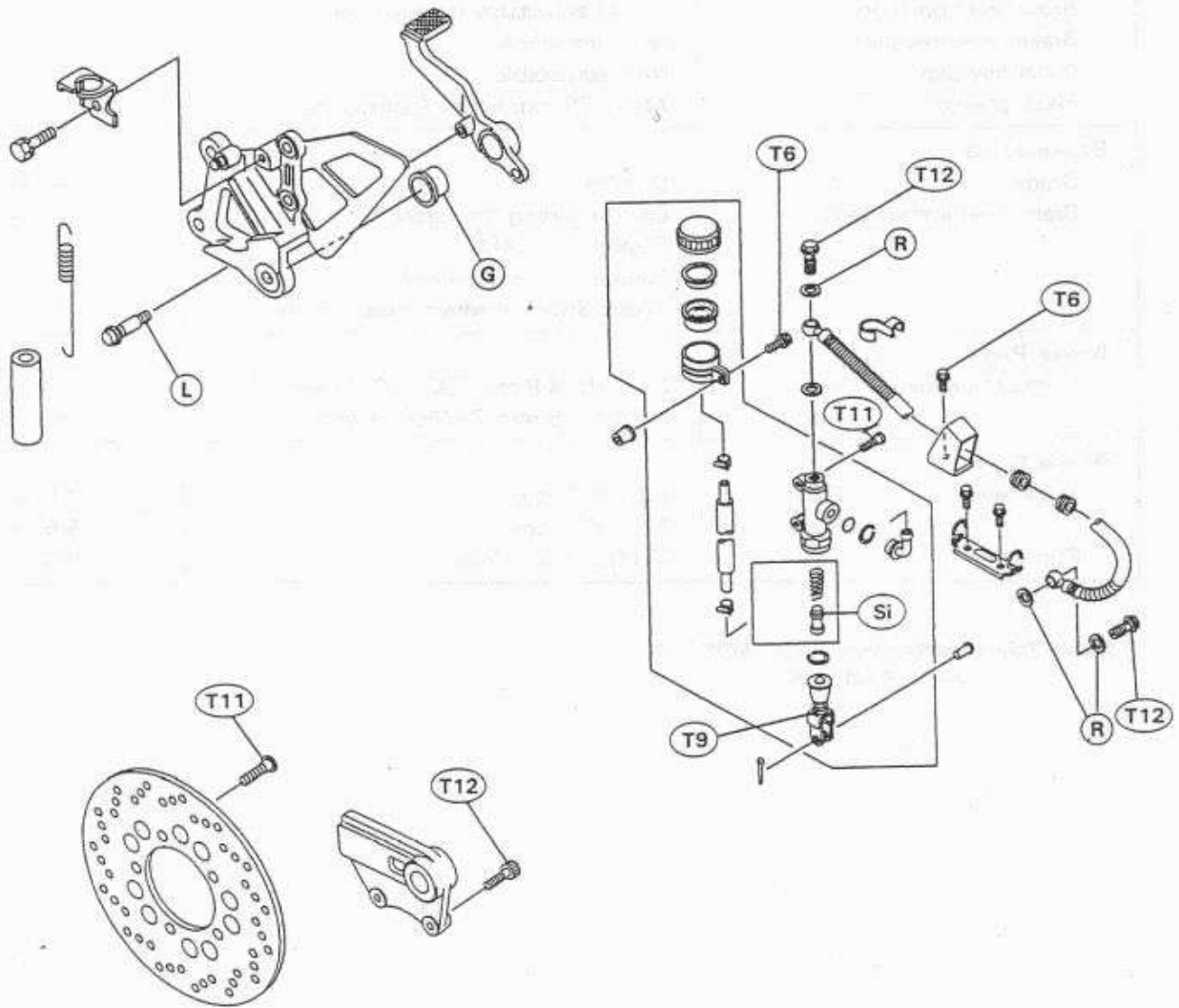

ZX750-N :

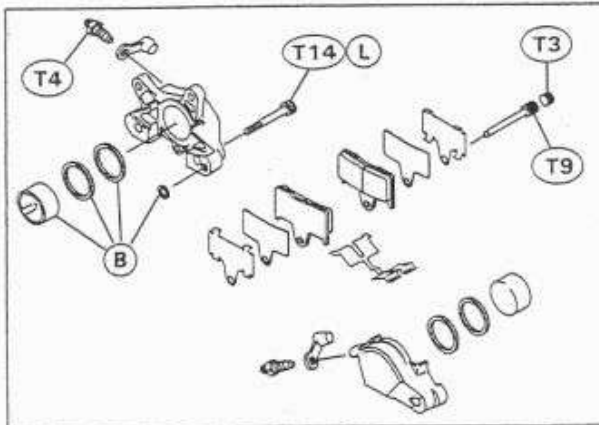

ZX750-P :

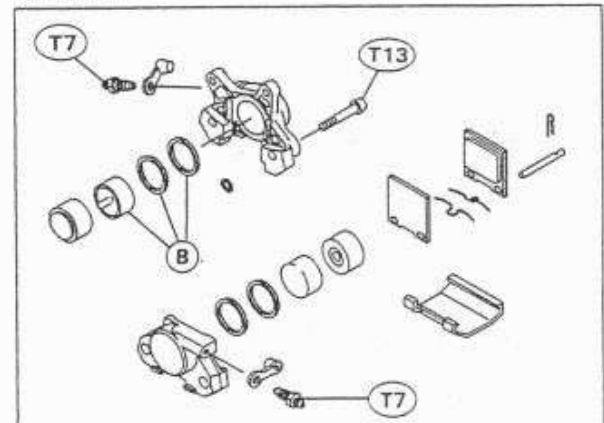

## 11-4 BRAKES

### Specifications

Item	Standard	Service Limit
<b>Brake Lever, Brake Pedal:</b> Brake lever position Brake lever free play Pedal free play Pedal position	4-way adjustable (to suit rider) Non-adjustable Non-adjustable About 70 mm below footpeg top	--- --- --- ---
<b>Brake Fluid:</b> Grade Brand (recommended)	D.O.T.4 Castrol Girling-Universal Castrol GT (LMA) Castrol Disc Brake Fluid Check Shock Premium Heavy Duty	--- --- --- --- ---
<b>Brake Pads:</b> Lining thickness: Front Rear	ZX750N: 4.8 mm, ZX750P: 4 mm ZX750N: 5 mm, ZX750P: 4 mm	1 mm 1 mm
<b>Brake Discs:</b> Thickness: Front Rear Runout	4.8 ~ 5.2 mm 5.8 ~ 6.1 mm TIR 0.2 mm or less	4.5 mm 5.5 mm TIR 0.3 mm

Special Tool – Inside Circlip Pliers: 57001-143

Jack: 57001-1238



## Brake Pedal

### Brake Pedal Position Inspection

- Check that the brake pedal [A] is in the correct position.  
[B] Footpeg

#### Pedal Position [C]

Standard: About 70 mm below top of footpeg

- ★ If it is incorrect, adjust the brake pedal position.

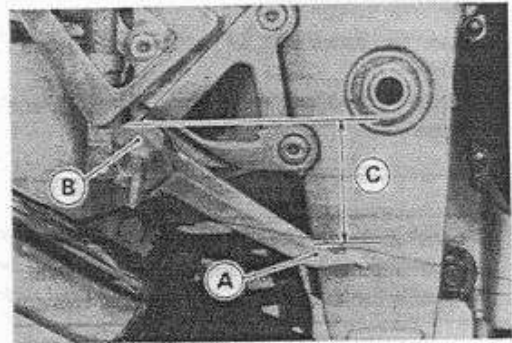

### Brake Pedal Position Adjustment

#### NOTE

○ Usually it is not necessary to adjust the pedal position, but always adjust it when the master cylinder is disassembled or pedal position is incorrect.

- Measure the length indicated in the figure.

#### Length [A]

Standard:  $67 \pm 1$  mm

- ★ If it is specified length, the brake pedal may be deformed or incorrectly installed.
- ★ If it is not within the specified length, adjust the push rod in the master cylinder as following.
  - Remove the bracket mounting bolts [B].
  - Loosen the push rod locknut [C].
  - Turn the hex head [D] of the push rod to obtain the specified length [E].
  - Tighten the locknut.

**Torque – Rear Master Cylinder Push Rod Locknut: 18 N-m (1.8 kg-m, 13.0 ft-lb)**

- Check the brake light switch operation (see Rear Brake Light Switch Adjustment in Electrical System chapter).

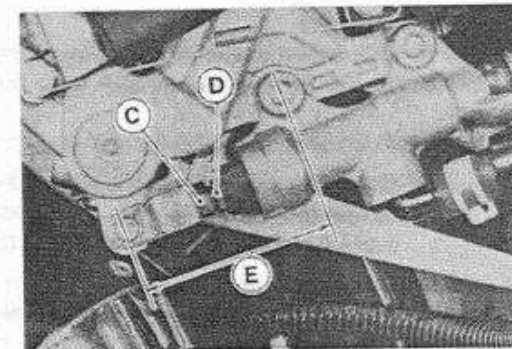
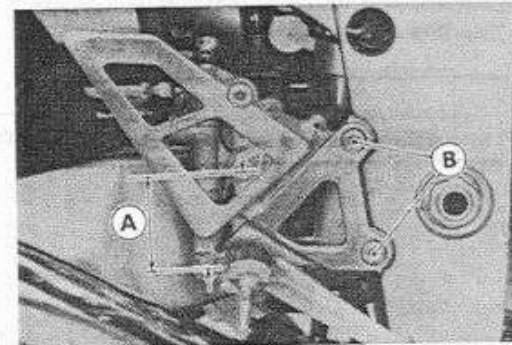

## Calipers

*Caliper Removal*

- Loosen the banjo bolt [A] at the brake hose lower end, and tighten it loosely.
- Unscrew the caliper mounting bolts [B], and detach the caliper [C] from the disc.

**CAUTION**

Do not loosen the caliper assembly bolts [D]. Take out only the caliper mounting bolts for caliper removal. Loosening the caliper assembly bolts will cause brake fluid leakage.

- Unscrew the banjo bolt and remove the brake hose [E] from the caliper (see Brake Hose Removal/Installation).

**CAUTION**

Immediately wash away any brake fluid that spills.

Front :

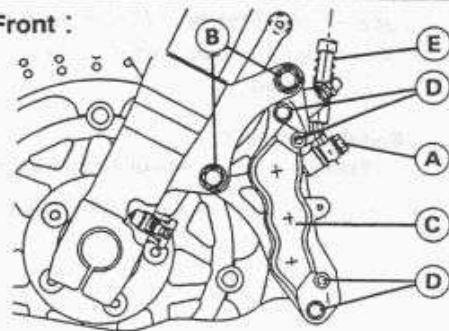

Rear :

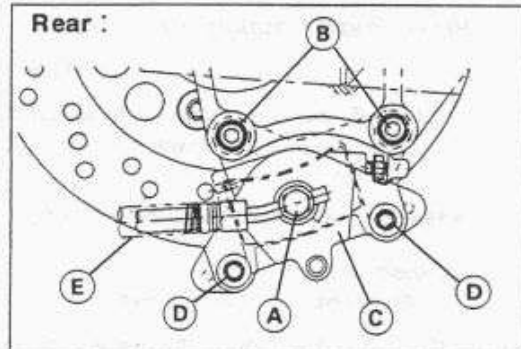
*Caliper Installation*

- Install the caliper and brake hose lower end.
- Replace the washers that are on each side of hose fitting with new ones.
- Tighten the caliper mounting bolts and banjo bolt.

**Torque – Callper Mounting Bolts (Front): 34 N-m (3.5 kg-m, 25 ft-lb)**  
**Caliper Mounting Bolts (Rear): 25 N-m (2.5 kg-m, 18.0 ft-lb)**  
**Brake Hose Banjo Bolt: 25 N-m (2.5 kg-m, 18.0 ft-lb)**

- Check the fluid level in the brake reservoirs.
- Bleed the brake line (see Bleeding the Brake Line).
- Check the brake for good braking power, not brake drag, and no fluid leakage.

**▲WARNING**

Do not attempt to drive the motorcycle until a full brake lever or pedal is obtained by pumping the brake lever or pedal until the pads are against the disc. The brakes will not function on the first application of the lever or pedal if this is not done.

*Front Caliper Disassembly*

- Loosen the banjo bolt [A] and front caliper assembly bolts [B], and tighten them loosely.
- Remove:
  - Front Caliper (see Caliper Removal)
  - Brake Pads
  - Front Caliper Assembly Bolts
  - O-rings

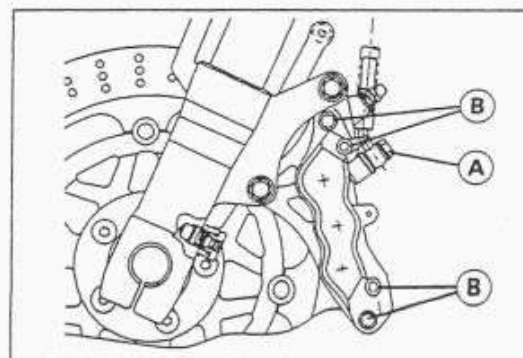

- Using compressed air, remove the pistons. One way to remove the pistons is as follows.
- Install a rubber gasket [A] and a wooden board [B] more than 10 mm thick on the caliper half, and fasten them together with a suitable bolt and nut as shown. Leave one of the oil passages [C] open.
- Lightly apply compressed air [D] to the oil passage until the pistons hit the rubber gasket. Block the hose joint opening [E] during this operation if the caliper half has the opening.
- [F] Bolt and Nut
- [G] Oil Passage sealed by Rubber Gasket.
- [H] Push down.

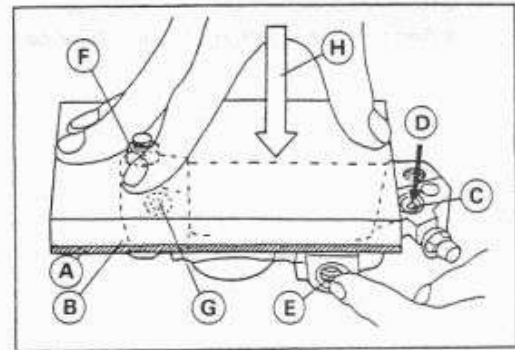

#### ⚠ WARNING

To avoid serious injury, never place your fingers or palm in front of the piston. If you apply compressed air into the caliper, the piston may crush your hand or fingers.

- Pull out the pistons by hand.
- Remove the dust seals [A] and fluid seals [B].
- Remove the bleed valve [C] and rubber cap [D].
- Repeat the previous step to remove the pistons from the other side of the caliper body.

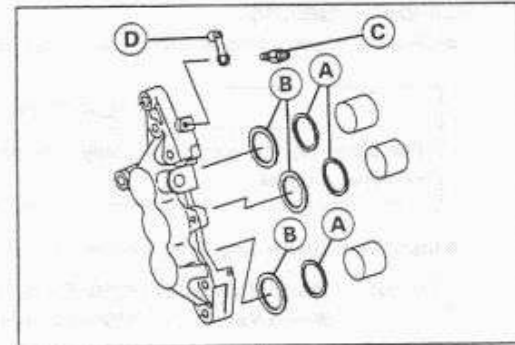

#### Rear Caliper Disassembly

- Loosen the banjo bolt [A] and rear caliper assembly bolts [B], and tighten them loosely.
- Remove:
  - Rear Caliper (see Caliper Removal)
  - Brake Pads
  - Rear Caliper Assembly Bolts
  - O-rings

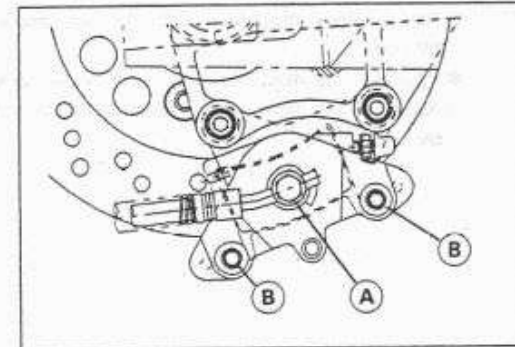

- Remove the pistons as follows:

#### Left Side Piston

- Removal of the left side piston is the same as for the front caliper (see Front Caliper Disassembly).
- [A] Left Side Caliper
- [B] Rubber Gasket
- [C] Wooden Board
- [D] Bolt and Nut
- [E] Apply compressed air.

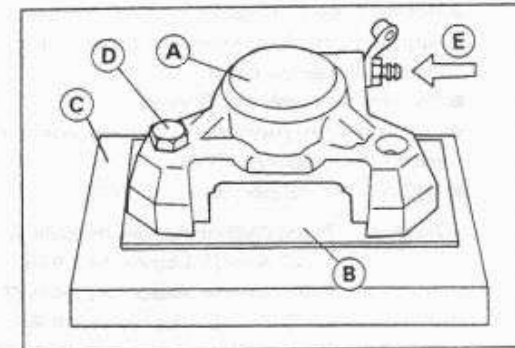

#### Right Side Piston

- Using the rear caliper assembly bolt [A], remove the piston [B] as shown.

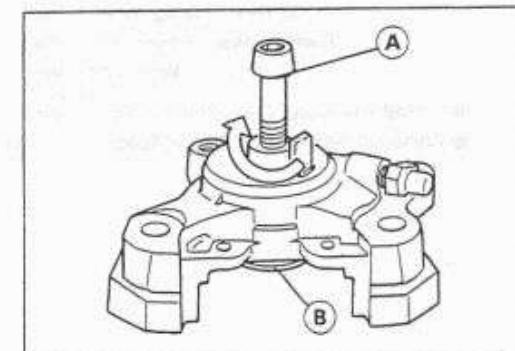

- Remove the dust seal and fluid seal.
- Remove the bleed valve and rubber cap.

### Caliper Assembly

- Clean the caliper parts except for the pads.

#### CAUTION

For cleaning the parts, use only disc brake fluid, isopropyl alcohol, or ethyl alcohol.

- Install the bleed valve and rubber cap.

**Torque – Bleed Valves (ZX750N): 5.4 N-m (0.55 kg-m, 48 in-lb)**  
**Bleed Valves (ZX750P): 7.8 N-m (0.80 kg-m, 69 in-lb)**

- Replace the fluid seals [A] with new ones.
- Apply brake fluid to the fluid seals, and install them into the cylinders by hand.
- Replace the dust seals [B] with new ones if they are damaged.
- Apply brake fluid to the dust seals, and install them into the cylinders by hand.

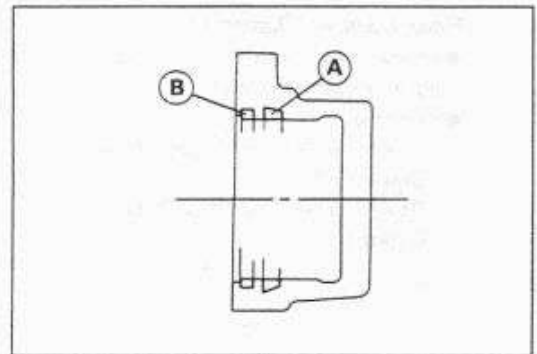

- Replace the O-rings [A] if they are damaged.
- Apply brake fluid to the outside of the pistons, and push them into each cylinder by hand.
- Be sure to install the O-rings.
- Apply a non-permanent locking agent to the threads of the caliper assembly bolts (ZX750N).
- Tighten the caliper assembly bolts.

**Torque – Front Caliper Assembly Bolts (ZX750N):**  
 23 N-m (2.3 kg-m, 16.5 ft-lb)  
**Front Caliper Assembly Bolts (ZX750P):**  
 21 N-m (2.1 kg-m, 15.0 ft-lb)  
**Rear Caliper Assembly Bolts (ZX750N):**  
 32 N-m (3.3 kg-m, 24 ft-lb)  
**Rear Caliper Assembly Bolts (ZX750P):**  
 29 N-m (3.0 kg-m, 22 ft-lb)

- Install the pads (see Brake Pad Installation).
- Wipe up any spilled brake fluid on the caliper with wet cloth.

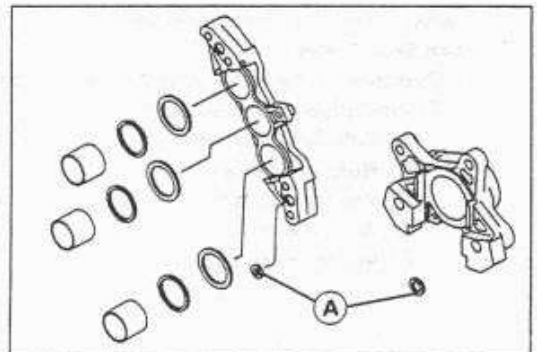

## Brake Pads

### Front Brake Pad Removal (ZX750N)

- Remove:
  - Pad Pin Plug [A]
  - Pad Pin [B]
  - Pad Spring [C]
  - Brake Pads

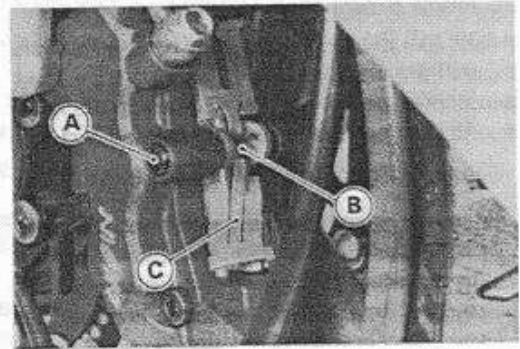

### Front Brake Pad Installation (ZX750N)

- Push the caliper pistons in by hand as far as they will go.
- Install:
  - Brake Pads
  - Pad Spring
  - Pad Pin
- Torque – Front Brake Pad Pin: 18 N-m (1.8 kg-m, 13.0 ft-lb)**
- Tighten the pad pin plug.
  - Torque – Front Brake Pad Pin Plug: 2.5 N-m (0.25 kg-m, 22 in-lb)**

#### ⚠ WARNING

Do not attempt to drive the motorcycle until a full brake lever is obtained by pumping the brake lever until the pads are against the disc. The brake will not function on the first application of the lever if this is not done.

### Front Brake Pad Removal (ZX750P)

- Remove:
  - Pad Spring Bolts [A]
  - Pad Spring [B]

- Clip [A]
- Pad Pin [B]
- Brake Pads [C]

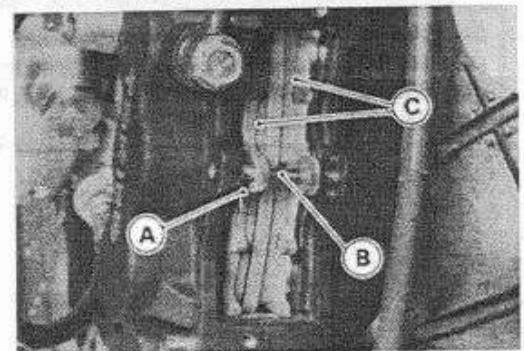
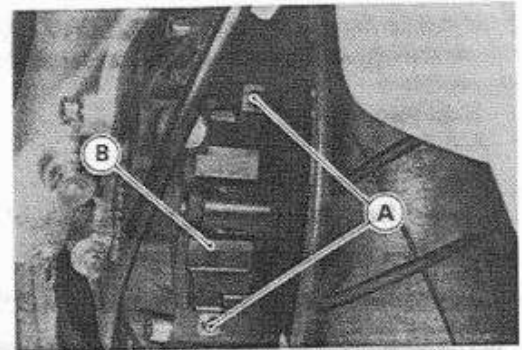

**Front Brake Pad Installation (ZX750P)**

- Push the caliper pistons in by hand as far as they will go.
- Install the brake pads.
- Install the pad pin and clip. The clip must be "outside" of the pads.
- Install the pad spring and tighten the pad spring bolts.

**Torque – Front Brake Pad Spring Bolts: 2.9 N-m (0.30 kg-m, 26 in-lb)**

**▲WARNING**

Do not attempt to drive the motorcycle until a full brake lever is obtained by pumping the brake lever until the pads are against the disc. The brake will not function on the first application of the lever if this is not done.

**Rear Brake Pad Removal (ZX750N)**

- Unscrew the caliper mounting bolts.
- Detach the caliper from the disc.
- Remove:
  - Pad Pin Plug [A]
  - Pad Pin [B]
  - Pad Spring [C]
  - Brake Pads [D]

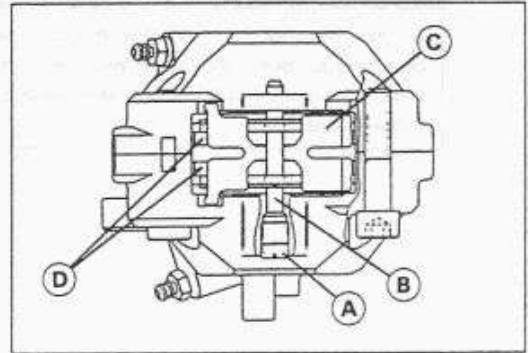
**Rear Brake Pad Installation (ZX750N)**

- Push the caliper pistons in by hand as far as they will go.
- Install:
  - Brake Pads
  - Pad Spring
  - Pad Pin

**Torque – Rear Brake Pad Pin: 18 N-m (1.8 kg-m, 13.0 ft-lb)**

- Tighten the pad pin plug.

**Torque – Rear Brake Pad Pin Plug: 2.5 N-m (0.25 kg-m, 22 in-lb)**

**▲WARNING**

Do not attempt to drive the motorcycle until a full brake pedal is obtained by pumping the brake pedal until the pads are against the disc. The brake will not function on the first application of the pedal if this is not done.

**Rear Brake Pad Removal (ZX750P)**

- Unscrew the caliper mounting bolts.
- Detach the caliper from the disc.
- Remove the piston pad cover [A].
- Draw out the clip [B], and take off the pad pin [C].
- Remove the brake pads [D] and pad springs [E].

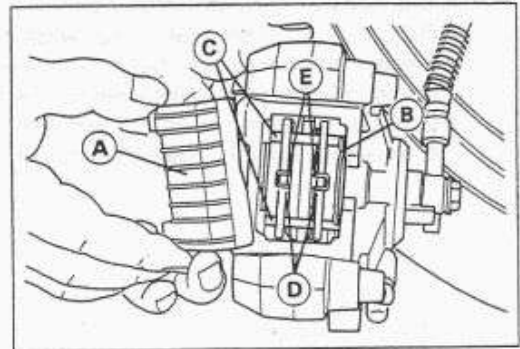
**Rear Brake Pad Installation (ZX750P)**

- Push the caliper pistons in by hand as far as they will go.
- Install the brake pads and pad springs [A] on the original position as shown.
- Install the pad pins and clip [B]. The clip must be "outside" of the pads.
- Install the piston pad cover.

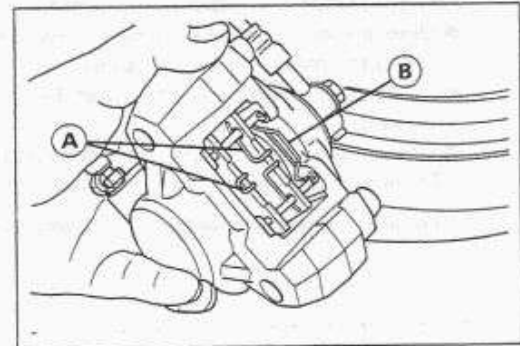
**⚠WARNING**

Do not attempt to drive the motorcycle until a full brake pedal is obtained by pumping the brake pedal until the pads are against the disc. The brake will not function on the first application of the pedal if this is not done.

**Lining Wear**

- Check the lining thickness [A] of the pads in each caliper.
- ★ If the lining thickness of either pad is less than the service limit [B], replace both pads in the caliper as a set.

**Pad Lining Thickness****ZX750N:**

Standard:	Front	4.8 mm
	Rear	5 mm

Service Limit		1 mm
---------------	--	------

**ZX750P:**

Standard:	Front	4 mm
	Rear	4 mm

Service Limit		1 mm
---------------	--	------

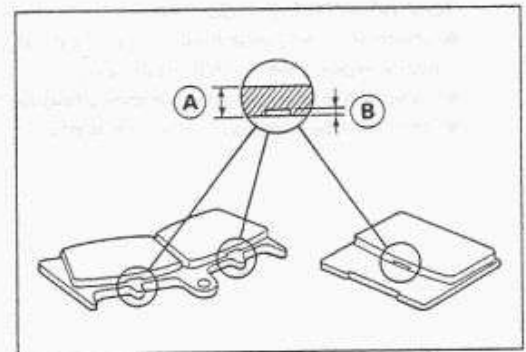

## Master Cylinder

*Front Master Cylinder Removal*

- Disconnect the front brake light switch connectors.
- Remove the banjo bolt [A] to disconnect the brake hose from the master cylinder (see Brake Hose Removal/Installation).
- Unscrew the clamp bolts [B], and take off the master cylinder [C] as an assembly with the reservoir, brake lever, and brake switch installed.

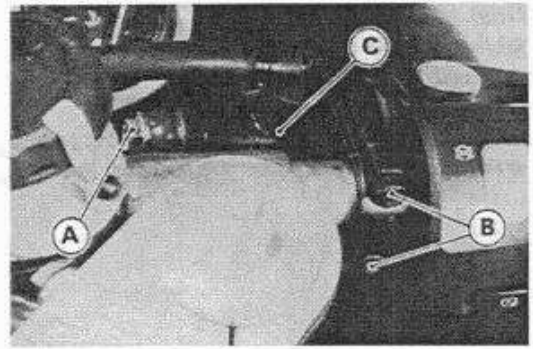
*Front Master Cylinder Installation*

- Align the punch mark [A] on the handlebar with the mating surface [B] of the master cylinder clamp.
- The master cylinder clamp must be installed with the arrow mark upward.
- Tighten the upper clamp bolt first, and then the lower clamp bolt. There will be a gap at the lower part of the clamp after tightening.

**Torque – Front Master Cylinder Clamp Bolts: 11 N-m (1.1 kg-m, 95 In-lb)**

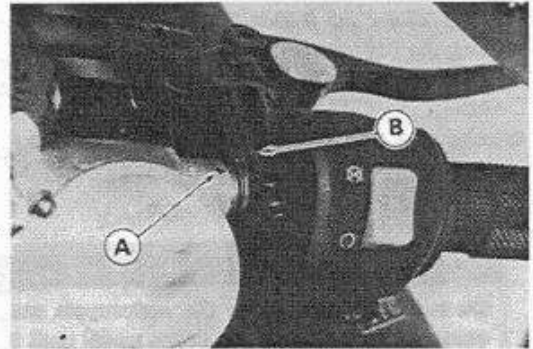

- Replace the washers that are on each side of the hose fitting with new ones.
- Tighten the brake hose banjo bolt.

**Torque – Brake Hose Banjo Bolt: 25 N-m (2.5 kg-m, 18.0 ft-lb)**

- Bleed the brake line (see Bleeding the Brake Line).
- Check the brake for good braking power, no brake drag, and no fluid leakage.

*Rear Master Cylinder Removal*

- Unscrew the brake hose banjo bolt [A] on the master cylinder (see Brake Hose Removal/Installation).
- Loosen the master cylinder mounting bolt [B] lightly.
- Remove the footpeg bracket mounting bolts [C].

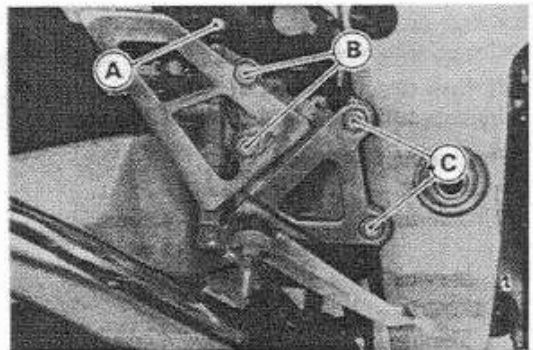

- Pull off the reservoir hose lower end [A], and drain the brake fluid into a container.
- Remove the cotter pin [B].
- Pull off the joint pin [C].

**NOTE**

○ Pull off the joint pin while pressing down the brake pedal.

- Unscrew the master cylinder mounting bolts [D], and take off the master cylinder [E].

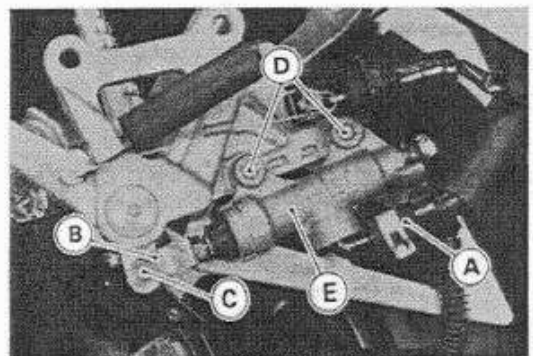



### Rear Master Cylinder Installation

- Replace the cotter pin with a new one.
- Replace the washers that are on each side of hose fitting with new ones.
- Tighten the following bolts.

**Torque – Rear Master Cylinder Mounting Bolts: 23 N-m (2.3 kg-m, 16.5 ft-lb)**

**Brake Hose Banjo Bolt: 25 N-m (2.5 kg-m, 18.0 ft-lb)**

- Bleed the brake line (see Bleeding the Brake Line).
- Check the brake for good braking power, no brake drag, and no fluid leakage.

### Front Master Cylinder Disassembly

- Remove the front master cylinder (see Front Master Cylinder Removal).
- Remove the reservoir cap and diaphragm, and pour the brake fluid into a container.
- Unscrew the locknut and pivot bolt, and remove the brake lever.
- Push the dust cover out of place, and remove the circlip.

**Special Tool – Inside Circlip Pliers: 57001-143**

- Pull out the piston [A], secondary cup [B], primary cup [C], and return spring [D].

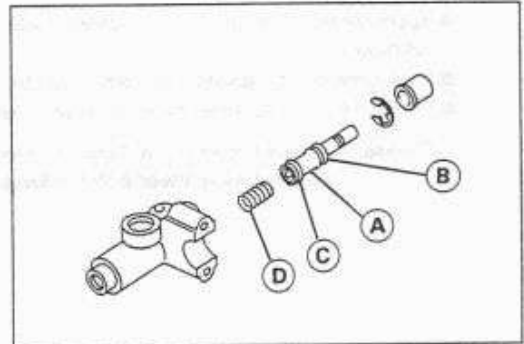

#### CAUTION

Do not remove the secondary cup from the piston since removal will damage it.

### Rear Master Cylinder Disassembly

- Remove the rear master cylinder (see Rear Master Cylinder Removal).
- Slide the dust cover on the push rod out of place, and remove the circlip.

**Special Tool – Inside Circlip Pliers: 57001-143**

- Pull out the push rod with the piston stop.
- Take off the piston [A], secondary cup [B], primary cup [C], and return spring [D].

#### CAUTION

Do not remove the secondary cup from the piston since removal will damage it.

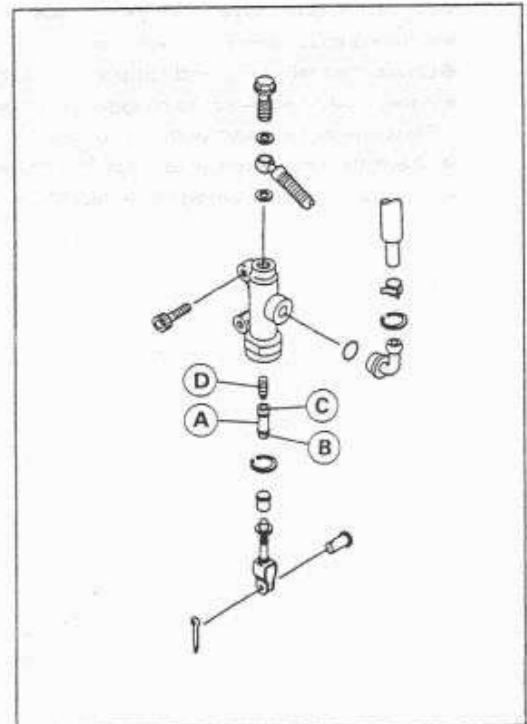

**Master Cylinder Assembly**

- Before assembly, clean all parts including the master cylinder with brake fluid or alcohol.

**CAUTION**

Except for the disc pads and disc, use only disc brake fluid, isopropyl alcohol, or ethyl alcohol for cleaning brake parts. Do not use any other fluid for cleaning these parts, Gasoline, engine oil, or any other petroleum distillate will cause deterioration of the rubber parts. Oil spilled on any part will be difficult to wash off completely, and will eventually deteriorate the rubber used in the disc brake.

- Apply brake fluid to the removed parts and to the inner wall of the cylinder.
- Take care not to scratch the piston or the inner wall of the cylinder.
- Tighten the brake lever pivot bolt and the locknut.

**Torque – Brake Lever Pivot Bolt: 1.0 N-m (0.10 kg-m, 9 in-lb)**

**Brake Lever Pivot Bolt Locknut: 5.9 N-m (0.60 kg-m, 52 in-lb)**

**Master Cylinder Inspection (Visual Inspection)**

- Disassemble the front and rear master cylinders.
  - Check that there are no scratches, rust or pitting on the inner wall of each master cylinder [A] and on the outside of each piston [B].
  - ★ If a master cylinder or piston shows any damage, replace them.
  - Inspect the primary [C] and secondary [D] cups.
  - ★ If a cup is worn, damaged softened (rotted), or swollen, the piston assembly should be replaced to renew the cups.
  - ★ If fluid leakage is noted at the brake lever, the piston assembly should be replaced to renew the cups.
- Check the dust covers [E] for damage.
  - ★ If they are damaged, replace them.
  - Check that relief [F] and supply [G] ports are not plugged.
  - ★ If the relief port becomes plugged, the brake pads will drag on the disc. Blow the ports clean with compressed air.
  - Check the piston return springs [H] for any damage.
  - ★ If the springs are damaged, replace them.

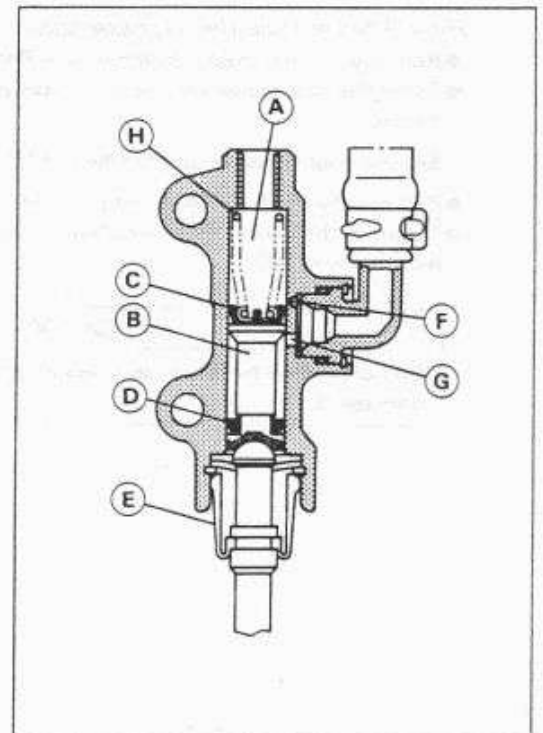
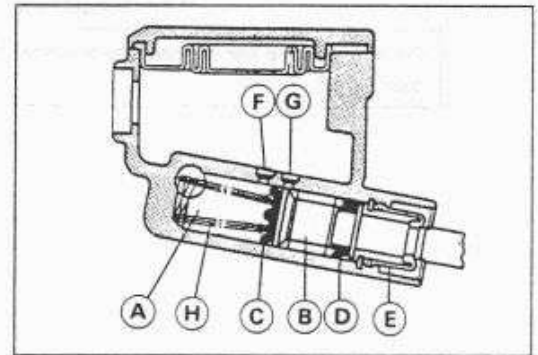

## Brake Disc

### Brake Disc Removal

- Remove the wheel (see Wheels/Tires chapter).
- Unscrew the mounting bolts, and take off the disc.

### Brake Disc Installation

- Install the disc on the wheel so that the marked side [A] faces out.
- Tighten the mounting bolts [B].

**Torque – Brake Disc Mounting bolts: 23 N-m (2.3 kg-m, 16.5 ft-lb)**

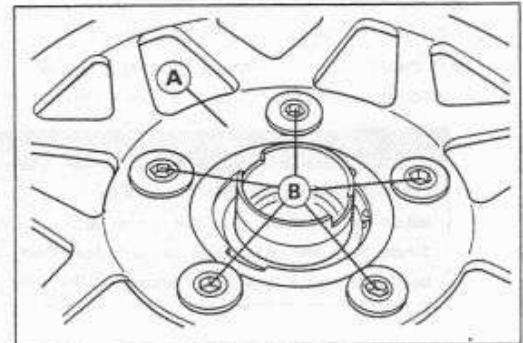

### Brake Disc Wear

- Measure the thickness of each disc [A] at the point where it has worn the most.

★ If the disc has worn past the service limit, replace it.

[B] Measuring Area

#### Front Disc Thickness

**Standard:** 4.8 ~ 5.2 mm  
**Service Limit:** 4.5 mm

#### Rear Disc Thickness

**Standard:** 5.8 ~ 6.1 mm  
**Service Limit:** 5.5 mm

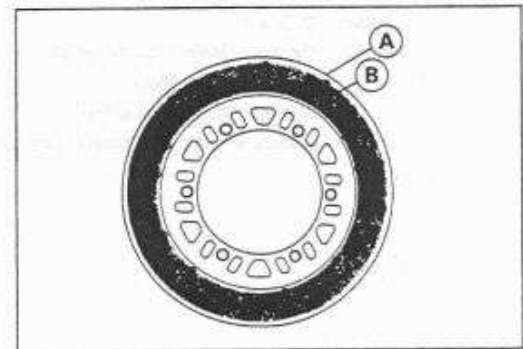

### Brake Disc Warp

- Jack up the motorcycle so that the wheel is off the ground.

**Special Tool – Jack: 57001-1238**

- For front disc inspection, turn the handlebar fully to one side.
- Set up a dial gauge against the disc [A] as shown and measure disc runout.

[B] Turn the wheel by hand.

★ If runout exceeds the service limit, replace the disc.

#### Disc Runout

**Standard:** TIR 0.2 mm or less  
**Service Limit:** TIR 0.3 mm

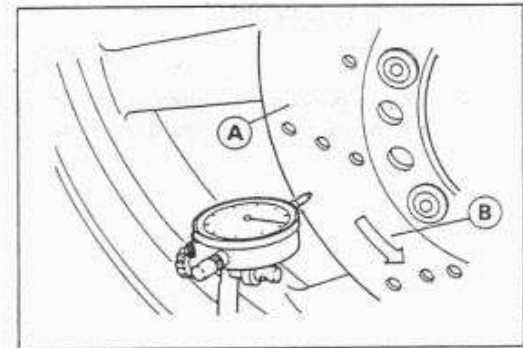

## Brake Fluid

## Level Inspection

- Check that the brake fluid level in the front brake reservoir [A] is above the lower level line [B].

## NOTE

○ Hold the reservoir horizontal by turning the handlebar when checking brake fluid level.

- ★ If the fluid level is lower than the lower level line, fill the reservoir to the upper level line [C].

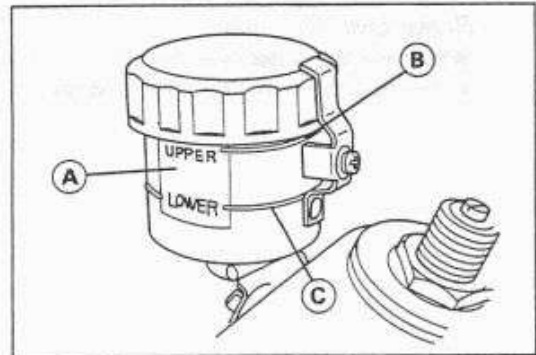

- Check that the brake fluid level in the rear brake reservoir [A] is between the upper [B] and the lower [C] level lines.

- ★ If the fluid level is lower than the lower level line, remove the side cover and fill the reservoir to the upper level line.

## ▲WARNING

Change the brake fluid in the brake line completely if the brake fluid must be refilled but the type and brand of the brake fluid that is already in the reservoir are unidentified. After changing the fluid, use only the same type and brand of fluid thereafter.

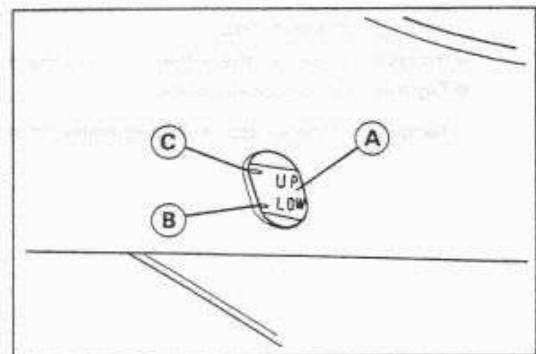

## Recommended Disc Brake Fluid

Grade: D.O.T.4

Brand: Castrol Girling-Universal

Castrol GT (LMA)

Castrol Disc Brake Fluid

Check Shock Premium Heavy Duty

## Brake Fluid Change

## NOTE

○ The procedure to change the front brake fluid is as follows.  
Changing the rear brake fluid is the same as for the front brake.

- Level the brake fluid reservoir.
- Remove the reservoir cap.
- Remove the rubber cap from the bleed valve [A] on the caliper.
- Attach a clear plastic hose [B] to the bleed valve, and run the other end of the hose into a container.
- Fill the reservoir with fresh specified brake fluid.

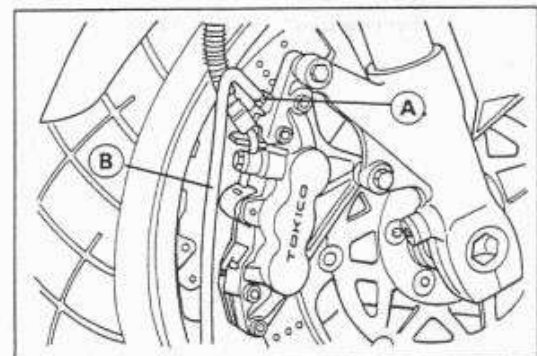

- Change the brake fluid as follows:
- Repeat this operation until fresh brake fluid comes out from the plastic hose or the color of the fluid changes.
  1. Open the bleed valve [A].
  2. Apply the brake and hold it [B].
  3. Close the bleed valve [C].
  4. Release the brake [D].

**NOTE**

- The fluid level must be checked often during the changing operation and replenished with fresh brake fluid. If the fluid in the reservoir runs out any time during the changing operation, the brakes will need to be bled since air will have entered the brake line.
- Front Brake: Repeat the above steps for the other caliper.
- Rear Brake: Repeat the above steps for the other bleed valve.

- Remove the clear plastic hose.
- Install the reservoir cap.
- Tighten the bleed valve, and install the rubber cap.

**Torque – Bleed Valves (ZX750N): 5.4 N-m (0.55 kg-m, 48 In-lb)**  
**Bleed Valves (ZX750P): 7.8 N-m (0.80 kg-m, 69 In-lb)**

- After changing the fluid, check the brake for good braking power, no brake drag, and no fluid leakage.
- ★ If necessary, bleed the air from the lines.

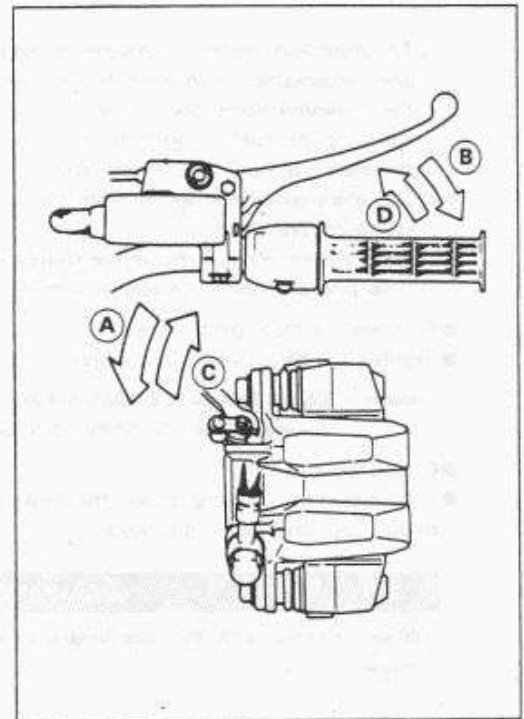
**Bleeding the Brake Line**

The brake fluid has a very low compression coefficient so that almost all the movement of the brake lever or pedal is transmitted directly to the caliper for braking action. Air, however, is easily compressed. When air enters the brake lines, brake lever or pedal movement will be partially used in compressing the air. This will make the lever or pedal feel spongy, and there will be a loss in braking power.

**⚠WARNING**

Be sure to bleed the air from the brake line whenever brake lever or pedal action feels soft or spongy after the brake fluid is changed, or whenever a brake line fitting has been loosened for any reason.

**NOTE**

- The procedure to bleed the front brake line is as follows. Bleeding the rear brake line is the same as for the front brake.

- Remove the reservoir cap, and fill the reservoir with fresh brake fluid to the upper level line in the reservoir.
- With the reservoir cap off, slowly pump the brake lever several times until no air bubbles can be seen rising up through the fluid from the holes at the bottom of the reservoir.
- Bleed the air completely from the master cylinder by this operation.
- Install the reservoir cap.
- Remove the rubber cap from the bleed valve on the caliper.
- Attach a clear plastic hose to the bleed valve, and run the other end of the hose into a container.
- Bleed the brake line and the caliper as follows:
- Repeat this operation until no more air can be seen coming out into the plastic hose.

1. Pump the brake lever until it becomes hard, and apply the brake and hold it [A].
2. Quickly open and close [B] the bleed valve while holding the brake applied.
3. Release the brake [C].

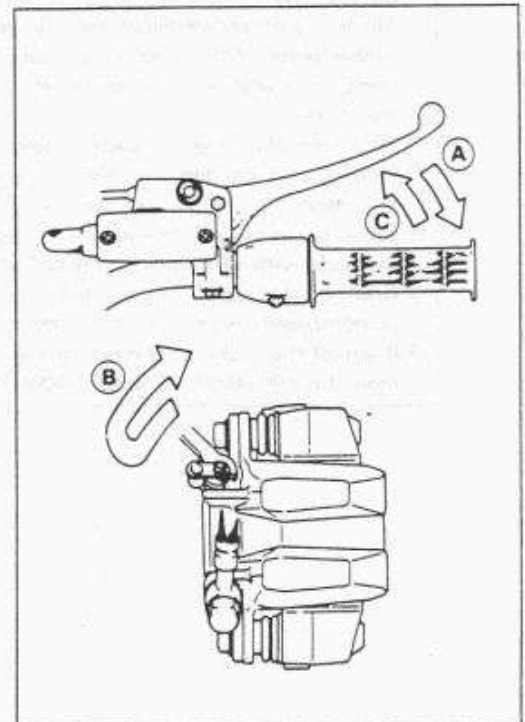

## NOTE

- *The fluid level must be checked often during the bleeding operation and replenished with fresh brake fluid as necessary. If the fluid in the reservoir runs completely out any time during bleeding, the bleeding operation must be done over again from the beginning since air will have entered the line.*
  - *Tap the brake hose lightly from the caliper to the reservoir for more complete bleeding.*
  - *Front Brake: Repeat the above steps for the other caliper.*
  - *Rear Brake: Repeat the above steps for the other bleed valve.*
  - Remove the clear plastic hose.
  - Tighten the bleed valve, and install the rubber cap.
- Torque – Bleed Valves (ZX750N): 5.4 N-m (0.55 kg-m, 48 in-lb)**  
**Bleed Valves (ZX750P): 7.8 N-m (0.80 kg-m, 69 in-lb)**
- Check the fluid level.
  - After bleeding is done, check the brake for good braking power, no brake drag, and no fluid leakage.

**▲WARNING**

**When working with the disc brake, observe the precautions listed below.**

1. Never reuse old brake fluid.
2. Do not use fluid from a container that has been left unsealed or that has been open for a long time.
3. Do not mix two types and brands of fluid for use in the brake. This lowers the brake fluid boiling point and could cause the brake to be ineffective. It may also cause the rubber brake parts to deteriorate.
4. Don't leave the reservoir cap off for any length of time to avoid moisture contamination of the fluid.
5. Don't change the fluid in the rain or when a strong wind is blowing.
6. Except for the disc pads and disc, use only disc brake fluid, isopropyl alcohol, or ethyl alcohol for cleaning brake parts. Do not use any other fluid for cleaning these parts. Gasoline, engine oil, or any other petroleum distillate will cause deterioration of the rubber parts. Oil spilled on any part will be difficult to wash off completely and will eventually deteriorate the rubber used in the disc brake.
7. When handling the disc pads or disc, be careful that no disc brake fluid or any oil gets on them. Clean off any fluid or oil that inadvertently gets on the pads or disc with a high-flash point solvent. Do not use one which will leave an oily residue. Replace the pads with new ones if they cannot be cleaned satisfactorily.
8. Brake fluid quickly ruins painted surfaces; any spilled fluid should be completely wiped up immediately.
9. If any of the brake line fittings or the bleed valve is opened at any time, the **AIR MUST BE BLED FROM THE BRAKE LINE.**

## Brake Hose

### *Brake Hose Removal/Installation*

<b>CAUTION</b>
<b>Brake fluid quickly ruins painted or plastic surfaces; any spilled fluid should be completely wiped up immediately with wet cloth.</b>

- When removing the brake hose, take care not to spill the brake fluid on the painted or plastic parts.
- When removing the brake hose, temporarily secure the end of the brake hose to some high place to keep fluid loss to a minimum.
- There are washers on each side of the brake hose fitting. Replace them with new ones when installing.
- When installing the hoses, avoid sharp bending, kinking, flattening or twisting, and route the hoses according to Hose Routing section in General Information chapter.
- Tighten the banjo bolts at the hose fittings.

**Torque – Brake Hose Banjo Bolts: 25 N-m (2.5 kg-m, 18.0 ft-lb)**

- Bleed the brake line after installing the brake hose (see Bleeding the Brake Line).

### *Brake Hose Inspection*

- The high pressure inside the brake line can cause fluid to leak or the hose to burst if the line is not properly maintained. Bend and twist the rubber hose while examining it.
- ★ Replace it if any cracks or bulges are noticed.

BRUNNEN 7-77



The main body of the page contains several paragraphs of text, likely describing the product or providing instructions. The text is oriented vertically, consistent with the rest of the page.

BRUNNEN 7-77

A section of text at the bottom of the page, possibly a footer or a concluding paragraph.



# Suspension

## Table of Contents

Exploded View .....	12-2
Specifications .....	12-5
Front Fork .....	12-6
Rebound Damping Force Adjustment .....	12-6
Compression Damping Force Adjustment .....	12-6
Spring Preload Adjustment .....	12-7
Front Fork Removal (each fork leg) .....	12-7
Front Fork Installation .....	12-8
Fork Oil Change (ZX750N) .....	12-8
Fork Oil Change (ZX750P) .....	12-11
Front Fork Disassembly (ZX750N) .....	12-13
Front Fork Assembly (ZX750N) .....	12-14
Front Fork Disassembly (ZX750P) .....	12-15
Front Fork Assembly (ZX750P) .....	12-16
Inner Tube Inspection .....	12-17
Dust Seal Inspection .....	12-17
Spring Tension .....	12-17
Rear Shock Absorber .....	12-18
Rebound Damping Force Adjustment (ZX750N) .....	12-18
Rebound Damping Force Adjustment (ZX750P) .....	12-18
Compression Damping Force Adjustment .....	12-18
Spring Preload Adjustment .....	12-19
Rear Shock Absorber Removal .....	12-19
Rear Shock Absorber Installation .....	12-20
Rear Shock Absorber Scrapping .....	12-20
Swingarm .....	12-21
Swingarm Removal .....	12-21
Swingarm Installation .....	12-22
Swingarm Bearing Removal .....	12-22
Swingarm Bearing Installation .....	12-22
Tie-Rod, Rocker Arm .....	12-23
Tie-Rod Removal .....	12-23
Tie-Rod Installation .....	12-23
Rocker Arm Removal .....	12-23
Rocker Arm Installation .....	12-23
Needle Bearing Inspection .....	12-24
Tie-Rod, Rocker Arm Sleeve Inspection .....	12-24

ZX750-N :

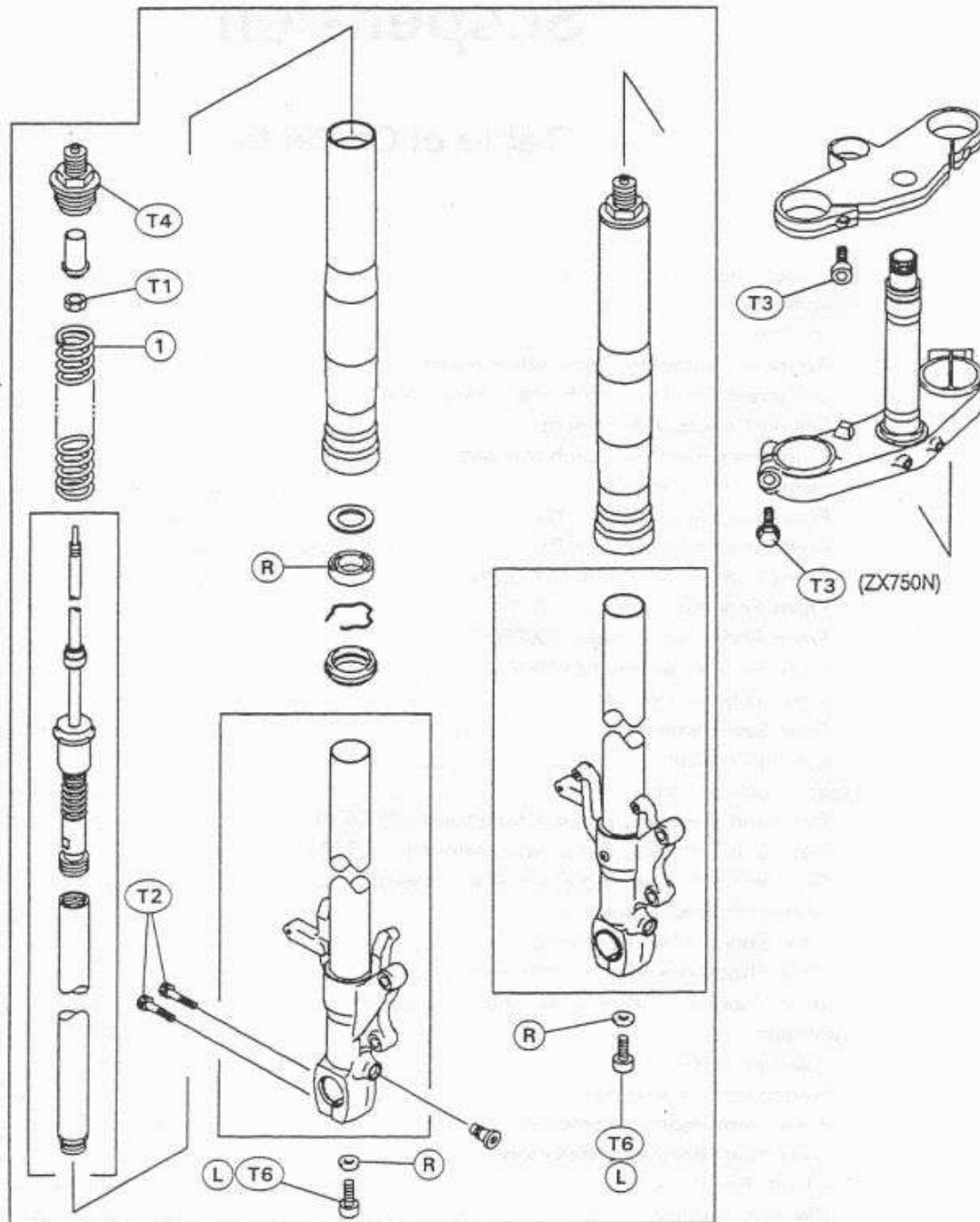

- 1. Fork Spring: Smaller end faces up.
- F: Apply fork oil.
- L: Apply a non-permanent locking agent.
- M: Apply molybdenum disulfide grease.
- R: Replacement Parts
- S: Follow the specific tightening sequence.

- T1: 15 N-m (1.5 kg-m, 11.0 ft-lb)
- T2: 20 N-m (2.0 kg-m, 14.5 ft-lb)
- T3: 21 N-m (2.1 kg-m, 15.0 ft-lb)
- T4: 23 N-m (2.3 kg-m, 16.5 ft-lb)
- T5: 28 N-m (2.9 kg-m, 21 ft-lb)
- T6: 39 N-m (4.0 kg-m, 29 ft-lb)

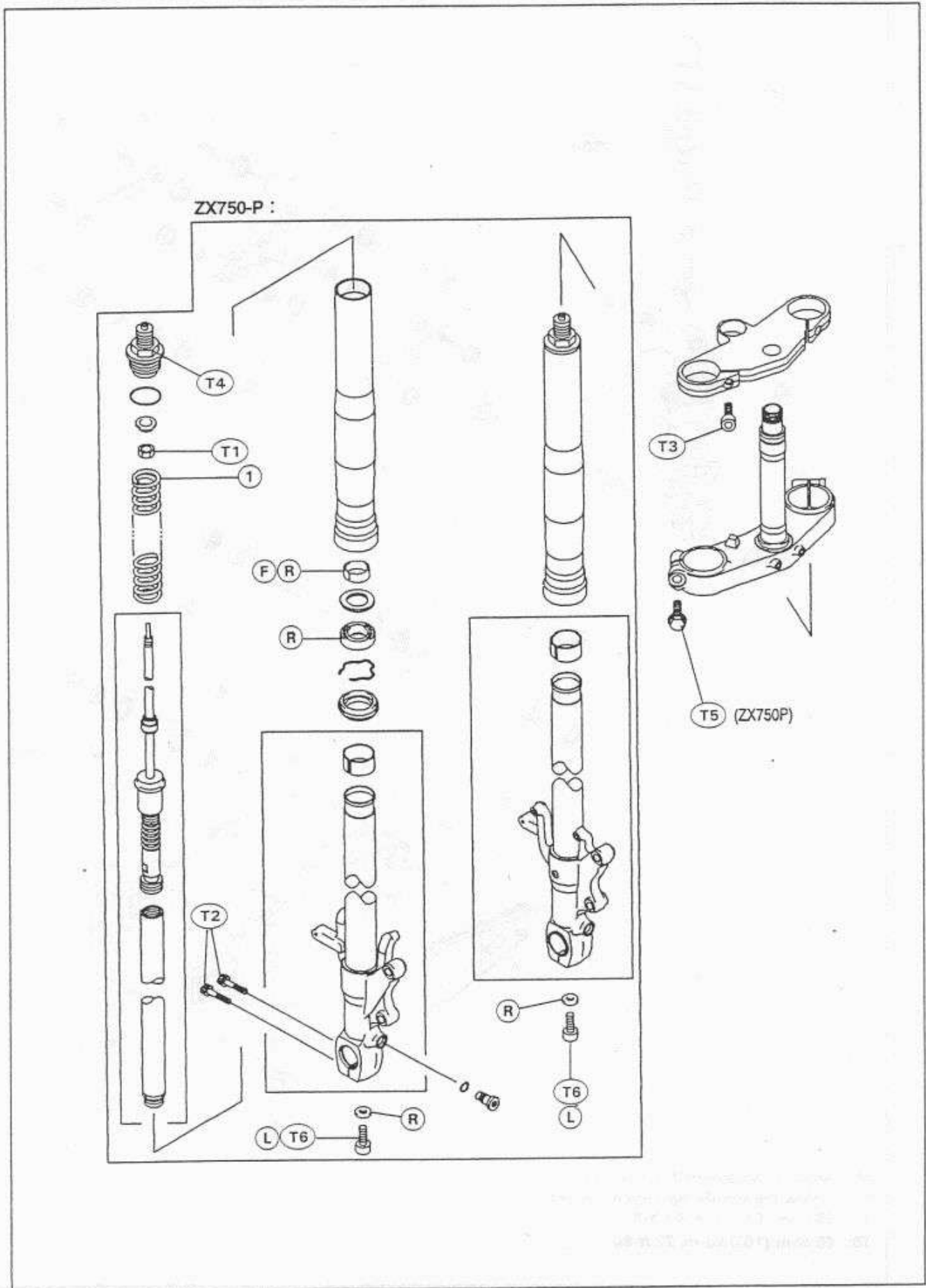

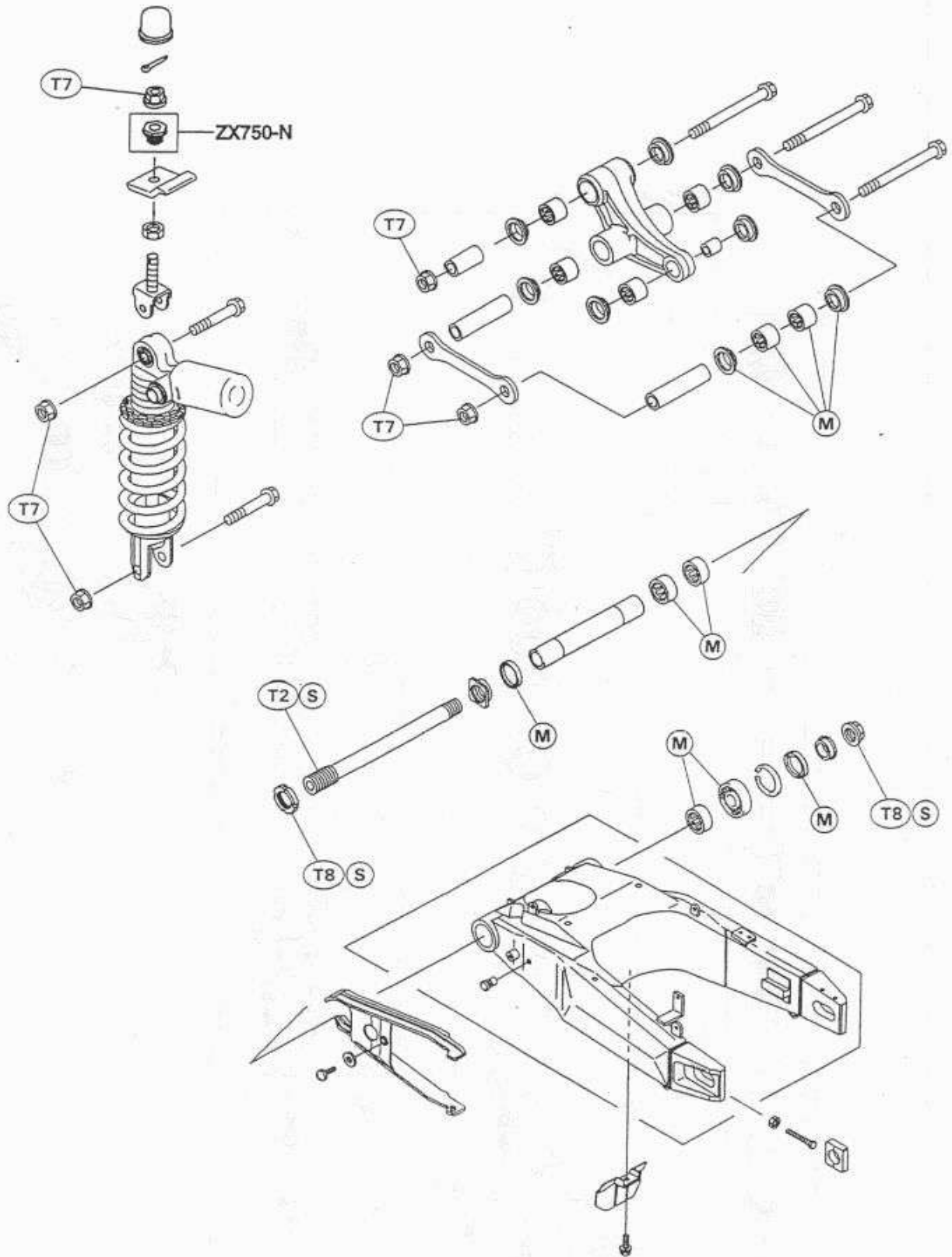

- M: Apply molybdenum disulfide grease.
- S: Follow the specific tightening sequence.
- T7: 59 N-m (6.0 kg-m, 43 ft-lb)
- T8: 98 N-m (10.0 kg-m, 72 ft-lb)

## Specifications

Item	Standard	Service Limit
<b>Front Fork (per one unit):</b>		
Fork inner tube diameter:	φ43 mm	---
Rebound damper (upper) setting:		
ZX750N	7th click from the first click of the fully clockwise position	---
ZX750P	7th click from the first click of the fully clockwise position	---
Compression damper (lower) setting:		
ZX750N	12th click from the first click of the fully clockwise position	---
ZX750P	6th click from the first click of the fully clockwise position	---
Fork spring preload setting:		
ZX750N	Adjuster protrusion is 11 mm (4 Marks)	4 ~ 19 mm
ZX750P	Adjuster protrusion is 16mm (6.5 Marks)	5 ~ 20 mm
Fork oil viscosity:	KAYABA 01 (SAE5W)	---
Fork oil capacity:		
ZX750N	495 ± 4 mL (completely dry) approx. 420 mL (when changing oil)	---
ZX750P	431 ± 4 mL (completely dry) approx. 365 mL (when changing oil)	---
Fork oil level: (fully compressed, without main spring, below from tube top)		
ZX750N	88 ± 2 mm	---
ZX750P	110 ± 2 mm	---
Fork spring free length:		
ZX750N	298.1 mm	292 mm
ZX750P	328.9 mm	322 mm
<b>Rear Shock Absorber:</b>		
Rebound damping setting:		
ZX750N	8th click from the first click of the fully clockwise position	---
ZX750P	No.2	1 ~ 4
Compression damping setting:		
ZX750N	17th click from the first click of the fully clockwise position	---
ZX750P	15th click from the first click of the fully clockwise position	---
Spring preload setting:		
ZX750N	Spring free length minus 13 mm	0 ~ 28 mm
ZX750P	Spring free length minus 13 mm	0 ~ 20.5 mm
Gas pressure	980 kPa (10 kg/cm <sup>2</sup> , 142 psi, Non-adjustable)	---

**Special Tool – Inside Circlip Pliers:** 57001-143  
**Oil Seal & Bearing Remover:** 57001-1058  
**Steering Stem Nut Wrenches:** 57001-1100 (2)  
**Bearing Driver Set:** 57001-1129  
**Fork Outer Tube Weight:** 57001-1218  
**Jack:** 57001-1238  
**Fork Oil Level Gauge:** 57001-1290  
**Fork Cylinder Holder:** 57001-1297 (ZX750P)  
**Fork Piston Rod Puller, M10 x 1.0:** 57001-1298  
**Fork Spring compressor:** 57001-1338 (ZX750P)  
**Fork Oil Seal Driver, φ43:** 57001-1340  
**Socket Wrench:** 57001-1370  
**Fork Cylinder Holder:** 57001-1396 (ZX750N)

## Front Fork

### Rebound Damping Force Adjustment

- To adjust the rebound damping force, turn the rebound damping adjuster [A] until you feel a click.
- The standard adjuster setting for the average-build rider of 68 kg (150 lb) with no passenger and no accessories is the **7th click** from the 1st click of the fully clockwise position.

**⚠ WARNING**

**If both adjusters are not adjusted equally, handling may be impaired and a hazardous condition may result.**

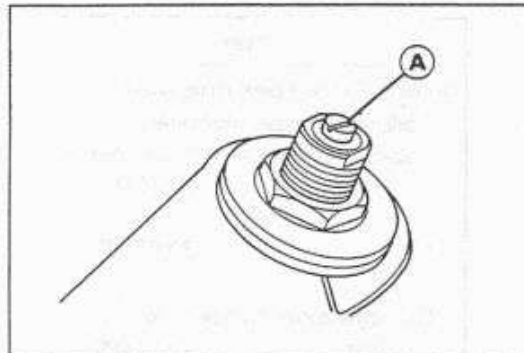

- The damping force can be left soft for average riding. But it should be adjusted harder for high speed riding or riding with a passenger. If the damping feels too soft or too stiff, adjust it in accordance with the following table.

### Rebound Damping Force Adjustment

Adjuster Position	Damping Force	Setting	Load	Road	Speed
12 ~ 13	Weak	Soft	Light	Good	Low
↑	↑	↑	↑	↑	↑
↓	↓	↓	↓	↓	↓
1	Strong	Hard	Heavy	Bad	High

### Compression Damping Force Adjustment

- To adjust the compression damping force, turn the compression damping adjuster [A] until you feel a click.
- The standard adjuster setting for the average-build rider of 68 kg (150 lb) with no passenger and no accessories is the **12th click (ZX750N), 6th click (ZX750P)** from the 1st click of the fully clockwise position.

**⚠ WARNING**

**If both adjusters are not adjusted equally, handling may be impaired and a hazardous condition may result.**

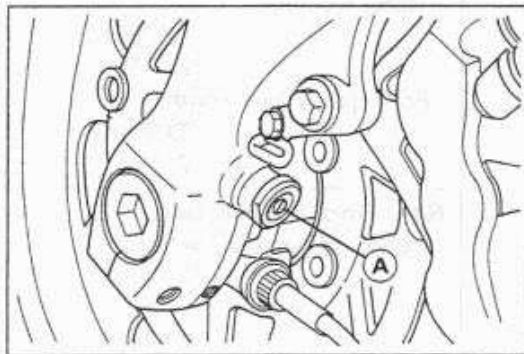

- The damping force can be left soft for average riding. But it should be adjusted harder for high speed riding or riding with a passenger. If the damping feels too soft or too stiff, adjust it in accordance with the following table.

### Compression Damping Force Adjustment

Adjuster Position	Damping Force	Setting	Load	Road	Speed
28 (N) 8 (P)	Weak	Soft	Light	Good	Low
↑	↑	↑	↑	↑	↑
↓	↓	↓	↓	↓	↓
1	Strong	Hard	Heavy	Bad	High

(N): ZX750N

(P): ZX750P

**Spring Preload Adjustment**

- Turn the spring preload adjuster [A] to change spring preload setting.
- The standard adjuster setting for the average-build rider of 68 kg (150 lb) with no passenger and no accessories is the 4th mark (11mm, ZX750N), 6.5th mark (16 mm, ZX750P) from top as shown.

**Adjuster Protrusion (from top)**

- Standard: 4th Mark (11 mm, ZX750N)  
6.5 th Mark (16mm, ZX750P)
- Usable Range 1 ~ 8th Mark (5 ~ 20 mm)

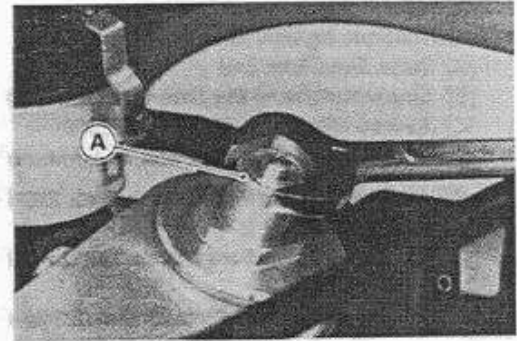

**⚠WARNING**

If both adjusters are not adjusted equally, handling may be impaired and a hazardous condition may result.

- The spring preload can be left soft for average riding. But it should be adjusted harder for high speed riding or riding with a passenger. If the spring action feels too soft or too stiff, adjust it in accordance with the following table.

**Spring Action**

Adjuster Position	Dumping Force	Setting	Load	Road	Speed
8(20mm)	Weak	Soft	Light	Good	Low
↑	↑	↑	↑	↑	↑
↓	↓	↓	↓	↓	↓
1(5mm)	Strong	Hard	Heavy	Bad	High

**Front Fork Removal (each fork leg)**

- Remove:
  - Upper and Lower Fairings (see Frame chapter)
  - Front Wheel (see Wheels/Tires chapter)
  - Front Fender (see Frame chapter)
- ★ Loosen the upper fork clamp bolt [A], handlebar holder bolt [B] and fork top plug [C] beforehand if the fork leg is to be disassembled.

**NOTE**

○ Loosen the top plug after loosening the upper fork clamp bolt and handlebar holder bolt.

- Loosen the upper fork clamp bolt [A], handlebar holder bolt [B] and lower fork clamp bolt [C].
- With a twisting motion, work the fork leg down and out.

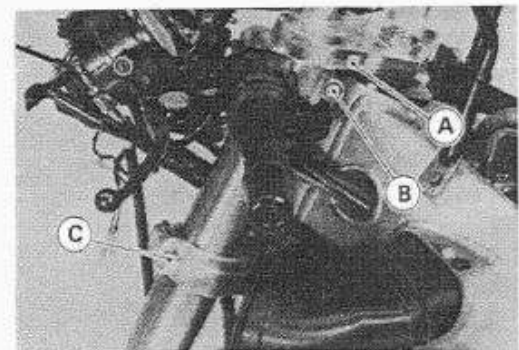
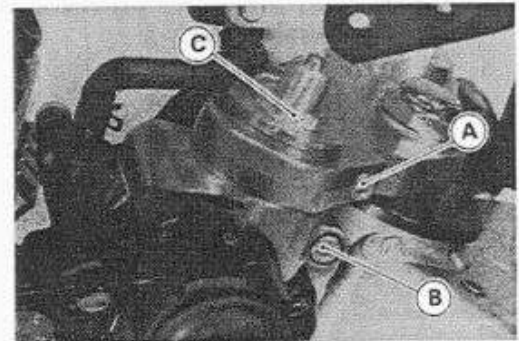

## Front Fork Installation

- Install the fork leg as shown.
  - [A] Outer Tube Top End
  - [B] Upper Surface of the Steering Stem Head
  - [C] 17 mm (ZX750N), 2 mm (ZX750P)
- Tighten the lower fork clamp bolt and fork top bolt.

**Torque – Lower Front Fork Clamp Bolt (ZX750N): 21 N-m (2.1 kg-m, 15.0 ft-lb)**

**Lower Front Fork Clamp Bolt (ZX750P): 28 N-m (2.9 kg-m, 21 ft-lb)**

**Front Fork Top Plug: 23 N-m (2.3 kg-m, 16.5 ft-lb)**

- Tighten the handlebar holder bolt and upper fork clamp bolt.

**Torque – Handlebar Holder Bolt: 23 N-m (2.3 kg-m, 16.5 ft-lb)**

**Upper Front Fork Clamp Bolt: 21 N-m (2.1 kg-m, 15.0 ft-lb)**

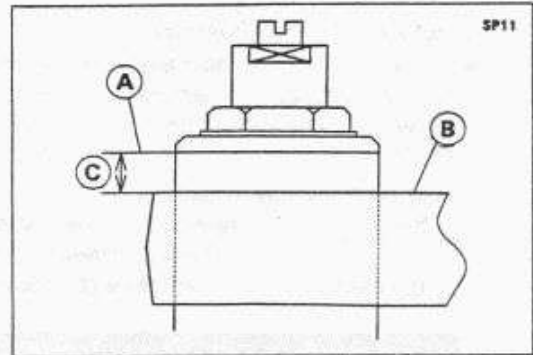

### NOTE

○ Tighten the top plug before tightening the handlebar holder bolt and upper fork clamp bolt.

- Install the removed parts (see appropriate chapters).
- Adjust the spring preload and the damping force.

## Fork Oil Change (ZX750N)

- Remove the front fork (see Front Fork Removal).
- Hold the inner tube lower end in a vise.
- Turn the spring preload adjuster [A] counterclockwise until the fully position.
- Remove the top plug [B] from the outer tube.

- Holding the piston rod nut [A] with a suitable wrench [B] remove the top plug from the piston rod.

- Remove:
  - Spacer [A]
  - Fork Spring [B]

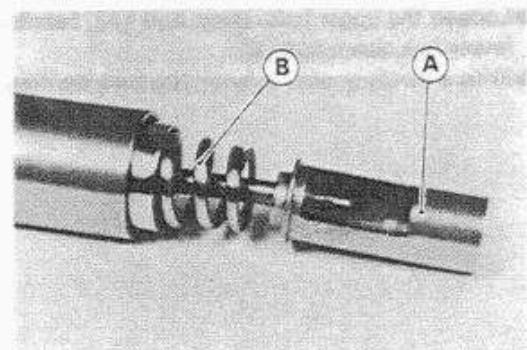
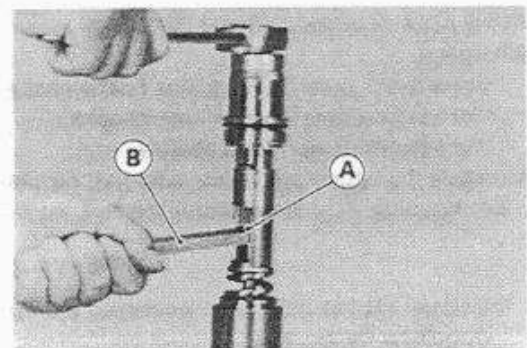
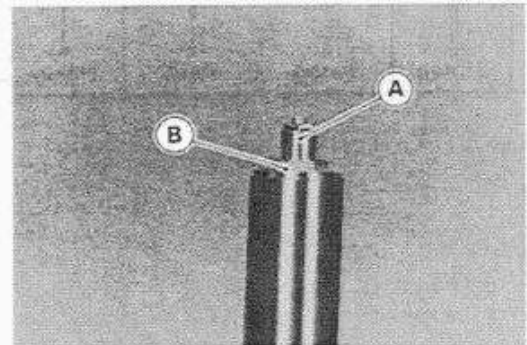



- Remove the rebound damping adjuster rod [A] from the piston rod [B].
- Drain the fork oil into a suitable container.
- Pump the piston rod up and down at least ten times to expel the oil from the fork.

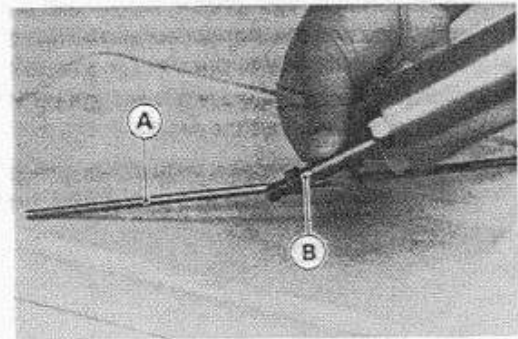

- Hold the fork tube upright, press the outer tube and the piston rod all the way down.

**NOTE**

- *The spring should not be installed.*
- Fill the front fork with the specified oil.

**Recommended Oil:**  
**KAYABA 01 (SAE5W)**

**Fork Oil Capacity (when changing oil):**  
**Approx. 420 mL**

- Purge the air from the fork cylinder by gently moving the rod puller [A] up and down ten times.

**Special Tool – Fork Piston Rod Puller, M10 x 1.0: 57001-1298**

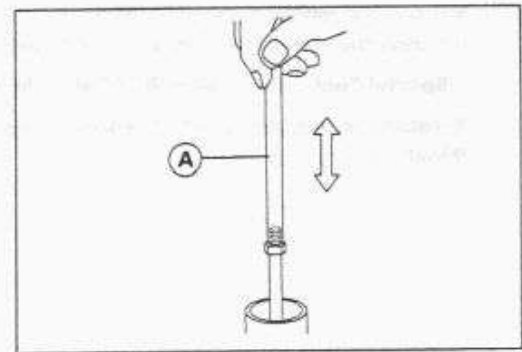

- Purge the air from between the inner and outer tubes by pumping the outer tube up and down.
- After purging the air from the assembly, let it sit for about five minutes so that any suspended air bubbles can surface.

- Set the oil level gauge stopper [A] so that its lower side shows the oil level distance specified.

**Special Tool – Fork Oil Level Gauge: 57001-1290 [B]**

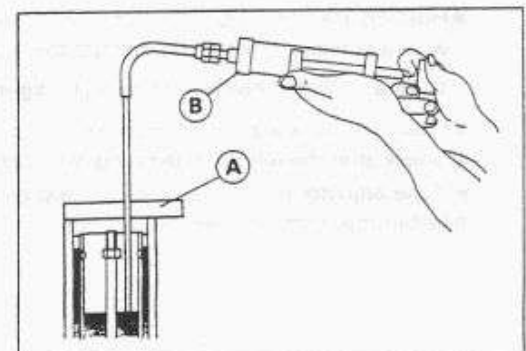

- With the fork fully compressed, insert the gauge tube into the inner tube and position the stopper across the top of the inner tube.
- Pull the handle slowly to draw out all excess oil.
- ★ If no oil is drawn out, there is not enough oil in the fork. Pour in some more oil, then draw out the excess.

**Oil Level (fully compressed, without fork spring)**

**Standard:**  $88 \pm 2$  mm (below from inner tube top)

- Pull the piston rod [A] up above the inner tube top.
- Holding the piston rod with a plier tighten the rod nut [B] lightly so that the chamfered side is down.
- [C] Cloth

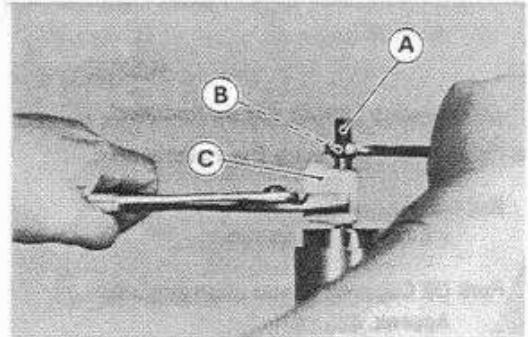

**CAUTION**

Be careful not to damage the piston rod.

- Insert the rebound damping adjuster rod into the piston rod.
- Screw the fork piston rod puller onto the end of the rod.

**Special Tool – Fork Piston Rod Puller, M10 x 1.0: 57001-1298**

- Install the fork spring with the smaller end facing upward.
- Install the spacer.

- Check the O-ring [A] on the top plug and replace it with a new one if damaged.
- Screw in the damper adjuster [B] of the top plug so that the distance between the adjuster bottom and the plug body [C] end is 13 mm [D].

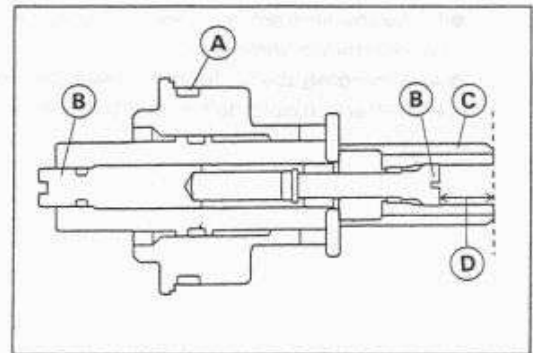

- Holding the top plug [A] with a wrench, tighten the piston rod nut with a suitable wrench [B] against the top plug.

**Torque – Piston Rod Nut: 15 N-m (1.5 kg-m, 11.0 ft-lb)**

- Raise the outer tube and screw the top plug into it.
- Check that the rebound damping adjuster do not turn clockwise.
- ★ If the adjuster turn, install the top plug over again.
- Install the front fork (see Front Fork Installation).

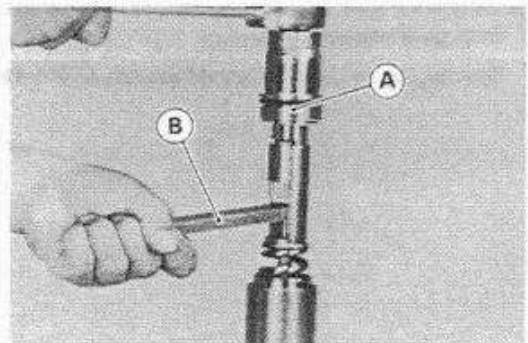

**Fork Oil Change (ZX750P)**

- Remove the front fork (see Front Fork Removal).
- Hold the inner tube lower end in a vise.
- Unscrew the top plug [A] out of the outer tube.
- While holding up the top plug by one person, push down the fork spring compressor [B] and insert it between the piston rod nut [C] and the spring seat [D].

**Special Tool – Fork Spring Compressor: 57001-1338**

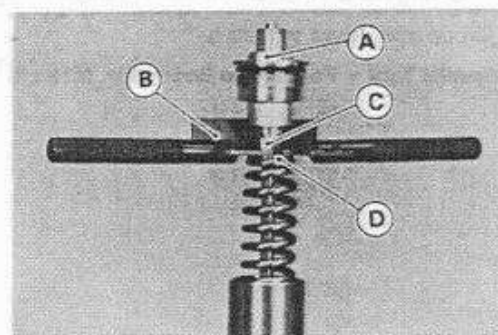

- Holding the piston rod nut with a wrench [A], remove the top plug [B] from the piston rod.

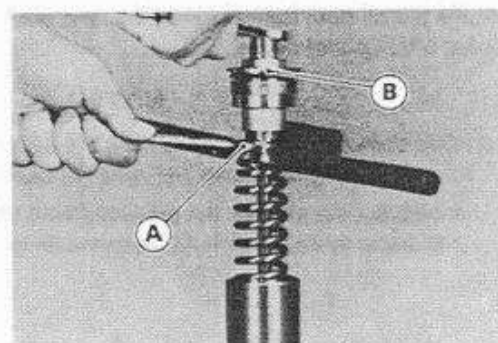

- Remove:
  - Rebound Damping Adjuster Rod [A]
  - Fork Spring Compressor [B]

**NOTE**

- While holding down the spring seat [C], pull out the fork spring compressor.

- Remove:
  - Spring Seat
  - Fork Spring [D]

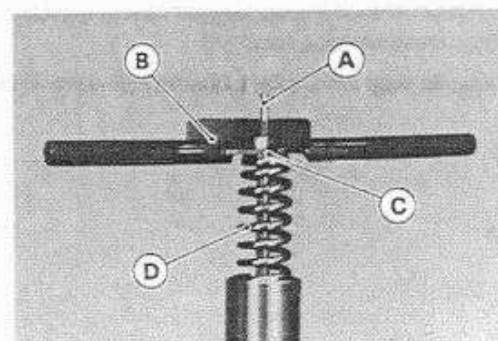

- Drain the fork oil into a suitable container.
- Pump the piston rod [A] up and down at least ten times to expel the oil from the fork.

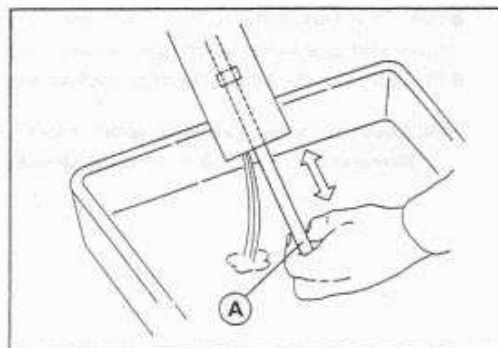

- Hold the fork tube upright, press the outer tube and the piston rod all the way down.

**NOTE**

- The spring should not be installed.

- Fill the front fork to the top with the specified oil.

**Recommended Oil**

**KAYABA 01 (SAE5W)**

- Purge the air from the fork cylinder by gently moving the rod puller [A] up and down ten times.

**Special Tool – Fork Piston Rod Puller, M10 x 1.0: 57001-1298**

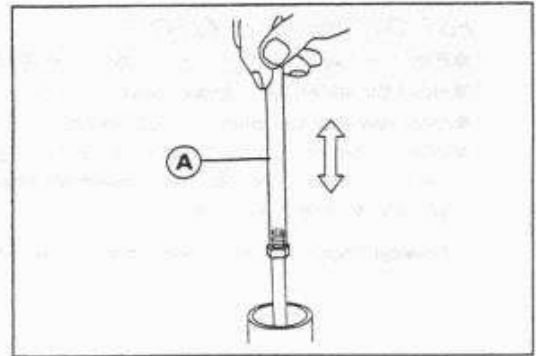

- Purge the air from between the inner and outer tubes by pumping the outer tube up and down.

### NOTE

○ While doing this, take care to keep the oil level topped off so that it stays above the two holes [A] near the top of the inner tube [B].

- After purging the air from the assembly, let it sit for about five minutes so that any suspended air bubbles can surface.

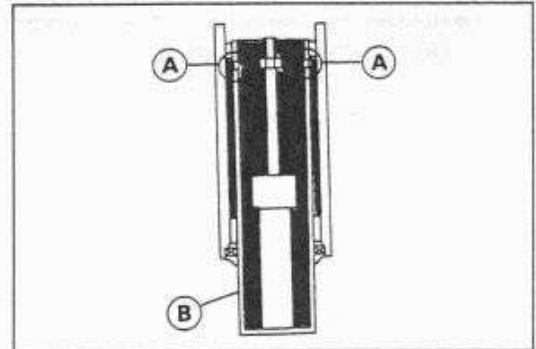

- Set the oil level gauge stopper [A] so that its lower side shows the oil level distance specified.

**Special Tool – Fork Oil Level Gauge: 57001-1290 [B]**

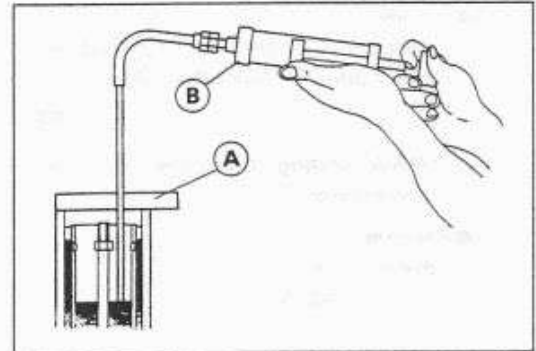

- With the fork fully compressed, insert the gauge tube into the inner tube and position the stopper across the top of the outer tube.
- Pull the handle slowly to draw out all excess oil.

**Oil Level (fully compressed, without fork spring)**

**Standard: 110 ± 2 mm (below from outer tube top)**

- Pull the piston rod [A] up above the outer tube top.
- Screw the rod nut [B] on to the piston rod with the chamfered side [C] down.
- Check that the visible thread length is at least 12 mm [D].

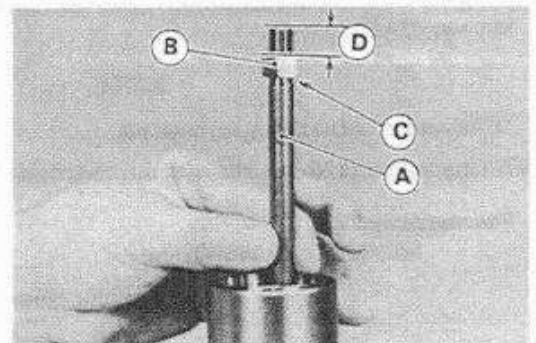

- Insert the rebound damping adjuster rod into the piston rod.
- Screw the fork piston rod puller onto the end of the rod.

**Special Tool – Fork Piston Rod Puller, M10 x 1.0: 57001-1298**

- Install the fork spring with the smaller end facing upward.
- Install the spring seat.

- While holding up the fork piston rod puller [A] by one person, push down the fork spring compressor [B] and insert it between the piston rod nut [C] and spring seat [D].

**Special Tool – Fork Spring Compressor: 57001-1338**

- Remove the fork piston rod puller.

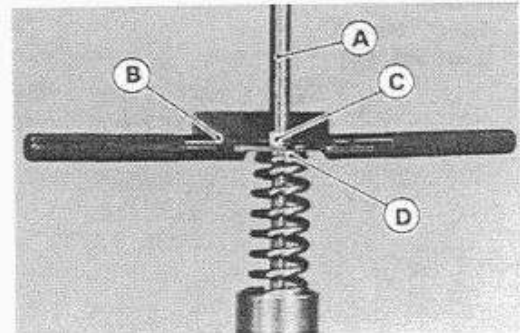

- Check the O-ring [A] on the top plug and replace it with a new one if damaged.
- Screw in the damper adjuster [B] of the top plug so that the distance between the adjuster bottom and the spring adjuster [C] end is 25 mm [D].

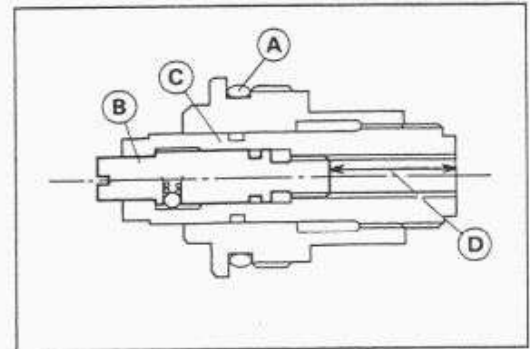

- Holding the top plug [A] with a wrench, tighten the piston rod nut [B] against the top plug.

**Torque – Piston Rod Nut: 15 N-m (1.5 kg-m, 11.0 ft-lb)**

- Remove the fork spring compressor.
- Raise the outer tube and screw the top plug into it.
- Install the front fork (see Front Fork Installation).

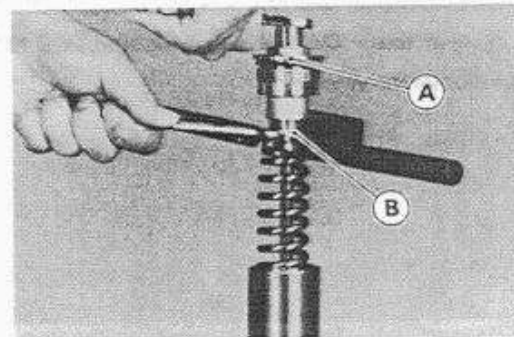

### Front Fork Disassembly (ZX750N)

- Remove the front fork (see Front Fork Removal).
- Drain the fork oil (see Fork Oil Change).
- Hold the front fork in a vise [A].
- Stop the cylinder [B] from turning by using the fork cylinder holder [C].

**Special Tool – Fork Cylinder Holder: 57001-1396**

- Unscrew the Allen bolt [D], then remove the bolt and gasket out of the bottom of the inner tube.

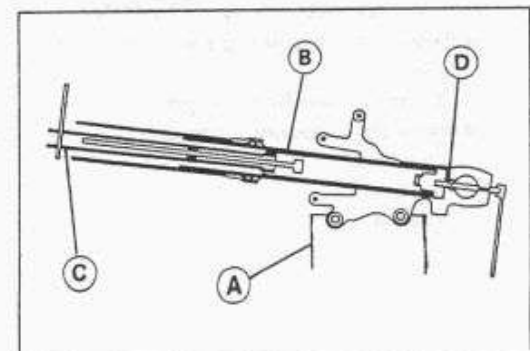

- Take the piston cylinder unit [A].
- Do not disassemble the piston cylinder unit.

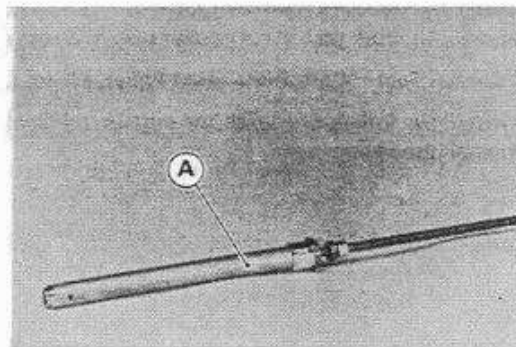

- Remove:
  - Outer Tube [A]
  - Dust Seal [B]

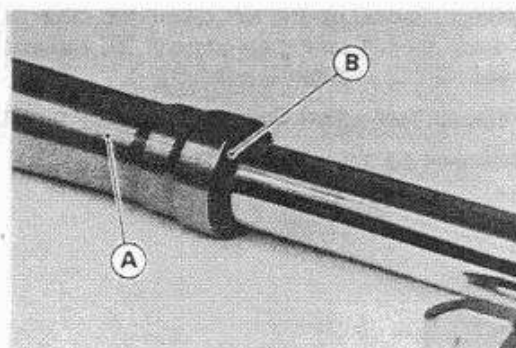

Retaining Ring [A]

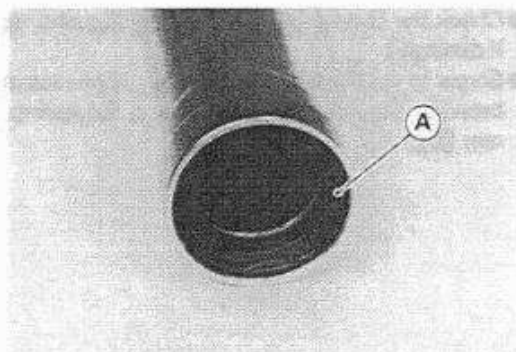

- Remove the oil seal [A] using the oil seal & bearing remover [B].

Special Tool – Oil Seal & Bearing Remover: 57001-1058

- Remove the washer.

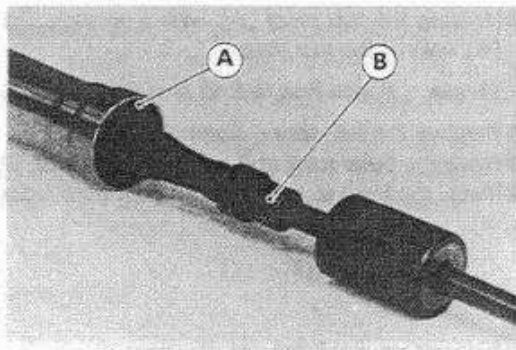

### Front Fork Assembly (ZX750N)

- Replace the following parts with new ones.
  - Oil Seal
  - Bottom Allen Bolt Gasket
- Install the following parts onto the inner tube.
  - Dust Seal
  - Oil Seal
  - Washer

- Insert the inner tube into the outer tube, and install the washer.
- Install the oil seal using the fork oil seal driver [A].

**Special Tool – Fork Oil Seal Driver,  $\Phi 43$ : 57001-1340**

- Install the retaining ring and dust seal [B] by hand.

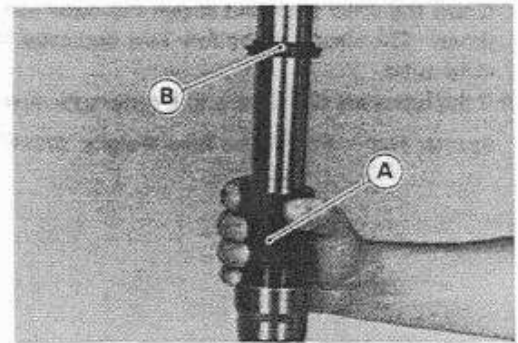

- Install the piston cylinder unit in the inner tube.
- Stop the cylinder from turning by using the fork cylinder holder.

**Special Tool – Fork Cylinder Holder: 57001-1396**

- Apply a non-permanent locking agent to the threads of the Allen bolt and tighten it.

**Torque – Front Fork Bottom Allen Bolt: 39 N-m (4.0 kg-m, 29 ft-lb)**

- Pour in the specified of oil (see Fork Oil Change).

**Recommended Oil: KAYABA 01 (SAE5W)**

**Fork Oil Capacity (completely dry): 495  $\pm$  4 mL**

### Front Fork Disassembly (ZX750P)

- Remove the front fork (see Front Fork Removal).
- Drain the fork oil (see Fork Oil Change).
- Hold the front fork in a vise [A].
- Stop the cylinder [B] from turning by using the fork cylinder holder [C].

**Special Tool – Fork Cylinder Holder: 57001-1297**

- Unscrew the Allen bolt [D], then remove the bolt and gasket out of the bottom of the inner tube.

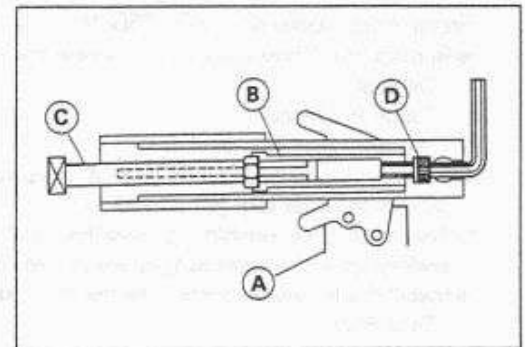

- Take the piston cylinder unit [A].
- Do not disassemble the piston cylinder unit.

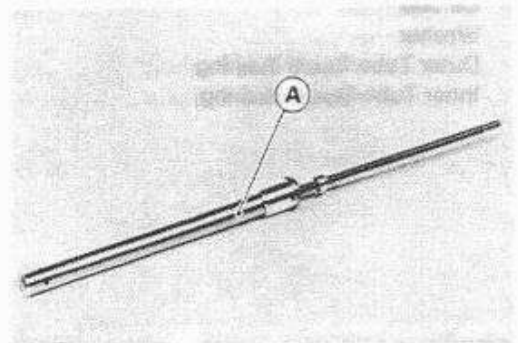

- Separate the inner tube from the outer tube as follows.
  - Slide up the dust seal [A].
  - Remove the retaining ring [B] from the outer tube.

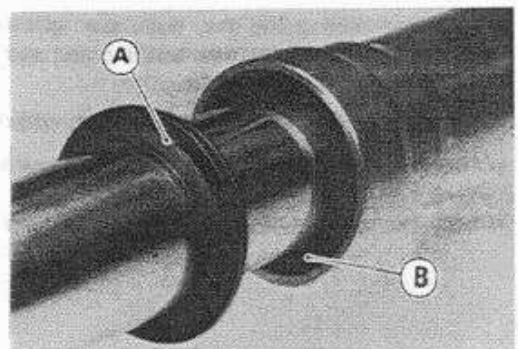

## 12-16 SUSPENSION

○ Grasp the inner tube and stroke the outer tube up and down several times. The shock to the fork seal separates the inner tube from the outer tube.

★ If the tubes are tight, use a fork outer tube weight [A].

**Special Tool – Fork Outer Tube Weight: 57001-1218**

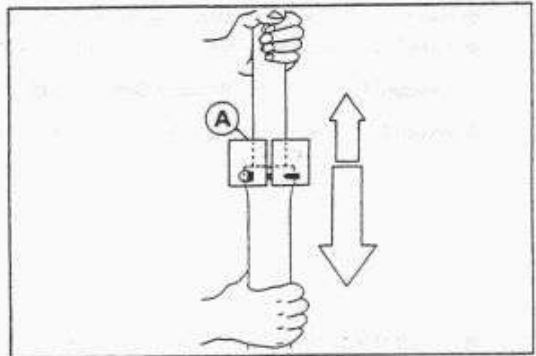

● Remove the inner tube guide bushing [A], outer tube guide bushing [B], washer [C], oil seal [D], retaining ring and dust seal from the inner tube.

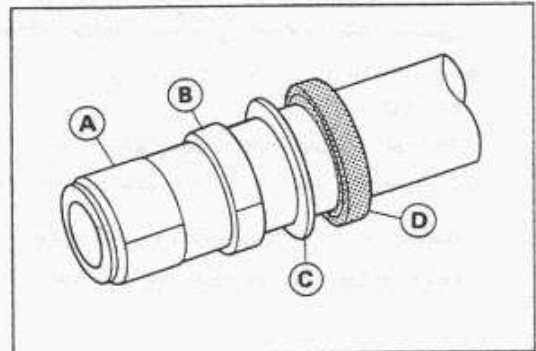

### Front Fork Assembly (ZX750P)

● Replace the following parts with new ones.

- Oil Seal
- Guide Bushings
- Bottom Allen Bolt Gasket

● Place an oil coated plastic bag [A] over the end of the inner tube to protect the dust seal [B] and oil seal.

○ The inner tube bushing groove has a sharp edge that can cut the sealing lip of the seals as they are pushed down over the inner tube.

● Install the following parts onto the inner tube.

- Dust Seal
- Retaining Ring
- Oil Seal
- Washer
- Outer Tube Guide Bushing
- Inner Tube Guide Bushing

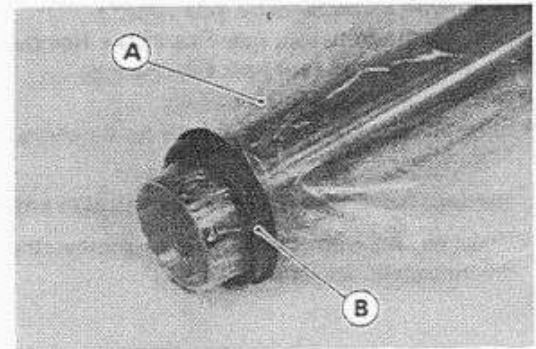

● When assembling the new outer tube guide bushing [A], hold the washer [B] against the new bushing and tap the washer with the fork oil seal driver [C] until it stops.

**Special Tool – Fork Oil Seal Driver,  $\phi 43$ : 57001-1340**

● After installing the washer, install the oil seal by using the fork oil seal driver.

● Install the retaining ring and dust seal by hand.

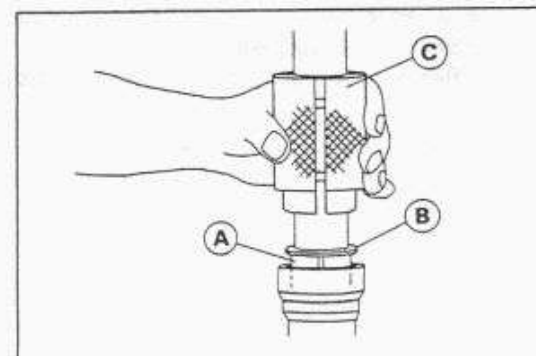



- Install the piston cylinder unit in the inner tube.
- Stop the cylinder from turning by using the fork cylinder holder.

**Special Tool – Fork Cylinder Holder: 57001-1297**

- Apply a non-permanent locking agent to the threads of the Allen bolt and tighten it.

**Torque – Front Fork Bottom Allen Bolt: 39 N-m (4.0 kg-m, 29 ft-lb)**

- Pour in the specified type of oil (see Fork Oil Change).

### Inner Tube Inspection

- Visually inspect the inner tube, and repair any damage.
- Nicks or rust damage can sometimes be repaired by using a wet-stone to remove sharp edges or raised areas which cause seal damage.
- ★ If the damage is not repairable, replace the inner tube. Since damage to the inner tube damages the oil seal, replace the oil seal whenever the inner tube is repaired or replaced.
- Temporarily assemble the inner and outer tubes, and pump them back and forth manually to check for smooth operation.

### CAUTION

If the inner tube is badly bent or creased, replace it. Excessive bending, followed by subsequent straightening, can weaken the inner tube.

### Dust Seal Inspection

- Inspect the dust seals [A] for any signs of deterioration or damage.
- ★ Replace it if necessary.

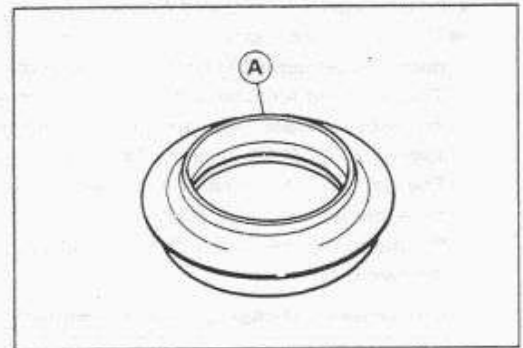

### Spring Tension

- Since a spring becomes shorter as it weakens, check its free length [A] to determine its condition.
- ★ If the spring of either fork leg is shorter than the service limit, it must be replaced. If the length of a replacement spring and that of the remaining spring vary greatly, the remaining spring should also be replaced in order to keep the fork legs balanced for motorcycle stability.

#### Fork Spring Free Length

**Standard:** 298.1 mm (ZX750N), 328.9 mm (ZX750P)  
**Service Limit:** 292 mm (ZX750N), 322 mm (ZX750P)

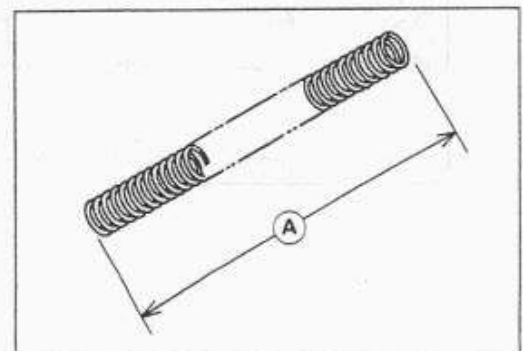

Rear Shock Absorber

*Rebound Damping Force Adjustment (ZX750N)*

- To adjust the rebound damping force, turn the rebound damping adjuster [A] until you feel a click.
- The standard adjuster setting for the average-build rider of 68 kg (150 lb) with no passenger and no accessories is the **8th click** from the 1st click of the fully clockwise position.

**Compression Damping Force Adjustment**

Adjuster Position	Damping Force	Setting	Load	Road	Speed
16 ~ 22	Weak	Soft	Light	Good	Low
↑	↑	↑	↑	↑	↑
↓	↓	↓	↓	↓	↓
1	Strong	Hard	Heavy	Bad	High

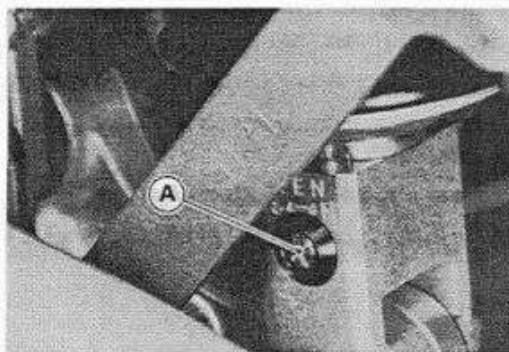

*Rebound Damping Force Adjustment (ZX750P)*

- To adjust the rebound damping force, turn the rebound damping adjuster [A] to the desired number [B] until you feel a click and the number aligns with the mark [C].
- The standard adjuster setting for an average-build rider of 68 kg (150 lb) with no passenger and no accessories is number **2**.
- ★ If the damping feels too soft or too stiff, adjust it.

**Rebound Damping Force Adjustment**

Adjuster Position	Damping Force	Setting	Load	Road	Speed
1	Weak	Soft	Light	Good	Low
↑	↑	↑	↑	↑	↑
↓	↓	↓	↓	↓	↓
4	Strong	Hard	Heavy	Bad	High

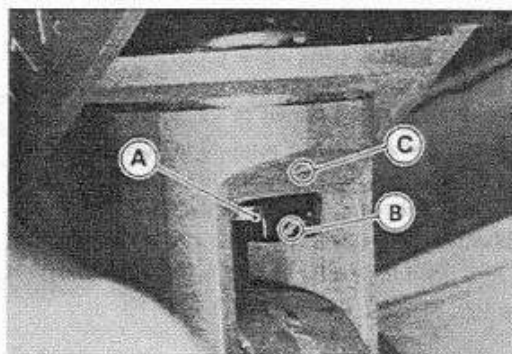

*Compression Damping Force Adjustment*

- To adjust the compression damping force, turn the compression damping adjuster [A] on the gas reservoir until you feel a click.
- The standard adjuster setting for the average-build rider of 68 kg (150 lb) with no passenger and no accessories is the **17th click (ZX750N)**, **15th click (ZX750P)** from the 1st click of the fully clockwise position.
- The damping force can be left soft for average riding. But it should be adjusted harder for high speed riding or riding with a passenger. If the damping feels too soft or too stiff, adjust it in accordance with the following table.

**Compression Damping Force Adjustment**

Adjuster Position	Damping Force	Setting	Load	Road	Speed
16 ~ 22	Weak	Soft	Light	Good	Low
↑	↑	↑	↑	↑	↑
↓	↓	↓	↓	↓	↓
1	Strong	Hard	Heavy	Bad	High

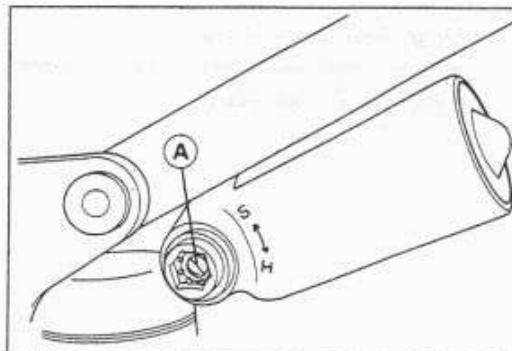

**Spring Preload Adjustment**

- Remove the rear shock absorber from the frame (see Rear Shock Absorber Removal).
- Loosen the locknut and turn out the adjusting nut to free the spring.

**Special Tool – Steering Stem Nut Wrenches: 57001 1100 (2)**

- Measure the spring free length.

- To adjust the spring preload, turn in the adjusting nut [A] to the desired position and tighten the locknut [B].
- [C] Spring Length

**Spring Preload Setting**

**Standard:** Spring free length minus 13 mm  
**Usable Range:** Spring free length minus 0 to 28 mm (ZX750N),  
 20.5 mm (ZX750P) (weaker to stronger)

- The standard adjusting nut setting for an average-build rider of 68 kg (150 lb) with no passenger and no accessories is compressed 12mm than free length.
- ★ If the spring action feels too soft or too stiff, adjust it.

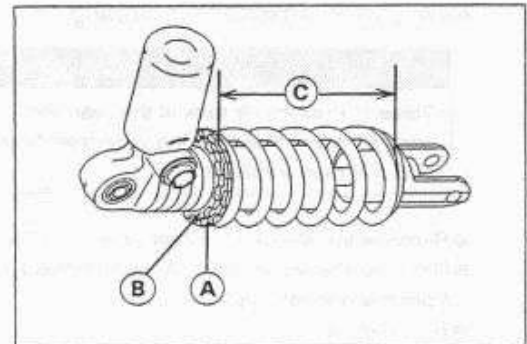

**Spring Adjustment**

Adjuster Position	Damping Force	Setting	Load	Road	Speed
0 mm	Weak	Soft	Light	Good	Low
↑	↑	↑	↑	↑	↑
↓	↓	↓	↓	↓	↓
28 mm (N) 20.5 mm (P)	Strong	Hard	Heavy	Bad	High

(N): ZX750N

(P): ZX750P

**Rear Shock Absorber Removal**

- Remove:
  - Seats (see Frame chapter)
  - Side Covers (see Frame chapter)
  - Fuel Tank (see Fuel System chapter)
  - Battery Case (see Frame chapter)
  - Lower Fairings (see Frame chapter)
- Remove:
  - Right Lower Fairing Stay
  - Side Stand
- Using the jack, raise the rear wheel off the ground.

**Special Tool – Jack: 57001-1238**

- Remove:
  - Lower Shock Absorber Bolt [A]
  - Upper Shock Absorber Bolt [B]
- Remove the shock absorber toward the upper.

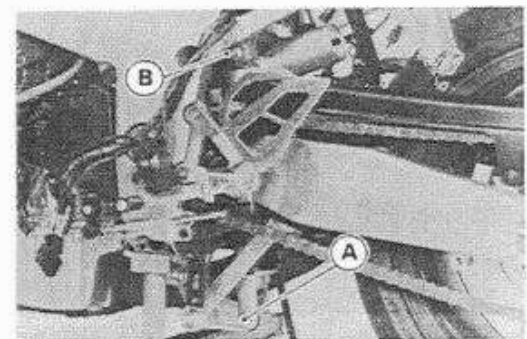

### Rear Shock Absorber Installation

- Pack the rocker arm needle bearing with molybdenum disulfide grease.
- Tighten the shock absorber nuts:

**Torque – Rear Shock Absorber Nuts: 59 N-m (6.0 kg-m, 43 ft-lb)**

### Rear Shock Absorber Scrapping

#### ⚠ WARNING

Since the reservoir tank of the rear shock absorber contains nitrogen gas, do not incinerate the reservoir tank without first releasing the gas or it may explode.

- Remove the shock absorber (see Rear Shock Absorber Removal).
- Remove the valve cap [A] and release the nitrogen gas completely from the gas reservoir.
- Remove the valve.

#### ⚠ WARNING

Since the high pressure gas is dangerous, do not point the valve toward your face or body.

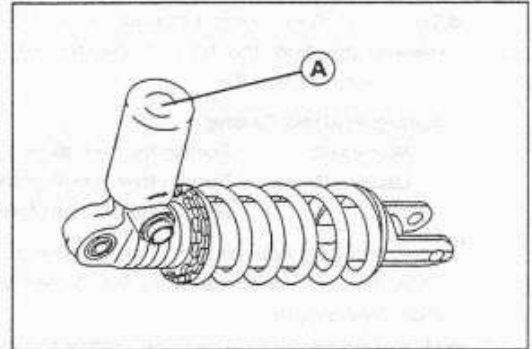

## Swingarm

### Swingarm Removal

● Remove:

- Rear Wheel (see Wheels/Tires chapter)
- Battery Case (see Frame chapter)
- Left Footpeg Bracket, Shift Pedal
- Chain Cover
- Brake Hose Clamps [A]

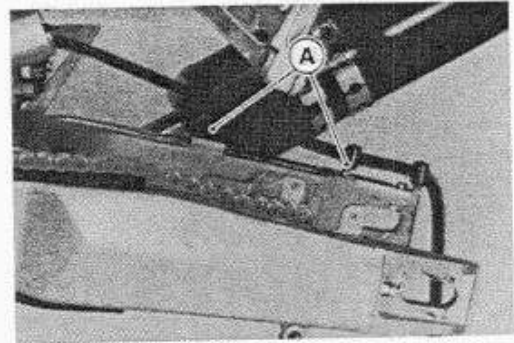

- Loosen the upper shock absorber nut [A].

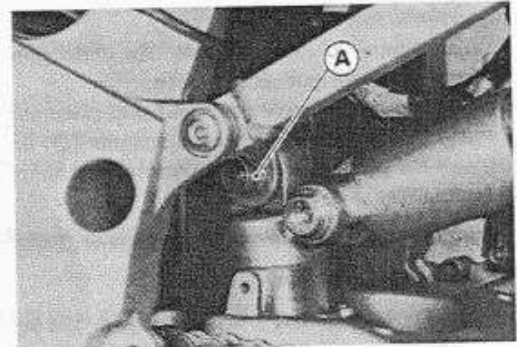

● Remove:

- Upper Tie-Rod Bolt [A]
- Lower Shock Absorber Bolt [B]

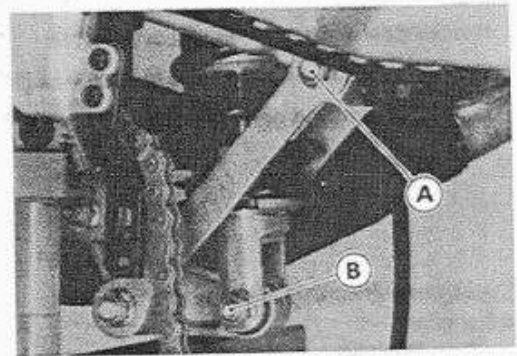

- Unscrew the swingarm pivot locknut [A], using the socket wrench [B].

**Special Tool – Socket Wrench: 57001-1370**

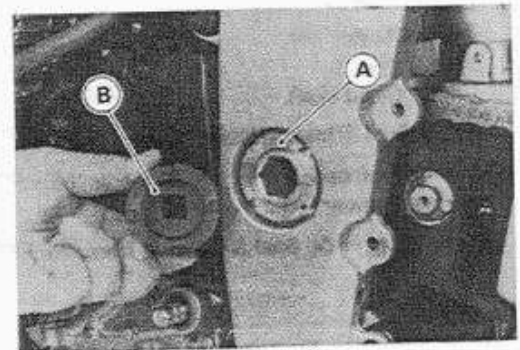

- Unscrew the swingarm pivot nut [A], and loosen the swingarm pivot shaft [B].
- Pull off the pivot shaft and remove the swingarm.

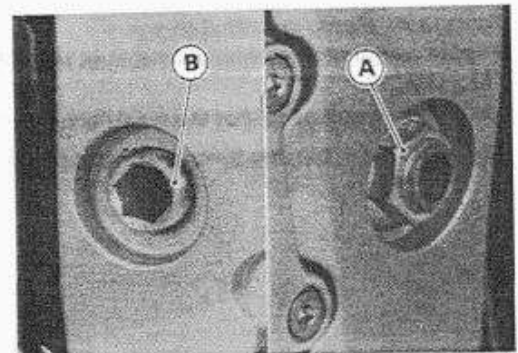

- Remove the left collar [A] and right collar [B] from the swingarm.

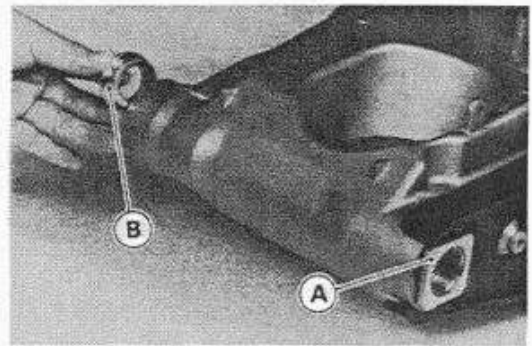

### Swingarm Installation

- Apply plenty of molybdenum disulfide grease to the ball bearing, needle bearings and grease seals.
- Install the collars, swingarm [A] and pivot shaft [B] as shown.
- Place the left collar [C] on the stopper [D] inside the frame [E].
- Insert the pivot shaft into the frame from the left side.
- Tighten the pivot shaft.

**Torque – Swingarm Pivot Shaft: 20 N-m (2.0 kg-m, 14.5 ft-lb)**

- Tighten the pivot nut.

**Torque – Swingarm Pivot Nut: 98 N-m (10.0 kg-m, 72 ft-lb)**

- Tighten the pivot lock nut [F] using the socket wrench.

**Special Tool – Socket Wrench: 57001-1370**

**Torque – Swingarm Pivot Lock Nut: 98 N-m (10.0 kg-m, 72 ft-lb)**

- Install the removed parts (see appropriate chapters).

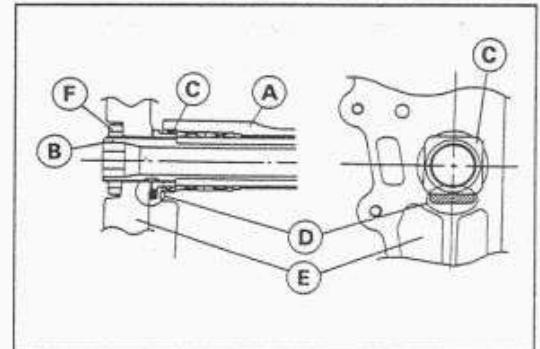

### Swingarm Bearing Removal

- Remove:
  - Swingarm
  - Collars
  - Grease Seals
  - Sleeve
  - Circlip (right side)

**Special Tool – Inside Circlip Pliers: 57001-143**

- Remove the ball bearing and needle bearings using the oil seal & bearing remover [A].

**Special Tool – Oil Seal & Bearing Remover: 57001-1058**

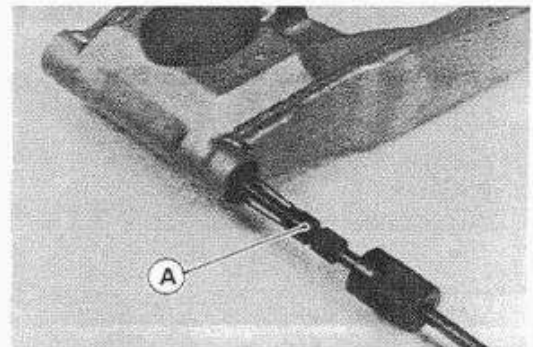

### Swingarm Bearing Installation

- Apply plenty of molybdenum disulfide to the ball bearing and needle bearings.
- Install the bearings so that the manufacturer's marks face out.

**Special Tool – Bearing Driver Set: 57001-1129 [A]**

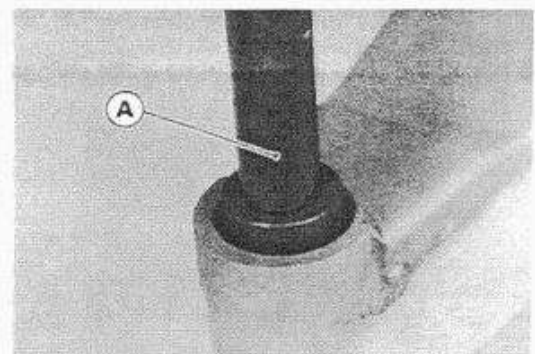

## Tie-Rod, Rocker Arm

### Tie-Rod Removal

- Remove:
  - Upper and Lower Fairings (see Frame chapter)
  - Radiator (see Cooling System chapter)
  - Muffler (see Engine Top End chapter)
- Using the jack, raise the rear wheel off the ground.

**Special Tool – Jack: 57001-1238**

- Remove the upper tie-rod bolt [A] and lower tie-rod bolt [B], and take out the tie-rods [C].

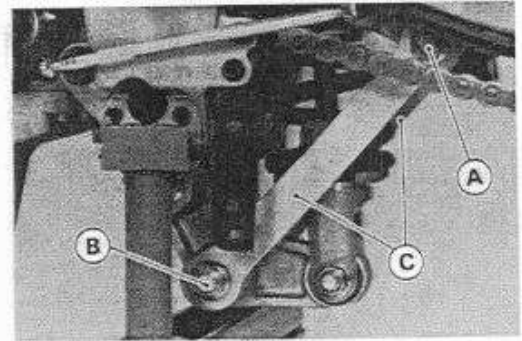

### Tie-Rod Installation

- Apply molybdenum disulfide grease to the inside of the needle bearings and oil seals.
- Tighten the upper and lower tie-rod bolts.

**Torque – Tie-Rod Nuts: 59 N-m (6.0 kg-m, 43 ft-lb)**

### Rocker Arm Removal

- Remove:
  - Upper and Lower Fairings (see Frame chapter)
  - Radiator (see Cooling System chapter)
  - Muffler (see Engine Top End chapter)
- Using the jack, raise the rear wheel off the ground.

**Special Tool – Jack: 57001-1238**

- Remove:
  - Lower Rear Shock Absorber Bolt [A]
  - Lower Tie-Rod Bolt [B]
  - Rocker Arm Bolt [C]
  - Rocker Arm [D]

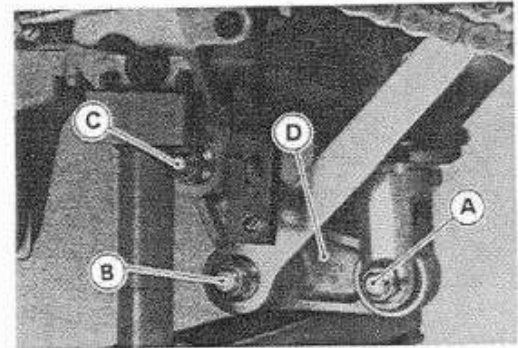

### Rocker Arm Installation

- Apply molybdenum disulfide grease to the inside of the needle bearings and oil seals.
- Tighten the rocker arm bolt, tie-rod bolt and shock absorber bolt.

**Torque – Rocker Arm Nut: 59 N-m (6.0 kg-m, 43 ft-lb)**

**Tie-Rod Nut: 59 N-m (6.0 kg-m, 43 ft-lb)**

**Rear shock Absorber Nut: 59 N-m (6.0 kg-m, 43 ft-lb)**

### *Needle Bearing Inspection*

★If there is any doubt as to the condition of either needle bearing, replace the bearing and sleeve as a set.

### *Tie-Rod, Rocker Arm Sleeve Inspection*

★If there is visible damage, replace the sleeve and needle bearing as a set.



# Steering

## Table of Contents

Exploded View .....	13-2
Specifications .....	13-3
Steering .....	13-4
Steering Inspection .....	13-4
Steering Adjustment .....	13-4
Steering Stem .....	13-5
Stem, Stem Bearing Removal .....	13-5
Stem, Stem Bearing Installation .....	13-5
Stem Bearing Lubrication .....	13-7
Handlebar .....	13-8
Handlebar Removal .....	13-8
Handlebar Installation .....	13-8

# 13-2 STEERING

## Exploded View

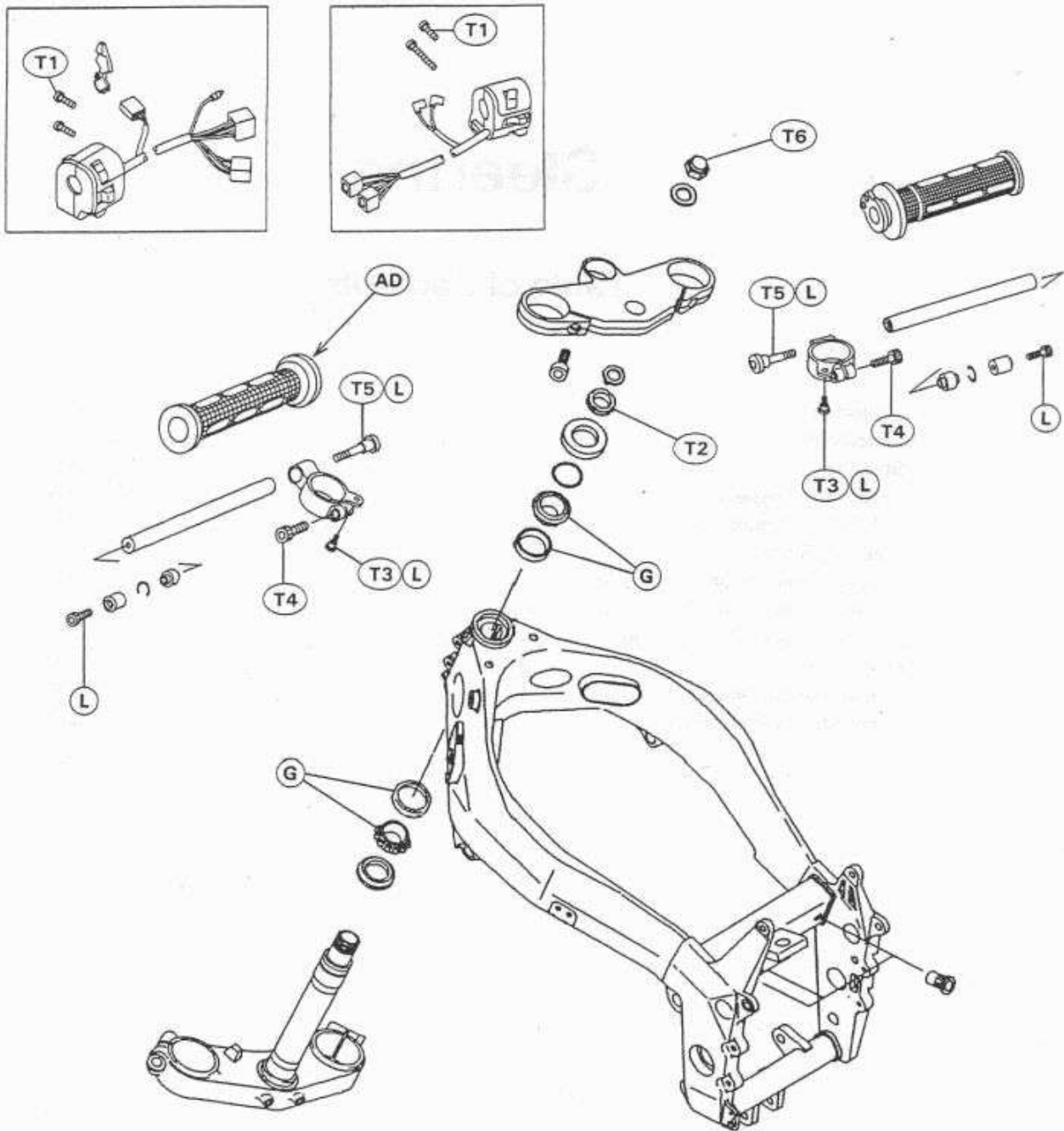

AD: Apply adhesive.  
G: Apply grease.  
L: Apply a non-permanent locking agent.

T1: 3.4 N-m (0.35 kg-m, 30 in-lb)  
T2: 4.9 N-m (0.50 kg-m, 43 in-lb)  
or Hand-tight  
T3: 9.8 N-m (1.0 kg-m, 87 in-lb)  
T4: 23 N-m (2.3 kg-m, 16.5 ft-lb)  
T5: 34 N-m (3.5 kg-m, 25 ft-lb)  
T6: 54 N-m (5.5 kg-m, 40 ft-lb)

Specifications

- Special Tool – Head Pipe Outer Race Press Shaft: 57001-1075
- Head Pipe Outer Race Drivers: 57001-1077 (2)
- Steering Stem Nut Wrench: 57001-1100
- Jack: 57001-1238
- Steering Stem Bearing Driver: 57001-1344
- Steering Stem Bearing Driver Adapter: 57001-1345

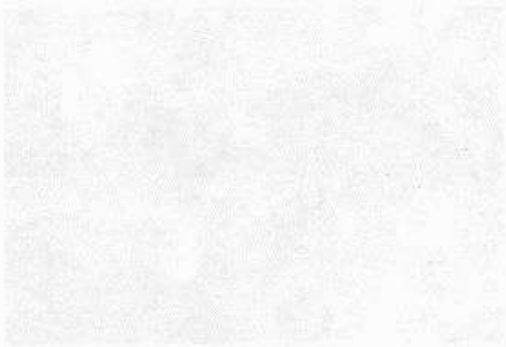

### Steering

#### Steering Inspection

- Check the steering.
- Lift the front wheel off the ground using the jack.

**Special Tool – Jack: 57001-1238**

- With the front wheel pointing straight ahead, alternately tap each end of the handlebar. The front wheel should swing fully left and right from the force of gravity until the fork hits the stop.
- ★ If the wheel binds or catches before the stop, the steering is too tight.
- Feel for steering looseness by pushing and pulling the forks.
- ★ If you feel looseness, the steering is too loose.

#### NOTE

- *The cables and wiring will have some effect on the motion of the fork which must be taken into account.  
Be sure the wires and cables are properly routed.*
- *The bearings must be in good condition and properly lubricated in order for any test to be valid.*

#### Steering Adjustment

- Remove:
  - Upper fairing (see Frame chapter)
  - Fuel Tank (see Fuel System chapter)
  - Rear View Mirror Bracket and Mounting Bolts
- Loosen:
  - Lower Fork Clamp Bolts (both sides)
  - Stem Head Nut [A]
- Adjust the steering.

**Special Tool – Steering Stem Nut Wrench: 57001-1100 [B]**

- ★ If the steering is too tight, loosen the stem nut a fraction of a turn.
- ★ If the steering is too loose, tighten the nut a fraction of a turn.

#### NOTE

- *Turn the stem nut 1/8 turn at a time maximum.*
- Tighten the steering stem head nut and lower fork clamp bolts.
  - Torque – Steering Stem Head Nut: 54 N-m(5.5 kg-m, 40 ft-lb)**
  - Lower Front Fork Clamp Bolts (ZX750N): 21 N-m (2.1 kg-m, 15.0 ft-lb)**
  - Lower Front Fork Clamp Bolts (ZX750P): 28 N-m (2.9 kg-m, 21 ft-lb)**
- Check the steering again.
- ★ If the steering is still too tight or too loose, repeat the adjustment.

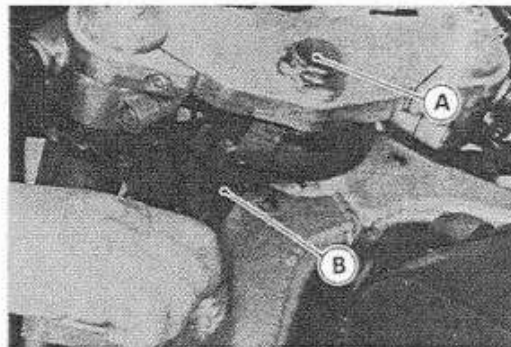

## Steering Stem

### Stem, Stem Bearing Removal

● Remove:

- Upper and lower Fairings (see Frame chapter)
- Fuel Tank (see Fuel System chapter)
- Rear View Mirror Bracket
- Front Wheel (see Wheels/Tires chapter)
- Front Fork (see Suspension chapter)
- Brake Hose Joint Mounting Bolts [A]
- Bolts [B] and Meter Bracket [C]
- Steering Stem Head Nut and Washer
- Steering Stem Head
- Horn Lead Connectors

- Pushing up the stem base, and remove the lock washer [A], stem nut [B], stem cap [C] and O-ring, then remove the steering stem [D] and stem base.

**Special Tool – Steering Stem Nut Wrench: 57001-1100**

● Remove:

- Upper Stem Bearing Inner Race
- Horn

- To remove the outer races [A] pressed into the head pipe [B], insert a bar [C] into the head pipe, and hammer evenly around the circumference of the opposite race to drive it out.

#### NOTE

○ If either steering stem bearing is damaged, it is recommended that both the upper and lower bearings (including outer races) should be replaced with new ones.

- Remove the lower stem bearing (with its grease seal) which is pressed onto the steering stem with a suitable commercially available bearing puller.

### Stem, Stem Bearing Installation

- Apply grease to the outer races, and drive them into the head pipe at the same time.

**Special Tool – Head Pipe Outer Race Press Shaft: 57001-1075 [A]**  
**Head Pipe Outer Race Drivers: 57001-1077 [B] (2)**

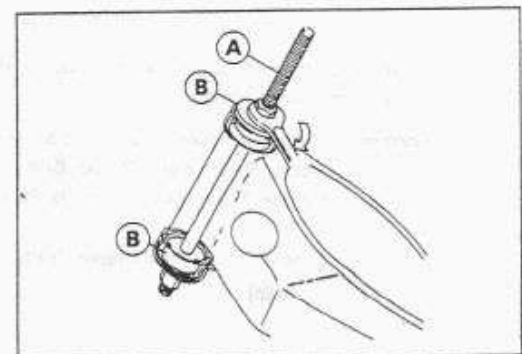
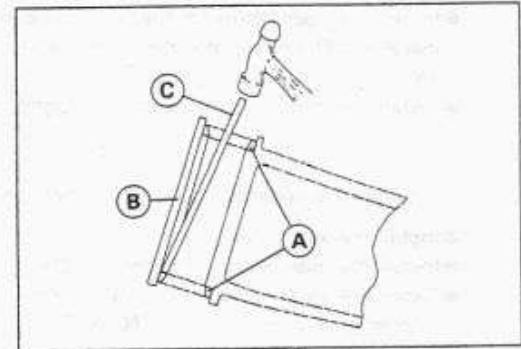
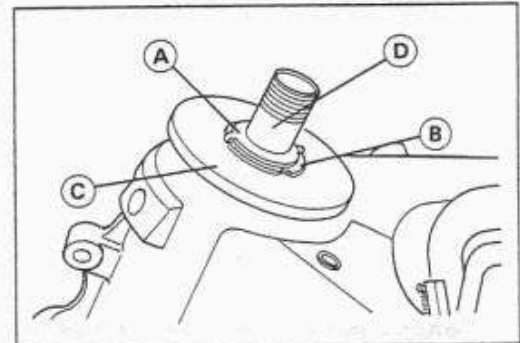
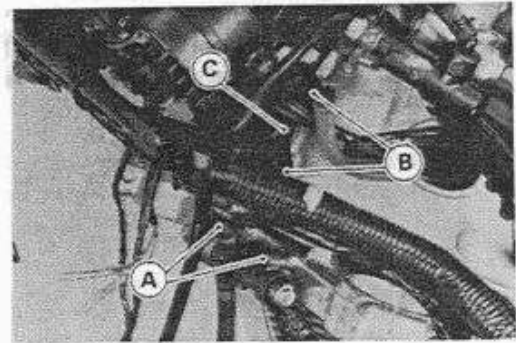

- Apply grease to the lower inner race [A], and drive it onto the stem.

**Special Tool – Steering Stem Bearing Driver: 57001-1344 [B]**

**Steering Stem Bearing Driver Adapter: 57001-1345 [C]**

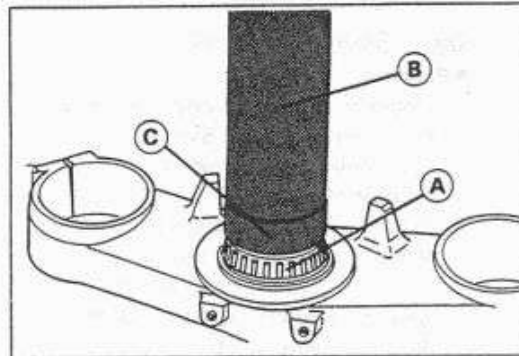

- Install the bolts [A] and horn [B] as shown.

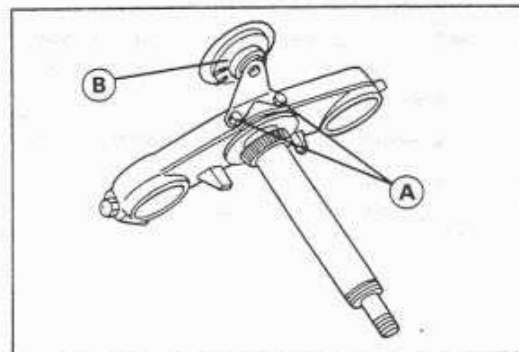

- Apply grease to the upper inner race, and install it in the head pipe.
- Apply grease to the O-ring.
- Install the stem through the head pipe and the upper inner race, and install the O-ring on the stem shaft while pushing up on the stem base [A].
- Install the stem cap [B], and hand tighten the stem nut [C].

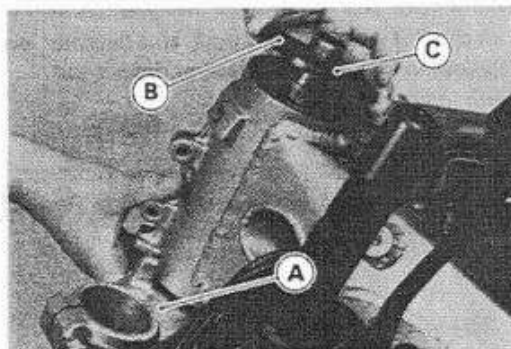

### NOTE

○ Install the steering stem nut so that the stepped side faces down.

- Install the stem head.
- Install the washer, and tighten the stem head nut lightly.
- Settle the inner races in place as follows:
  - Tighten the stem nut to 54 N-m (5.5 kg-m, 40 ft-lb) of torque. (To tighten the steering stem nut to the specified torque, hook the wrench on the stem nut, and pull the wrench at the hole by 30.5 kg [A] force in the direction shown.)

**Special Tool – Steering Stem Nut Wrench: 57001-1100 [B]**

- Check that there is no play and the steering stem turns smoothly without rattles. If not, the bearings on the inner races may be damaged.
- Again back out the stem nut a fraction of a turn until it turns lightly.
- Turn the stem nut lightly clockwise until it just becomes hard to turn. Do not overtighten, or the steering will be too tight.

**Torque – Steering Stem Nut: Hand-tight or 4.9 N-m (0.50 kg-m, 43 in-lb)**

- Install the front fork (see Suspension chapter).

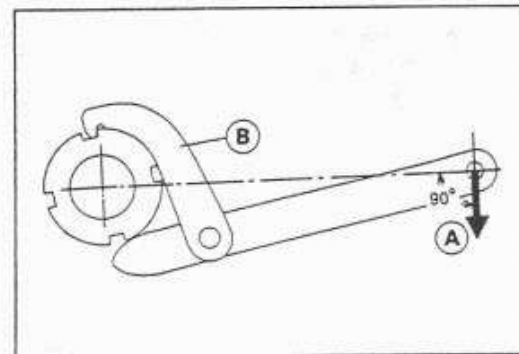

### NOTE

○ Tighten the fork upper clamp bolts first, next the stem head nut, last the fork lower clamp bolts.

**Torque – Steering Stem Head Nut : 54 N-m (5.5 kg-m, 40 ft-lb)**

**Upper Front Fork Clamp Bolts: 21 N-m (2.1 kg-m, 15 ft-lb)**

**Lower Front Fork Clamp Bolts (ZX750N): 21 N-m (2.1 kg-m, 15 ft-lb)**

**Lower Front Fork Clamp Bolts (ZX750P): 28 N-m (2.9 kg-m, 21 ft-lb)**

- Install the removed parts (see appropriate chapters).

**▲WARNING**

Do not impede the handlebar turning by routing the cables, harnesses and hoses improperly (see General Information chapter).

**Stem Bearing Lubrication**

- Remove the steering stem.
- Using a high flash-point solvent, wash the upper and lower tapered roller bearings in the cages, and wipe the upper and lower outer races, which are press-fitted into the frame head pipe, clean off grease and dirt.
- Visually check the outer races and the rollers.
- ★ Replace the bearing assemblies if they show wear or damage.
- Pack the upper and lower tapered roller bearings [A] in the cages with grease, and apply a light coat of grease to the upper and lower outer races.
- Install the steering stem, and adjust the steering.

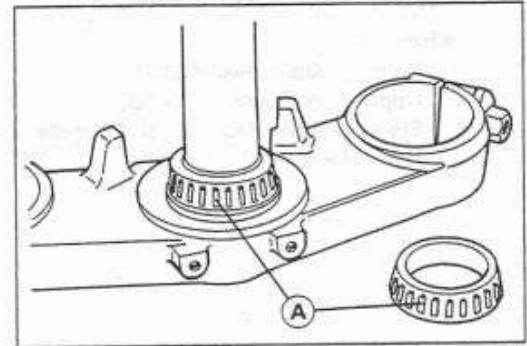

## Handlebar

### Handlebar Removal

- Remove:
  - Clutch Master Cylinder
  - Left Handlebar Switch Housing
  - Clutch Fluid Reservoir Bracket
  - Front Brake Fluid Reservoir Bracket
  - Front Brake Master Cylinder
  - Right Handlebar Switch Housing
  - Throttle Grip
  - Handlebar Bolts [A]
  - Handlebar Holder Bolts [B]
- Raise the front wheel off the ground.

**Special Tool – Jack: 57001-1238**

- Remove:
  - Steering Stem Head Nut [C]
  - Upper Fork Clamp Bolts [D]
  - Steering Stem Head [E] and Handlebar Holders [F]
  - Handlebars

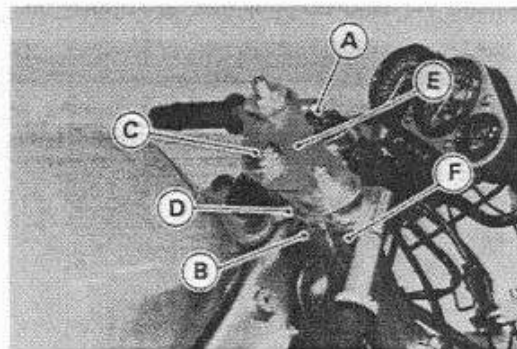

### Handlebar Installation

- Fit the pin [A] of the handlebar in the handlebar holder recess [B].
- Apply a non-permanent locking agent to the handlebar bolts and tighten the following bolts.

**Torque – Upper Front Fork Clamp Bolts: 21 N-m (2.1 kg-m, 15.0 ft-lb)**

**Handlebar Holder Bolts: 23 N-m (2.3 kg-m, 16.5 ft-lb)**

**Handlebar Bolts: 34 N-m (3.5 kg-m, 25 ft-lb)**

**Steering Stem Head Nut: 54 N-m (5.5 kg-m, 40 ft-lb)**

- Install the removed parts (see appropriate chapters).

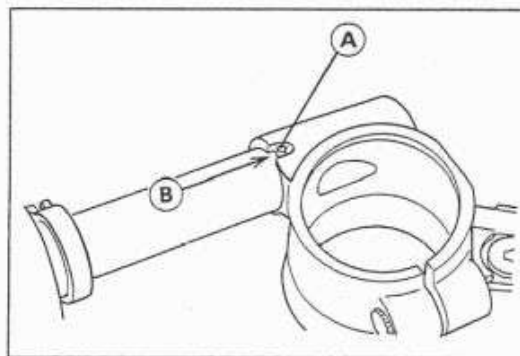



# Frame

## Table of Contents

Exploded View .....	14-2
Seats .....	14-5
Seat Removal (ZX750N) .....	14-5
Seat Installation (ZX750N) .....	14-5
Rear Seat Removal (ZX750P) .....	14-5
Rear Seat Installation (ZX750P) .....	14-5
Front Seat Removal (ZX750P) .....	14-6
Front Seat Installation (ZX750P) .....	14-6
Seat Cover (ZX750N) .....	14-7
Seat Cover Removal .....	14-7
Side Covers (ZX750P) .....	14-8
Side Cover Removal .....	14-8
Side Cover Installation .....	14-8
Fairings .....	14-9
Inner Fairing Removal .....	14-9
Inner Fairing Installation .....	14-9
Upper Fairing Removal .....	14-9
Lower Fairing Removal .....	14-9
Fenders .....	14-10
Front Fender Removal .....	14-10
Rear Fender Removal .....	14-10
Rear Fender Installation .....	14-10
Battery Case .....	14-11
Battery Case Removal .....	14-11
Rear Frame .....	14-12
Rear Frame Removal .....	14-12
Rear Frame Installation .....	14-12

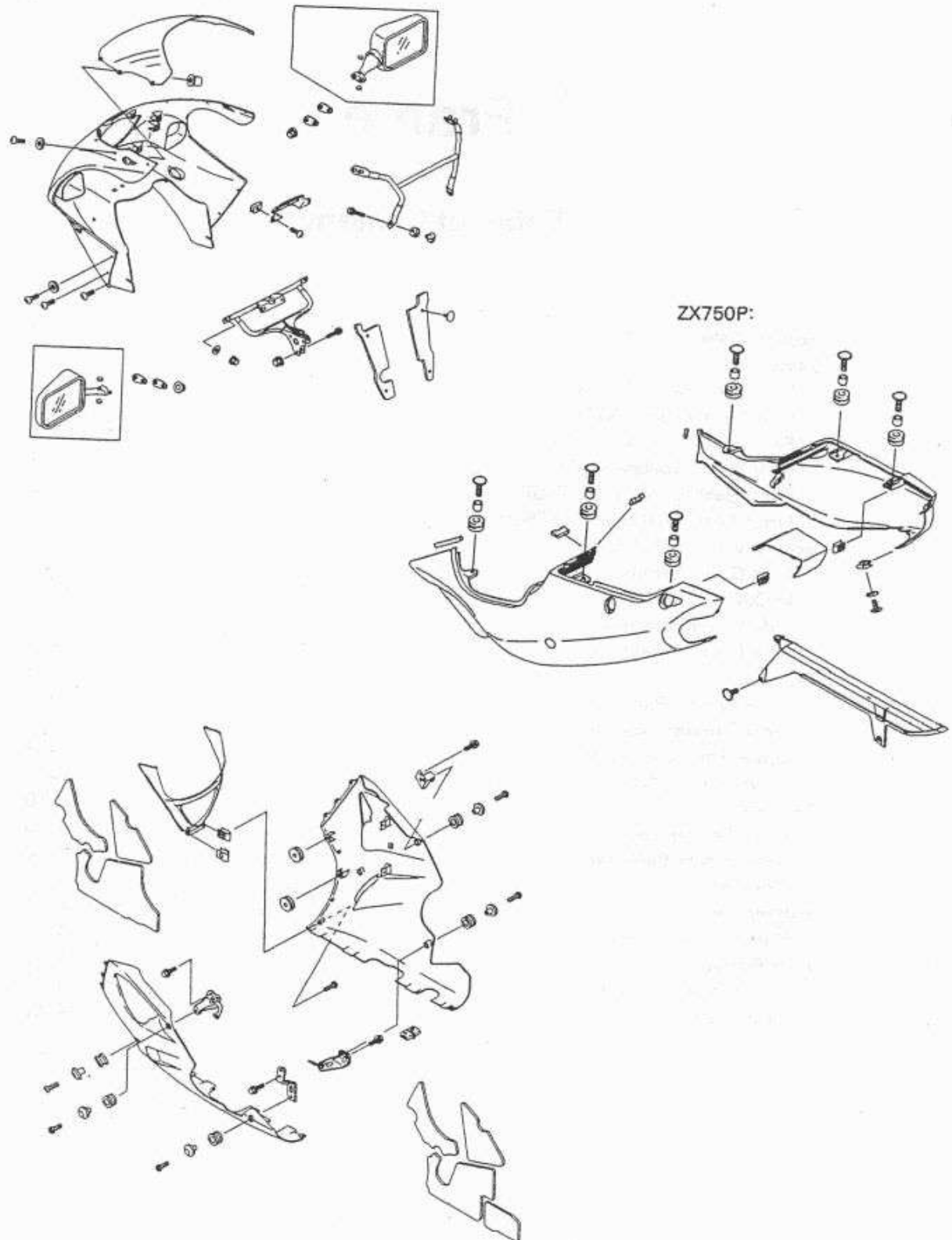

L: Apply a non-permanent locking agent.  
 O: Apply oil.

T1: 34 N-m (3.5 kg-m, 25 ft-lb)  
 T2: 44 N-m (4.5 kg-m, 33 ft-lb)  
 T3: 49 N-m (5.0 kg-m, 36 ft-lb)  
 T4: 59 N-m (6.0 kg-m, 43 ft-lb)

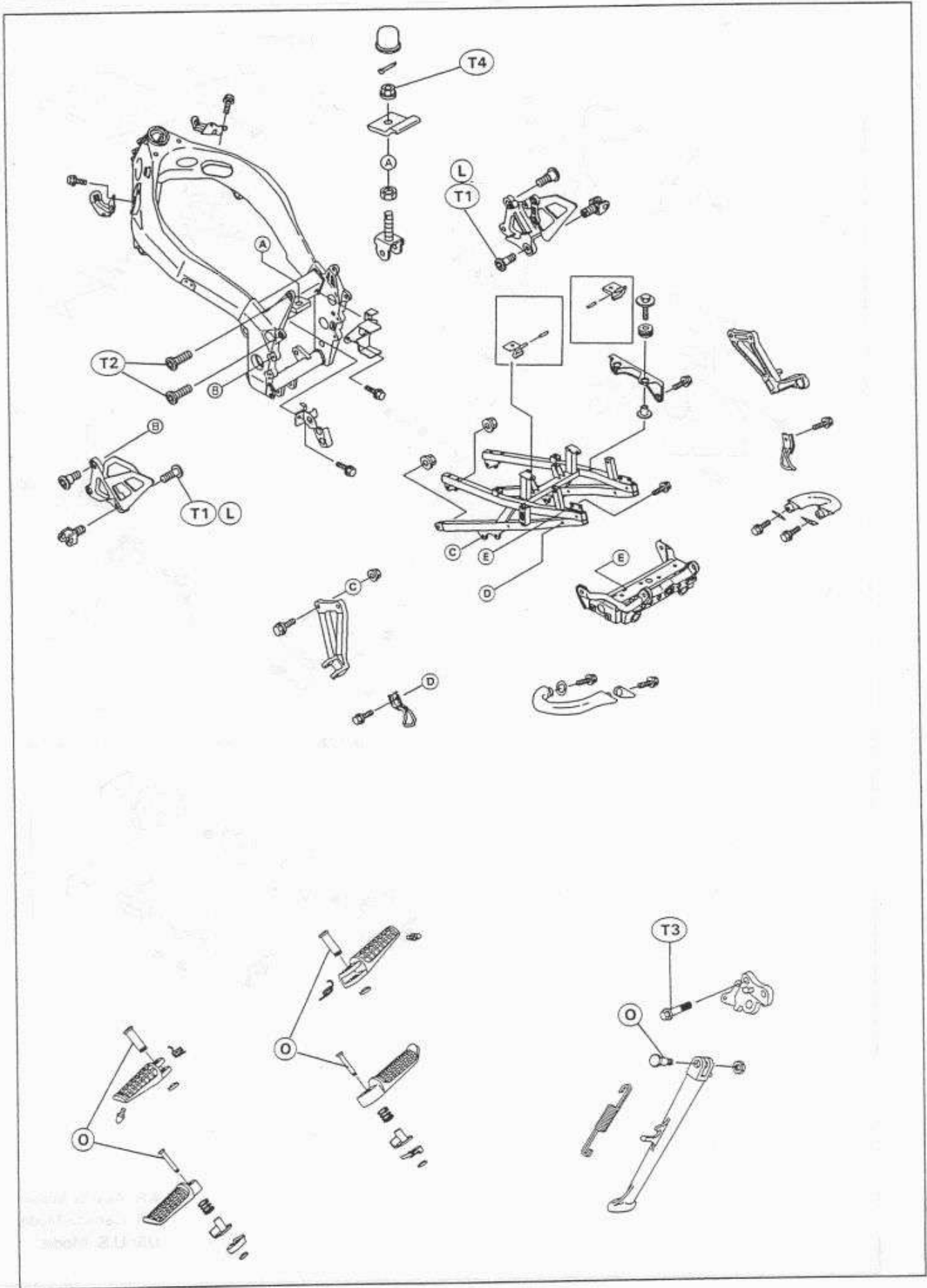

ZX750P:

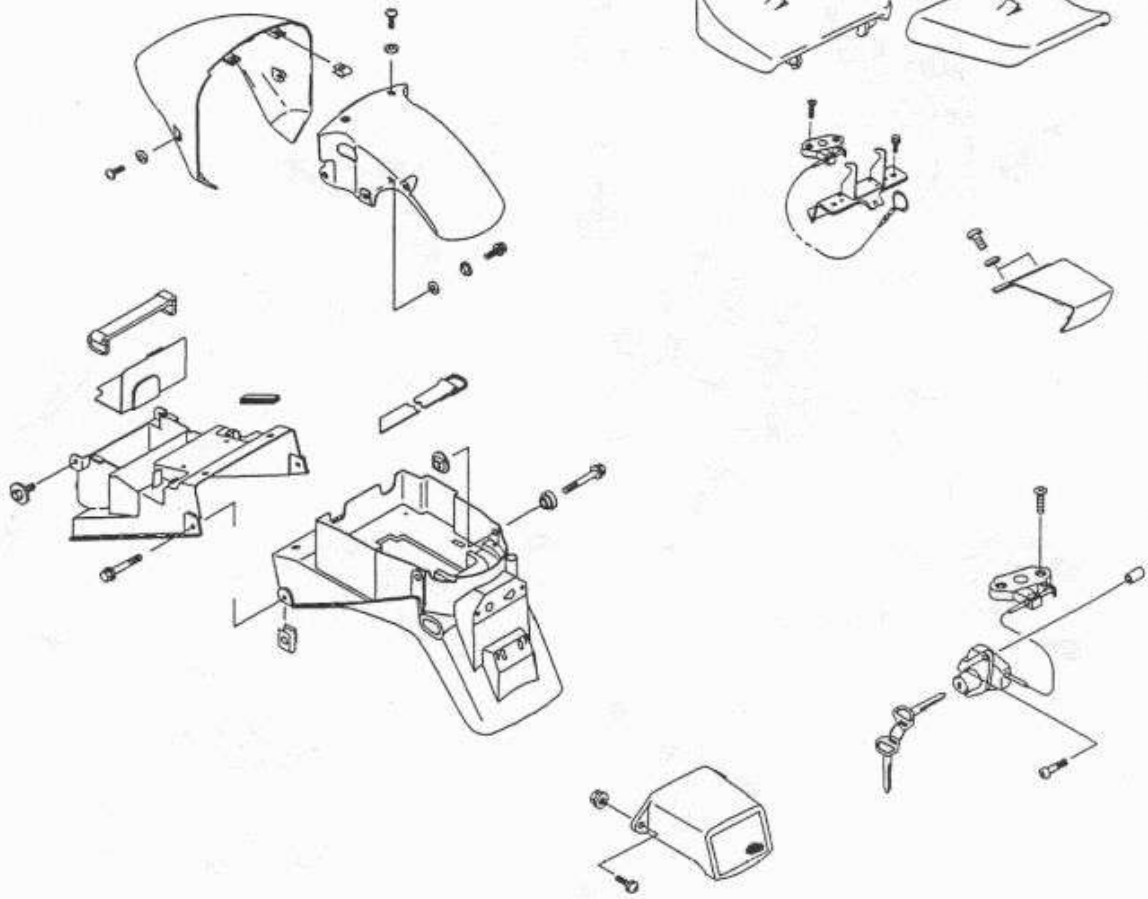

(AR,CN,US)

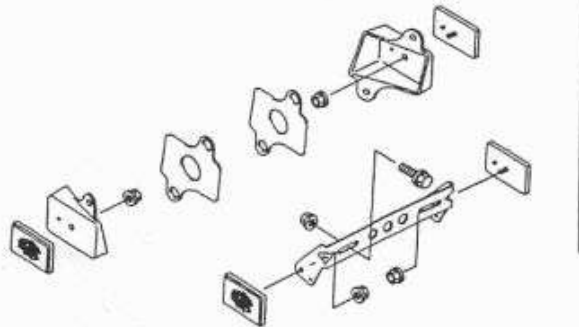

AR: Austria Model  
CN: Canada Model  
US: U.S. Model

## Seats

### Seat Removal (ZX750N)

- Insert the ignition switch key [A] into the seat lock, turning the key counterclockwise, pulling up on the rear of the seat [B].
- Remove the key from the seat lock.

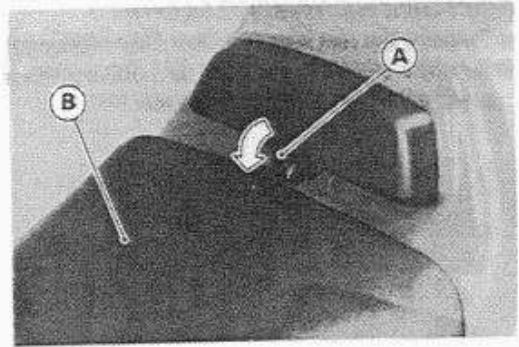

- Remove the seat by pulling up on the rear of the seat and pulling it backward.

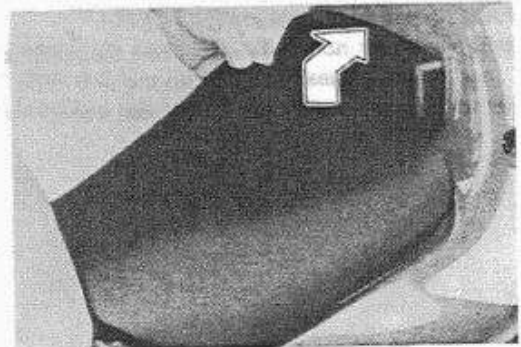

### Seat Installation (ZX750N)

- Slip the seat hook [A] under the brace [B] on the fuel tank bracket, and insert the seat pin [C] into the latch hole [D].
- Push down the rear part of the seat until the lock clicks.

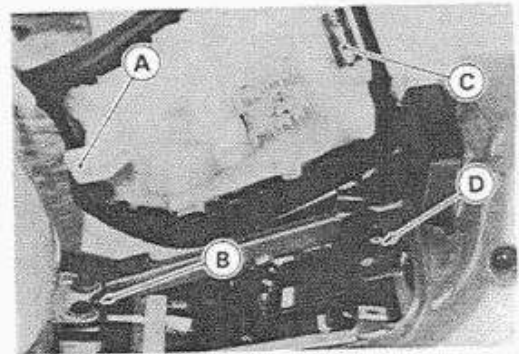

### Rear Seat Removal (ZX750P)

- Insert the ignition switch key [A] into the seat lock, turning the key counterclockwise, pulling up on the rear of the seat [B], and pulling it forward.

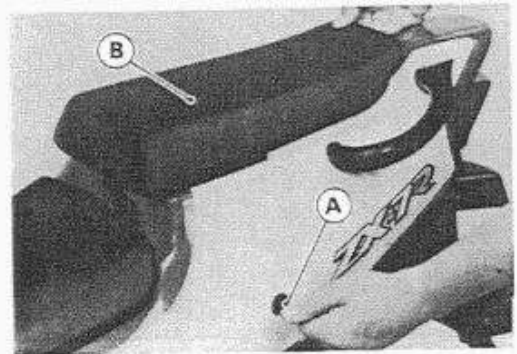

### Rear Seat Installation (ZX750P)

- Slip the rear loop [A] under the hooks [B] on the hook bracket.
- Insert the seat pin [C] into the latch hole [D].
- Push down the rear part of the seat until the lock clicks.

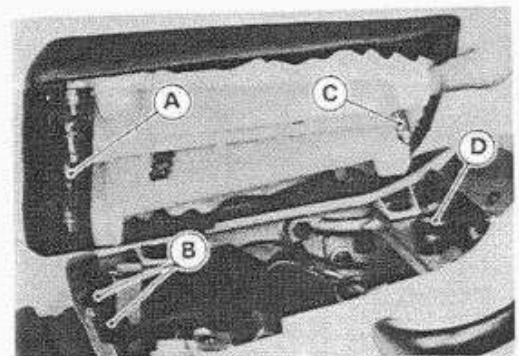

**Front Seat Removal (ZX750P)**

- Remove the rear seat (see Rear Seat Removal).
- Remove the front seat [A] by pulling the seat latch [B] and then pulling the seat up and to the rear.

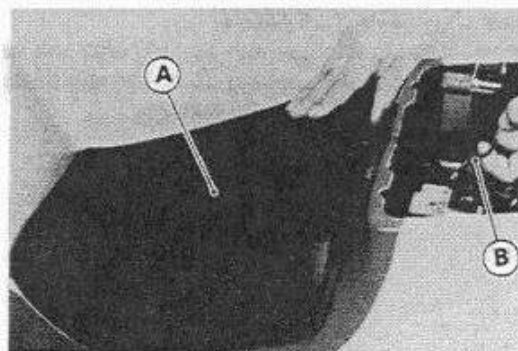

**Front Seat Installation (ZX750P)**

- Slip the seat hook [A] under the brace [B] on the fuel tank bracket, and insert the seat pin [C] into the latch hole [D].
- Push down the rear part of the seat until the lock clicks.

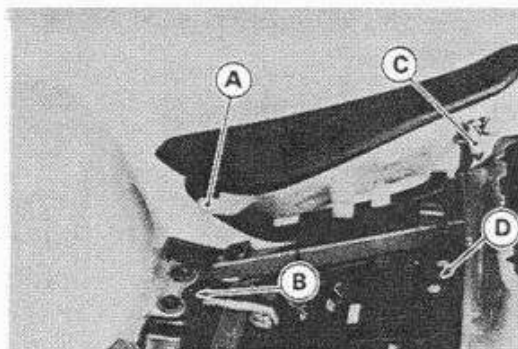

**Seat Cover (ZX750N)****Seat Cover Removal**

- Remove:
  - Seat (see Seat Removal)
  - Screws [A]
  - Screws and Lock [B]
  - Seat Cover [C]

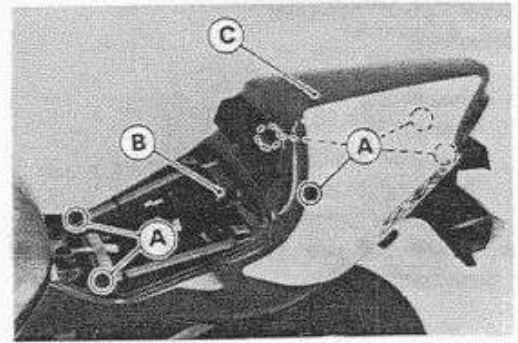

## Side Covers (ZX750P)

*Side Cover Removal*

- Remove:
  - Seats
  - Screws [A]
  - Clamps [B]
  - Grab Rail Bracket Bolts [C]
  - Screws and Lock [D]
  - Tail/Brake Lights Lead Connector
- Remove the side cover with the tail/brake lights and grab rails backward.

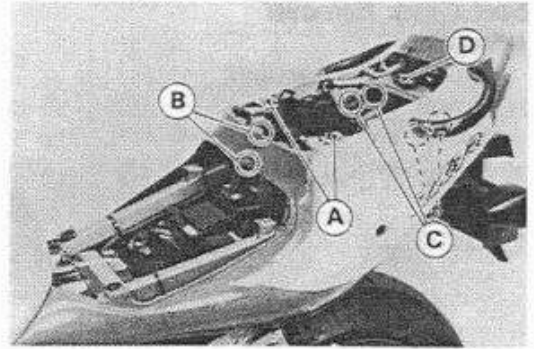

- Remove:
  - Upper Side Screws [A]
  - Under Side Screw [B]

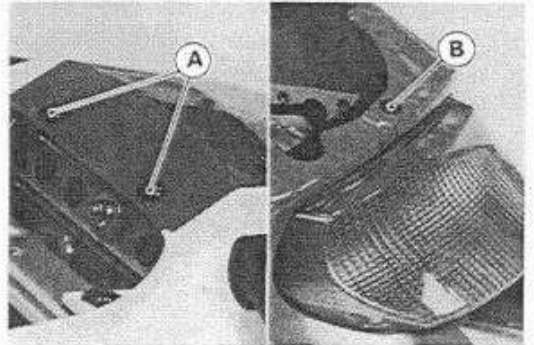

- Pull the front part of the center cover [A] upward and backward to clear the stoppers [B].

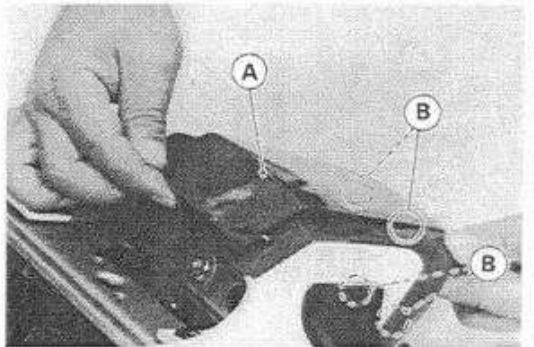

- Remove:
  - Grab Rail Bolts [A]
  - Grab Rail [B]
  - Side Cover [C]

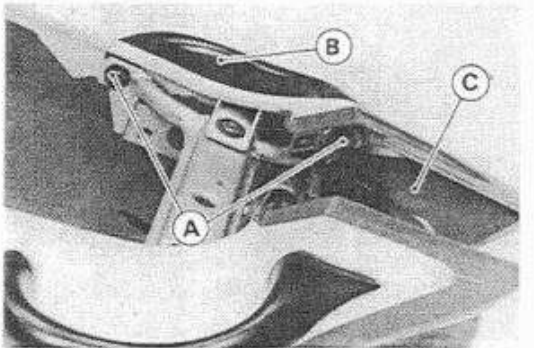
*Side Cover Installation*

- Fit the stoppers [A] of the center cover to the side covers and then fit the projections [B] into the slits [C] in the covers.

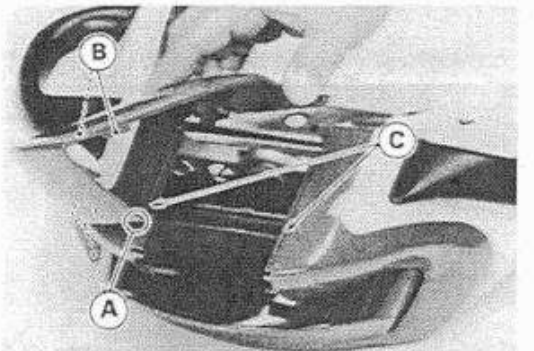



## Fairings

### Inner Fairing Removal

- Remove the screw [A], and pull the front part of the inner fairing [B] upward to clear the stopper
- Remove the inner fairing.
- Remove the other inner fairing in the same manner.

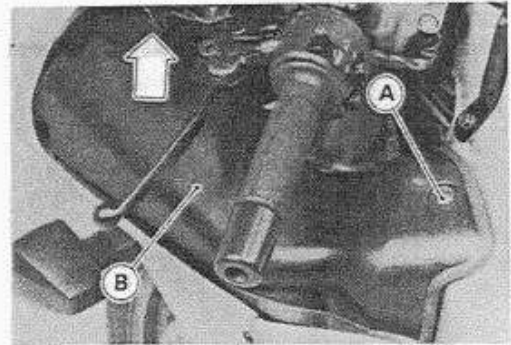

### Inner Fairing Installation

- Fit the projection [A] on the inner fairing into the hole [B] in the air intake duct [C].
- Install the screws.

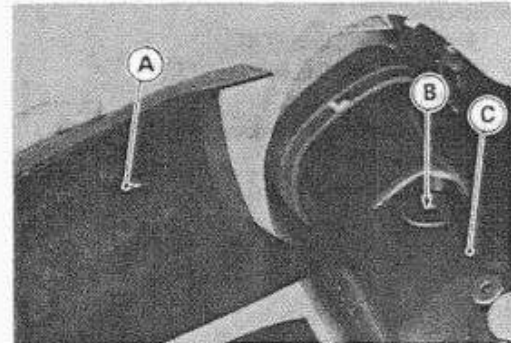

### Upper Fairing Removal

- Remove:
  - Inner Fairing
  - Rear View Mirrors [A]
  - Bracket Nuts [B]
  - Screws [C]
  - Headlight Connector
  - Turn Signal Light Lead Connectors
  - City Light Connector (other than US, Canada and Australia)
- Remove the upper fairing.

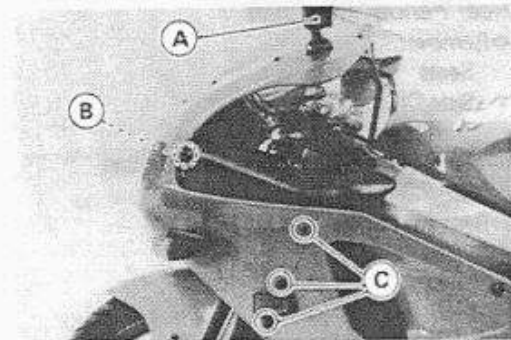

### Lower Fairing Removal

- Remove:
  - Screws [A] [B]
  - Allen Bolts [C]
  - Clamp [D]
- Remove the lower fairing.
- Remove the other lower fairing in the same manner.

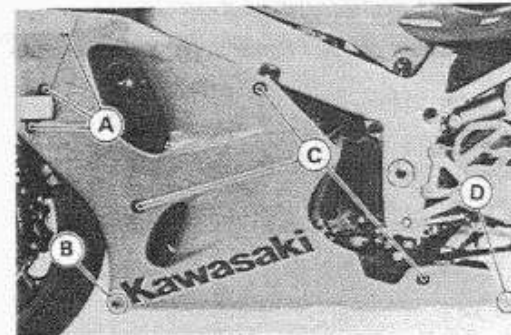

### NOTE

- When removing the left and right lower fairings at the same time, do not remove the screws [B] (both sides) and clamp [D].

## Fenders

*Front Fender Removal*

- Remove the screws [A] and take off the front fender front [B].

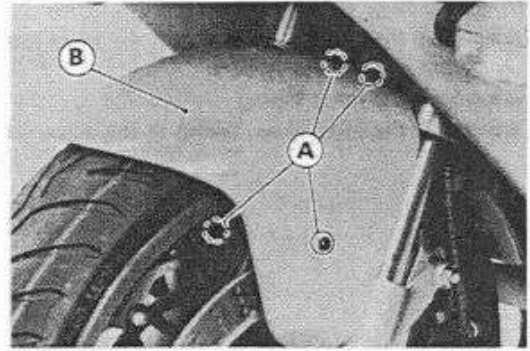

- Remove:
  - Brake Hose Clamps [A]
  - Speedometer Cable Clamp [B]
  - Bolts [C]
- Remove the front fender rear [D].

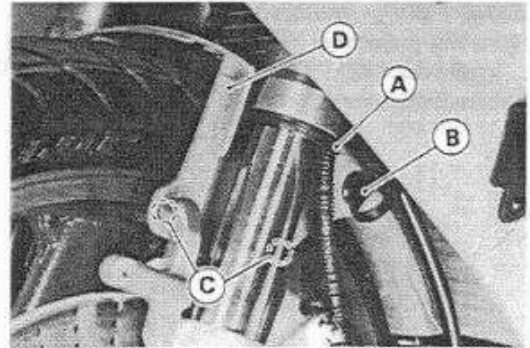
*Rear Fender Removal*

- Remove:
  - Seats
  - Side Covers
  - Turn Signal Relay
  - Turn Signal Light Lead Connectors
  - Bolts [A]
- Remove the rear fender [B].

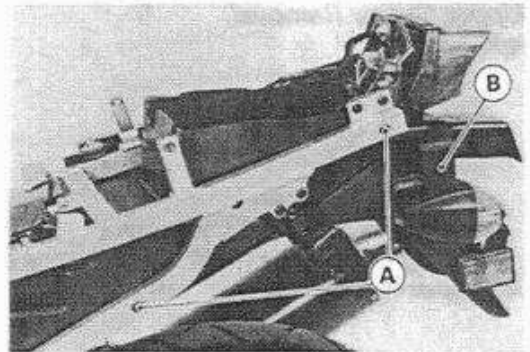
*Rear Fender Installation*

- Fasten the ground terminal [A] with the mounting bolt as shown.

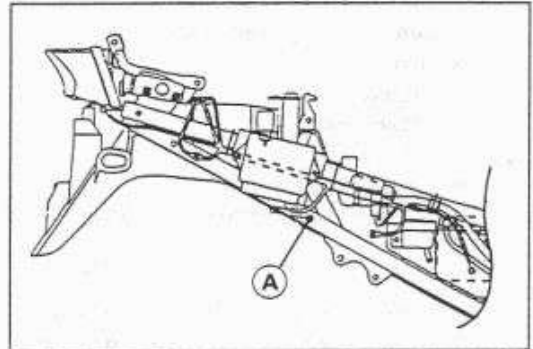

## Battery Case

### *Battery Case Removal*

- Remove:
  - Seats
  - Side Covers
  - Rear Fender
  - Junction Box
  - Starter Relay and Main Fuse
  - Turn Signal Relay
  - Fuel Pump Relay
  - Battery
  - Rear Brake Reservoir Mounting Bolt
  - Mounting Bolts [A]
  - Battery Case [B]

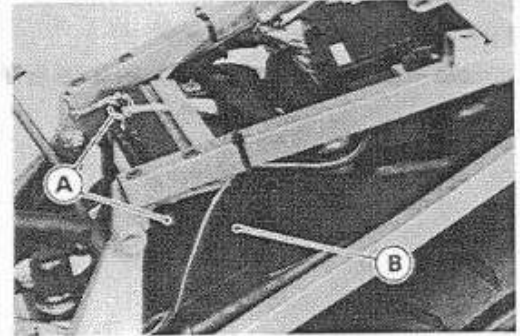

## Rear Frame

### *Rear Frame Removal*

● Remove:

- Rear Fender (see Rear Fender Removal)
- Battery Case (see Battery Case Removal)
- Frame Bolts and Nuts [A]

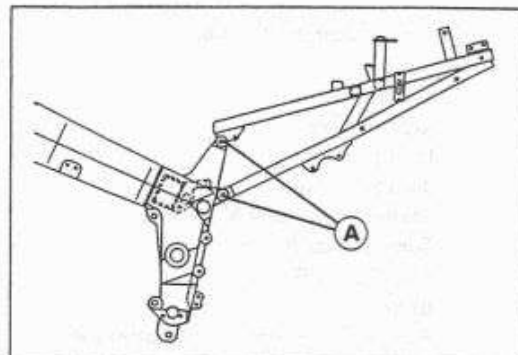

### *Rear Frame Installation*

● Tighten the frame bolts and nuts.

**Torque – Rear Frame Bolts and Nuts: 44 N-m (4.5 kg-m, 33 ft-lb)**

# Electrical System

## Table of Contents

Exploded View .....	15-2	Lighting System .....	15-33
Specifications .....	15-5	Headlight Beam Horizontal Adjustment .....	15-33
Parts Location .....	15-6	Headlight Beam Vertical Adjustment .....	15-33
Precautions .....	15-7	Headlight Bulb Replacement .....	15-33
Electrical Wiring .....	15-8	Headlight Diode Inspection	
Wiring Inspection .....	15-8	(Europe models except U.K.) .....	15-34
Battery .....	15-9	Turn Signal Relay Inspection .....	15-37
Charging Condition Inspection .....	15-9	Fuel Pump .....	15-39
Refreshing Charge .....	15-9	Removal/Installation .....	15-39
Alternator .....	15-11	Fuel Pump Relay Inspection .....	15-39
Alternator Removal .....	15-11	Fuel Pump Operational Inspection .....	15-39
Alternator Installation .....	15-11	Radiator Fan System .....	15-41
Alternator Disassembly .....	15-11	Fan System Circuit Inspection .....	15-41
Alternator Assembly .....	15-13	Fan Motor Inspection .....	15-41
Operational Inspection .....	15-15	Meters, Gauge .....	15-42
Test No. 1 - Battery Discharged .....	15-15	Meter, Gauge Removal .....	15-42
Test No. 2 - Battery Overcharged .....	15-16	Meter, Gauge Disassembly .....	15-42
Test No. 3 - Noise .....	15-16	Bulb Replacement .....	15-42
Stator Coil Inspection .....	15-16	Tachometer Inspection .....	15-42
Rotor Coil Inspection .....	15-16	Water Temperature Gauge Inspection .....	15-44
Slip Ring Cleaning .....	15-16	Switches and Sensors .....	15-45
Slip Ring Diameter .....	15-17	Brake Light Timing Inspection .....	15-45
Carbon Brush Length .....	15-17	Brake Light Timing Adjustment .....	15-45
Rectifier Inspection .....	15-17	Switch Inspection .....	15-45
Regulator Inspection .....	15-17	Radiator Fan Switch Inspection .....	15-46
Alternator Ball Bearing Inspection .....	15-18	Water Temperature Sensor Inspection .....	15-46
Ignition System .....	15-20	Throttle Switch Inspection (ZX750N) .....	15-46
Pickup Coil Removal .....	15-20	Fuel Enricher Solenoid Valve (ZX750N) .....	15-48
Pickup Coil Installation .....	15-20	Fuel Enricher Solenoid Valve Inspection .....	15-48
Pickup Coil Inspection .....	15-21	Junction Box .....	15-49
Ignition Coil Removal .....	15-21	Junction Box Fuse Circuit Inspection .....	15-49
Ignition Coil Installation .....	15-21	Starter Circuit/Headlight Relay Inspection .....	15-49
Ignition Coil Inspection .....	15-22	Diode Circuit Inspection .....	15-50
Spark Plug Removal .....	15-22	Fuse .....	15-52
Spark Plug Installation .....	15-23	30A Main Fuse Removal .....	15-52
Spark Plug Gap Inspection .....	15-23	Junction Box Fuse Removal .....	15-52
IC Igniter Inspection .....	15-23	Fuse Installation .....	15-52
Starter Motor .....	15-28	Fuse Inspection .....	15-52
Starter Motor Removal .....	15-28	ZX750N Wiring Diagram (US and Canada) .....	15-53
Starter Motor Installation .....	15-28	ZX750N Wiring Diagram (United Kingdom) .....	15-54
Starter Motor Disassembly .....	15-29	ZX750N Wiring Diagram	
Starter Motor Assembly .....	15-29	(European Models except United Kingdom) .....	15-55
Brush Inspection .....	15-30	ZX750P Wiring Diagram (US and Canada) .....	15-57
Commutator Cleaning and Inspection .....	15-30	ZX750P Wiring Diagram (Australia) .....	15-58
Armature Inspection .....	15-31	ZX750P Wiring Diagram (United Kingdom) .....	15-59
Brush Lead Inspection .....	15-31	ZX750P Wiring Diagram	
Brush Plate and Terminal Bolt Inspection .....	15-31	(European Models except United Kingdom) .....	15-60
Starter Relay Inspection .....	15-31		

Exploded View

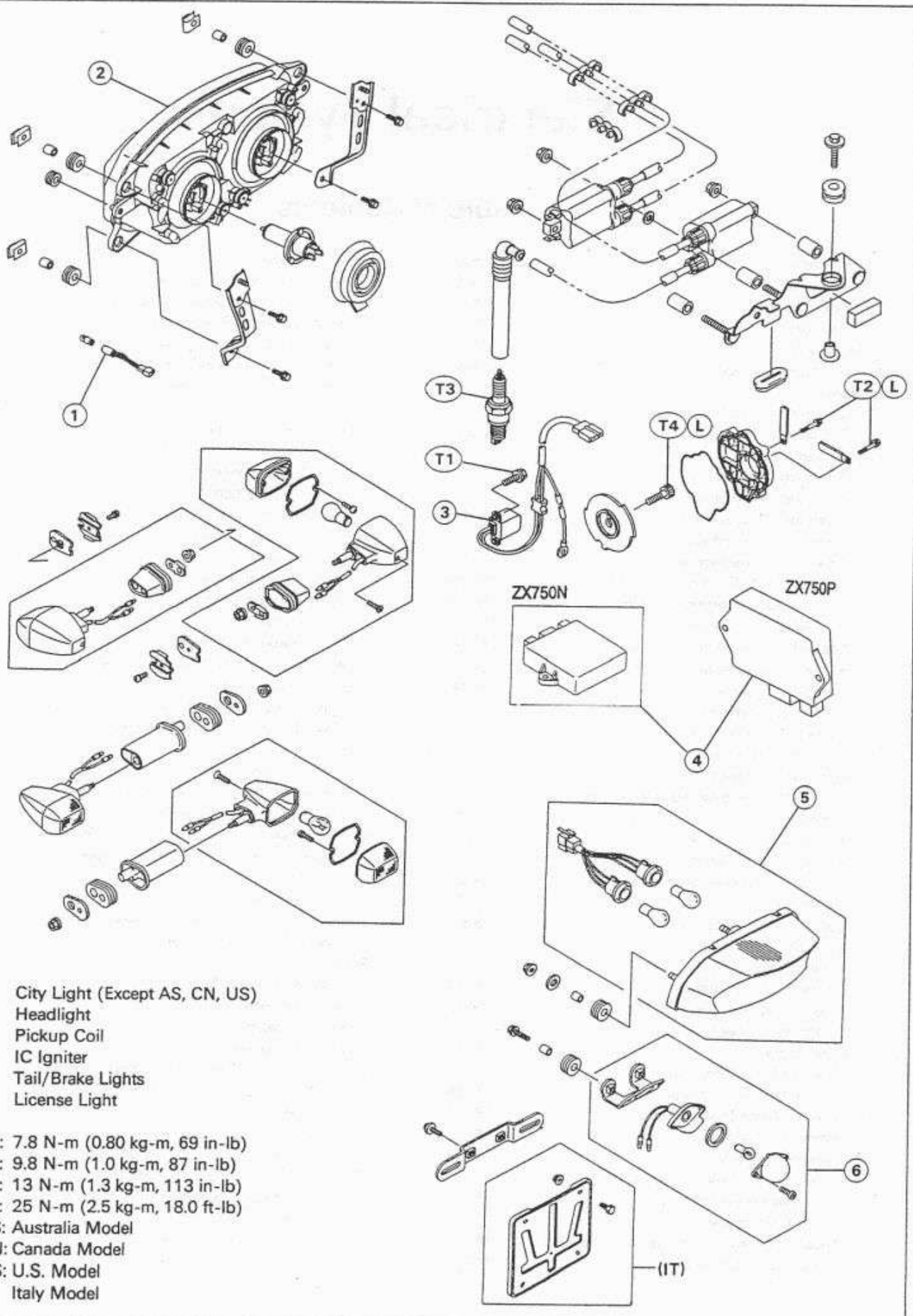

- 1. City Light (Except AS, CN, US)
- 2. Headlight
- 3. Pickup Coil
- 4. IC Igniter
- 5. Tail/Brake Lights
- 6. License Light

T1: 7.8 N-m (0.80 kg-m, 69 in-lb)  
 T2: 9.8 N-m (1.0 kg-m, 87 in-lb)  
 T3: 13 N-m (1.3 kg-m, 113 in-lb)  
 T4: 25 N-m (2.5 kg-m, 18.0 ft-lb)  
 AS: Australia Model  
 CN: Canada Model  
 US: U.S. Model  
 IT: Italy Model

1. Fuel Pump Relay
2. Fuel Pump
3. Starter Relay

EO: Apply engine oil.

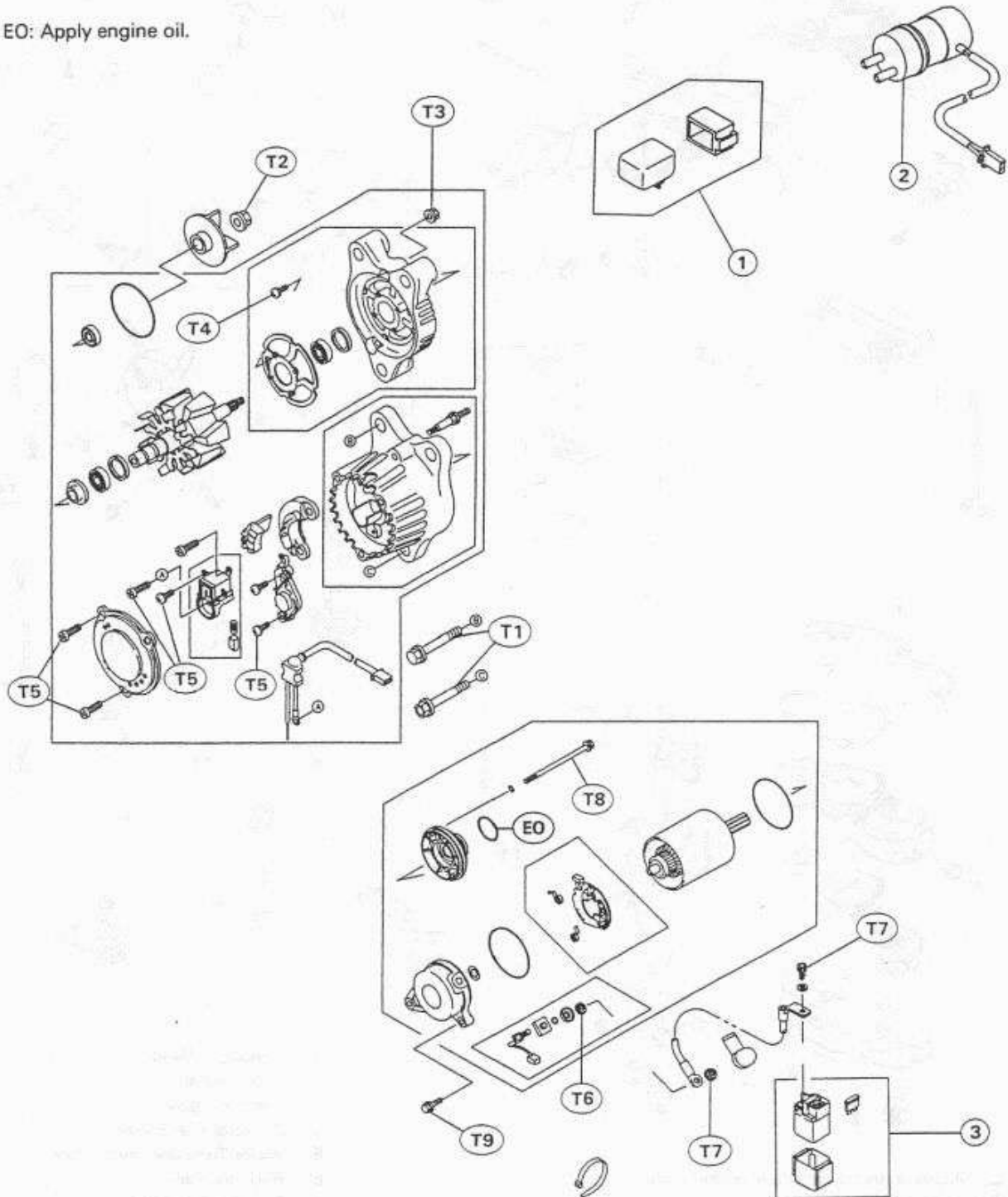

- T1: 25 N-m (2.5 kg-m, 18.0 ft-lb)
- T2: 54 N-m (5.5 kg-m, 40 ft-lb)
- T3: 4.4 N-m, (0.45 kg-m, 39 in-lb)
- T4: 2.5 N-m (0.25 kg-m, 22 in-lb)
- T5: 3.4 N-m (0.35 kg-m, 30 in-lb)

- T6: 11 N-m (1.1 kg-m, 95 in-lb)
- T7: 4.9 N-m (0.50 kg-m, 43 in-lb)
- T8: 5.9 N-m (0.60 kg-m, 52 in-lb)
- T9: 9.8 N-m (1.0 kg-m, 87 in-lb)

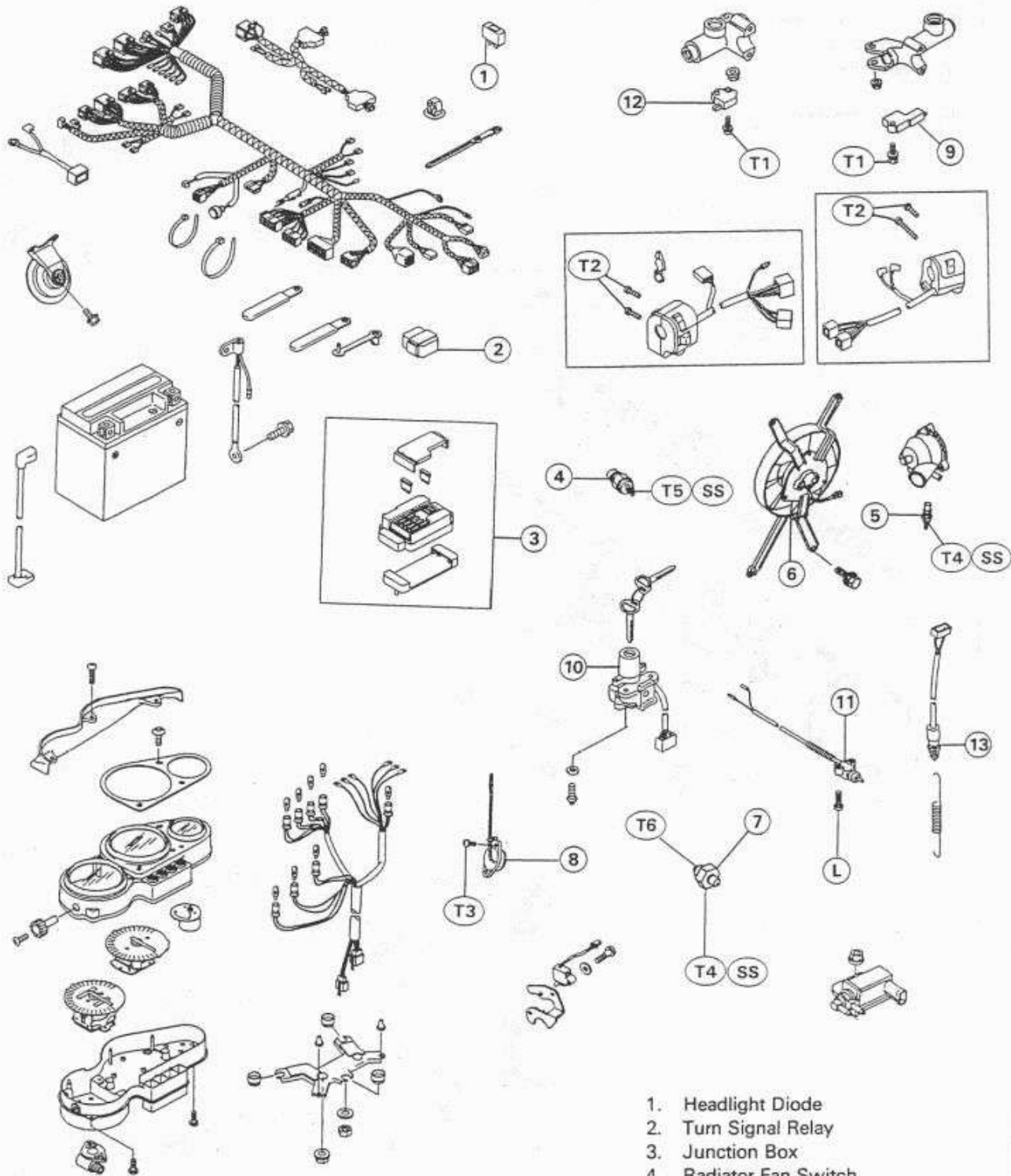

L: Apply a non-permanent locking agent.  
 SS: Apply silicone sealant.

- T1: 1.0 N-m (0.10 kg-m, 9 in-lb)
- T2: 3.4 N-m (0.35 kg-m, 30 in-lb)
- T3: 3.9 N-m (0.40 kg-m, 35 in-lb)
- T4: 15 N-m (1.5 kg-m, 11.0 ft-lb)
- T5: 18 N-m (1.8 kg-m, 13.0 ft-lb)
- T6: 1.5 N-m (0.15 kg-m, 13 in-lb)

- 1. Headlight Diode
- 2. Turn Signal Relay
- 3. Junction Box
- 4. Radiator Fan Switch
- 5. Water Temperature Sensor
- 6. Radiator Fan
- 7. Oil Pressure Switch
- 8. Neutral Switch
- 9. Front Brake Light Switch
- 10. Ignition Switch
- 11. Side Stand Switch
- 12. Starter Lockout Switch
- 13. Rear Brake Light Switch



## Specifications

Item	Standard	Service Limit
<b>Battery:</b>		
Type	MF (Maintenance Free) Battery	---
Capacity	ZX750N 12 V 8 Ah	---
	ZX750P 12 V 10 Ah	---
Voltage	ZX750N 12.8 V or more	---
	ZX750P 12.6 V or more	---
<b>Alternator (Charging System):</b>		
Type	Three-phase AC (built-in regulator/rectifier)	---
Charging voltage	14.2 ~ 14.8 V @ engine speed 4 000 r/min(rpm)	---
Rotor coil resistance	2.3 ~ 3.5 $\Omega$	---
Stator coil resistance	1.0 $\Omega$ or less	---
Slip ring diameter	14.4 mm	14.0 mm
Carbon brush length	10.5 mm	4.5 mm
<b>Ignition System:</b>		
Pickup coil air gap	0.4 ~ 0.6 mm (Non-adjustable)	---
Pickup coil resistance	375 ~ 565 $\Omega$	---
Ignition coil:		
3 needle arcing distance	7 mm or more	---
Primary winding resistance	2.3 ~ 3.5 $\Omega$	---
Secondary winding resistance	12 ~ 18 k $\Omega$	---
Spark plug:		
Type	NGK CR9E or ND U27ESR-N	---
Gap	0.7 ~ 0.8 mm	---
IC igniter resistance	in the text	---
<b>Electric Starter System:</b>		
Starter motor:		
Brush length	12 mm	8.5 mm
Commutator diameter	28 mm	27 mm
<b>Fuel Pump:</b>		
Fuel pump relay internal resistance	in the text	---
Fuel pump pressure	11 ~ 16 kPa (0.11 ~ 0.16 kg/cm <sup>2</sup> , 1.6 ~ 2.3 psi)	---
<b>Switch and Sensor:</b>		
Rear brake light switch timing	ON after about 10 mm pedal travel	---
Engine oil pressure switch connections	When engine is stopped: ON When engine is running: OFF	---
Fan switch connections		
Rising temperature	From OFF to ON @ 93 ~ 103°C (199 ~ 217°F)	---
Falling temperature	From ON to OFF @ 91 ~ 95°C (196 ~ 203°F)	---
Water temperature sensor resistance	ON: Less than 0.5 $\Omega$ OFF: More than 1 M $\Omega$ 47 ~ 57 $\Omega$ @80°C (176°F) 26 ~ 30 $\Omega$ @100°C (212°F)	---
Throttle switch connections	When grip is opened: ON When grip is closed: OFF	---

**Special Tool – Bearing Driver Set: 57001-1129**  
**Crankcase Splitting Tool Assembly: 57001-1362**  
**Hand Tester: 57001-1394**

**Owner's Tool – Spark Plug Wrench, 16mm : 92110-1154**

**Sealant – Kawasaki Bond (Silicone Sealant): 56019-120**

# 15-6 ELECTRICAL SYSTEM

## Parts Location

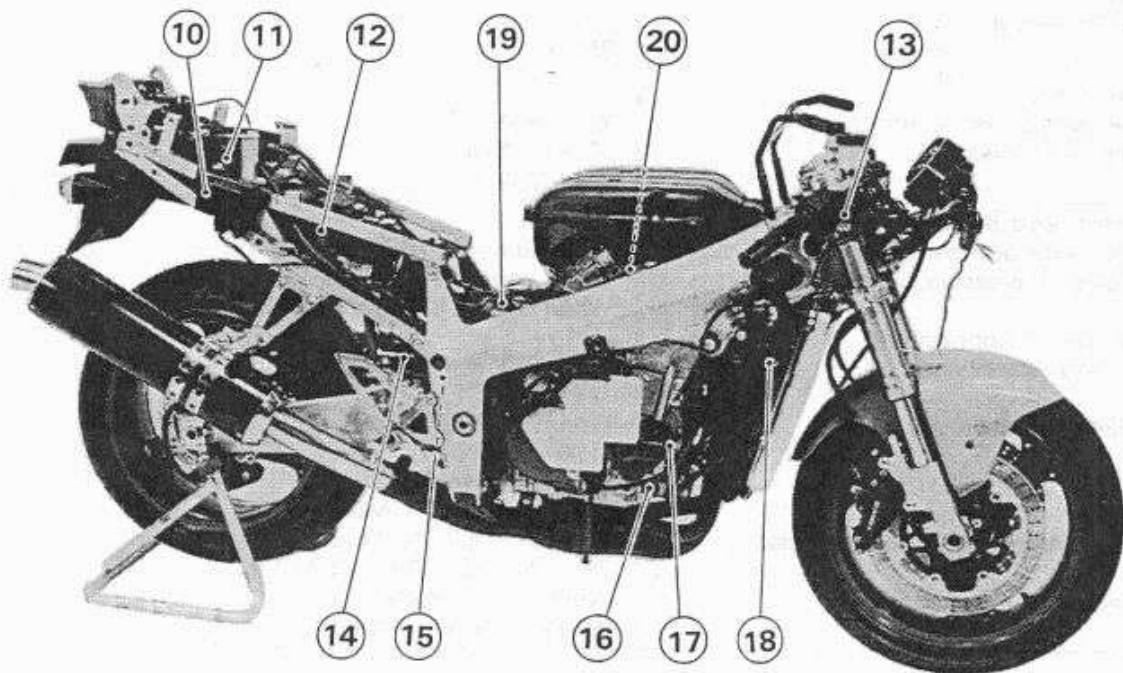
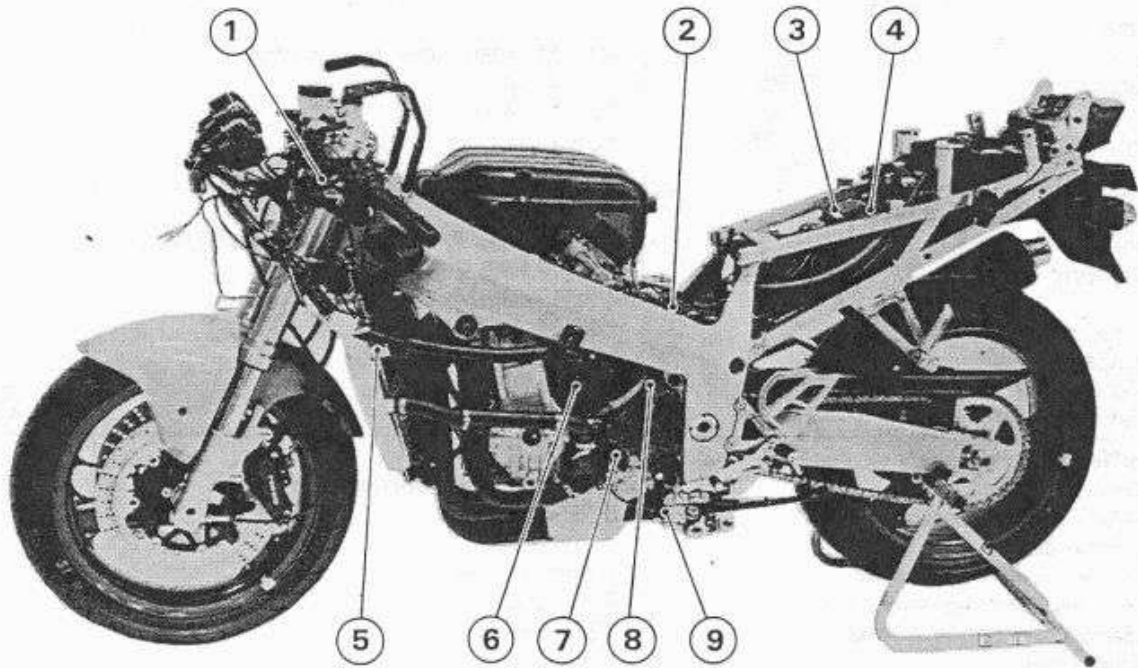

1. Starter Lockout Switch
2. Ignition Coils
3. Junction Box
4. Starter Relay and Main Fuse
5. Radiator Fan Switch
6. Alternator
7. Neutral Switch
8. Starter Motor

9. Side Stand Switch
10. IC Igniter
11. Turn Signal Relay
12. Fuel Pump Relay
13. Front Brake Light Switch
14. Rear Brake Light Switch
15. Fuel Pump
16. Oil Pressure Switch

17. Pickup Coil
18. Water Temperature Sensor
19. Fuel Enricher Solenoid Valve (ZX750N)
20. Throttle Switch (ZX750N)

## Precautions

There are a number of important precautions that are musts when servicing electrical systems. Learn and observe all the rules below.

- Do not reverse the battery lead connections. This will burn out the diodes on the electrical parts.
- Always check battery condition before condemning other parts of an electrical system. A fully charged battery is a must for conducting accurate electrical system tests.
- The electrical parts should never be struck sharply, as with a hammer, or allowed to fall on a hard surface. Such a shock to the parts can damage them.
- To prevent damage to electrical parts, do not disconnect the battery leads or any other electrical connections when the ignition switch is on, or while the engine is running.
- Because of the large amount of current, never keep the starter button pushed when the starter motor will not turn over, or the current may burn out the starter motor windings.
- Do not use a meter illumination bulb rated for other than voltage or wattage specified in the wiring diagram, as the meter or gauge panel could be warped by excessive heat radiated from the bulb.
- Take care not to short the leads that are directly connected to the battery positive (+) terminal to the chassis ground.
- Troubles may involve one or in some cases all items.  
Never replace a defective part without determining what CAUSED the failure. If the failure was caused by some other item or items, they too must be repaired or replaced, or the new replacement will soon fail again.
- Make sure all connectors in the circuit are clean and tight, and examine wires for signs of burning, fraying, etc. Poor wires and bad connections will affect electrical system operation.
- Measure coil and winding resistance when the part is cold (at room temperature).

○ Color Codes:

BK Black	G Green	P Pink
BL Blue	GY Gray	PU Purple
BR Brown	LB Light blue	R Red
CH Chocolate	LG Light green	W White
DG Dark green	O Orange	Y Yellow

○ Electrical Connectors

Female Connectors [A]

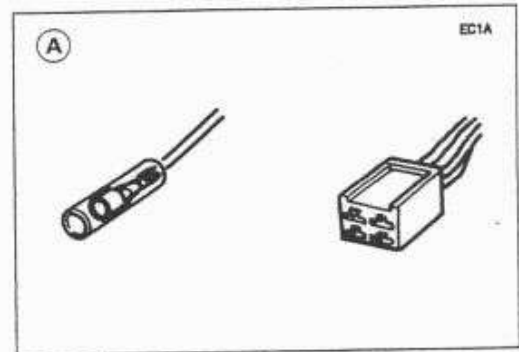

Male Connectors [B]

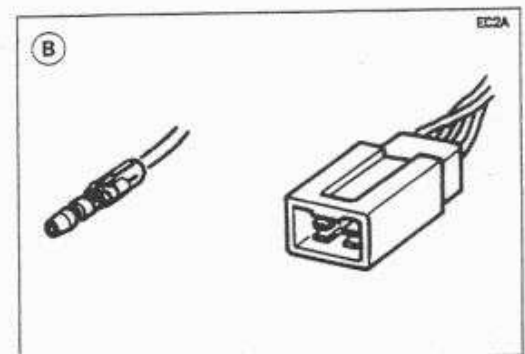

## Electrical Wiring

### Wiring Inspection

- Visually inspect the wiring for signs of burning, fraying, etc.
- ★ If any wiring is poor, replace the damaged wiring.
- Pull each connector [A] apart and inspect it for corrosion, dirt, and damage.
- ★ If the connector is corroded or dirty, clean it carefully. If it is damaged, replace it.
- Check the wiring for continuity.
- Use the wiring diagram to find the ends of the lead which is suspected of being a problem.
- Connect the hand tester between the ends of the leads.

#### Special Tool – Hand Tester: 57001-1394

- Set the tester to the x 1  $\Omega$  range, and read the tester.
- ★ If the tester does not read 0  $\Omega$ , the lead is defective. Replace the lead or the wiring harness [B] if necessary.

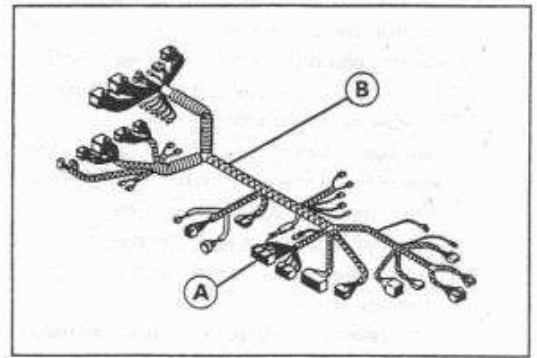

## Battery

### Charging Condition Inspection

Battery charging condition can be checked by measuring battery terminal voltage.

- Remove the seats (see Frame chapter).
- Disconnect the battery terminal leads.

#### CAUTION

Be sure to disconnect the negative terminal lead first.

- Measure the battery terminal voltage.

#### NOTE

○ Measure with a digital voltmeter [A] which can be read one decimal place voltage.

★ If the reading is below the specified, refreshing charge is required.

#### Battery Terminal Voltage

Standard: 12.8 V or more (ZX750N)  
12.6 V or more (ZX750P)

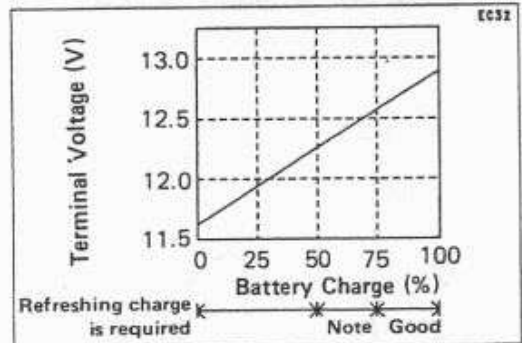
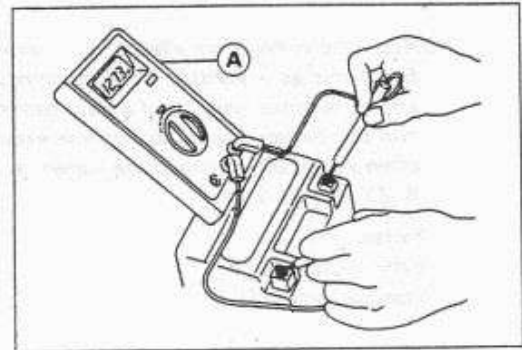

### Refreshing Charge

- Disconnect the battery terminal leads (see Charging Condition Inspection).
- Remove the battery [A].
- Refresh-charge by following method according to the battery terminal voltage.

#### CAUTION

This battery is sealed type. Never remove sealing caps [B] even at charging. Never add water. Charge with current and time as stated below.

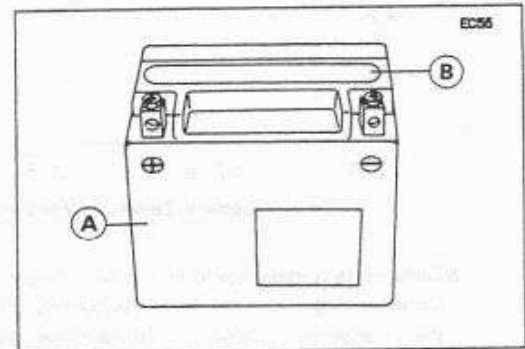

Terminal Voltage: 11.5 ~ less than 12.8 V (ZX750N), 12.6 V (ZX750P)

#### Standard Charge

ZX750N: 0.9 A x 5 ~ 10 h (see next page's chart)

ZX750P: 1.2 A x 5 ~ 10 h (see next page's chart)

#### Quick Charge

ZX750N: 4.0 A x 1 h

ZX750P: 5.0 A x 1.0 h

#### CAUTION

If possible, do not quick charge. If the quick charge is done due to unavoidable circumstances, do standard charge later on.

Terminal Voltage : less than 11.5 V

Charging Method : 0.9 A x 20 h (ZX750N)

1.2 A x 20 h (ZX750P)

**NOTE**

○ Raise the voltage initially (25 V as maximum), and charge for about 5 minutes as a yardstick. If ammeter shows no change in current after 5 minutes, you need a new battery. The current, if it can flow into the battery, tends to become excessive. Adjust the voltage as often as possible to keep the current at standard value (ZX750N: 0.9 A, ZX750P: 1.2 A).

- Battery [A]
- Battery Charger [B]
- Standard Value [C]

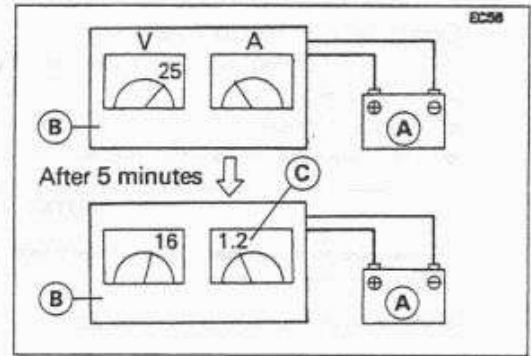

**Battery Standard Charge Time Chart**

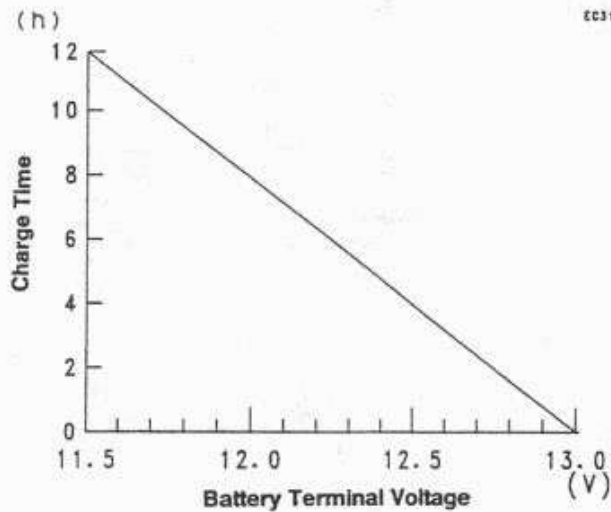

- Determine battery condition after refreshing charge.
- Determine the condition of the battery 30 minutes after completion of the charge by measuring the terminal voltage according to the table below.

Criteria	Judgement
12.8 V (N), 12.6 V (P) or higher	Good
12.0 ~ 12.8 V (N), 12.6 V (P) or lower	Charge insufficient → Recharge.
12.0 V or lower	Unserviceable → Replace

(N): ZX750N      (P): ZX750P

## Alternator

### Alternator Removal

#### NOTE

○ Do not remove the alternator to remove the rectifier, regulator, and carbon brush assembly. They can be removed after removing the alternator cover.

- Remove the following.
  - Fuel Tank (see Fuel System chapter)
  - Left Lower Fairing (see Frame chapter)
  - Alternator Lead Connector [A]
  - Water Pump Pipe and Hose
  - Clutch Slave Cylinder (see Clutch chapter)
- Remove the alternator mounting bolts [A].

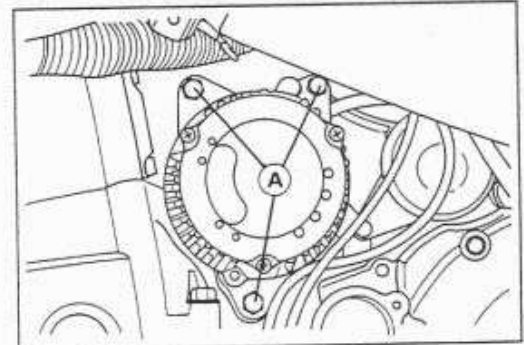
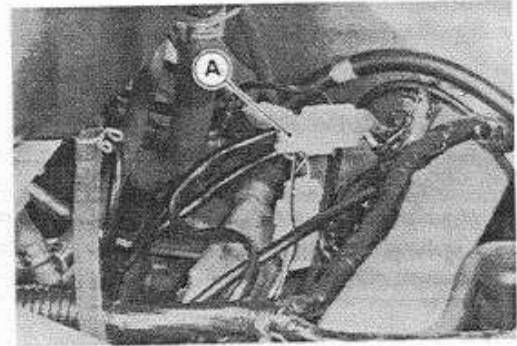

- Detach the alternator [A] from the engine and then pull out the upper right mounting bolt [B].

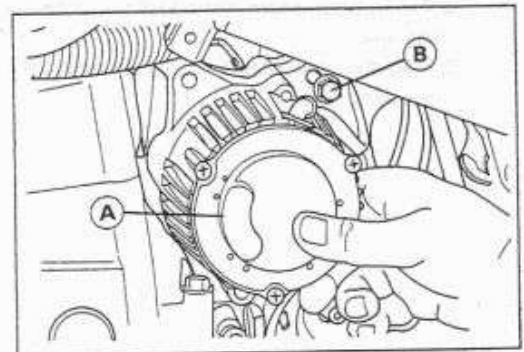

### Alternator Installation

- When installing the alternator, clean the alternator legs [A] and crankcase [B] where the alternator is grounded.
- Apply a small amount of engine oil to the O-ring [C].
- Tighten the alternator mounting bolts.
- The lower mounting bolt is shorter than the two upper mounting bolts.

**Torque – Alternator Mounting Bolts: 25 N-m(2.5 kg-m, 18.0 ft-lb)**

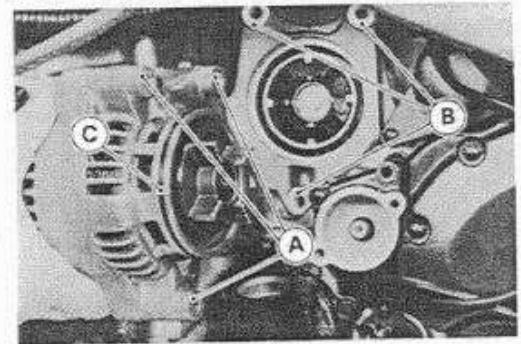

### Alternator Disassembly

- Remove:
  - Alternator (see Alternator Removal)
  - Screws [A] and Alternator Cover [B]

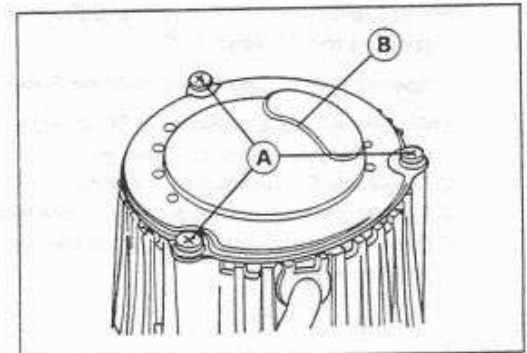

- Remove:
  - Brush Assembly [A]
  - Rectifier [B]
  - Regulator [C]
- Unsolder [D] the leads on the rectifier.

**CAUTION**

When unsoldering the alternator leads on the rectifier terminals, do it quickly. If high temperatures are applied for more than a few seconds, the rectifier's diodes may be damaged.

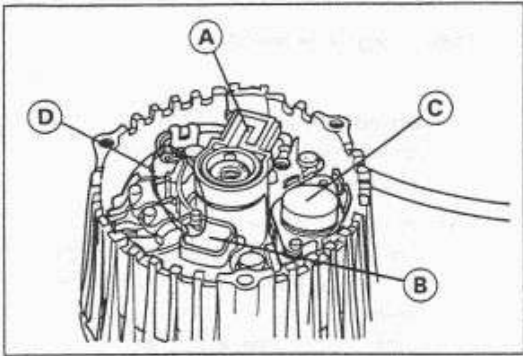

- If it is necessary to remove the carbon brush, unsolder the brush lead [A].

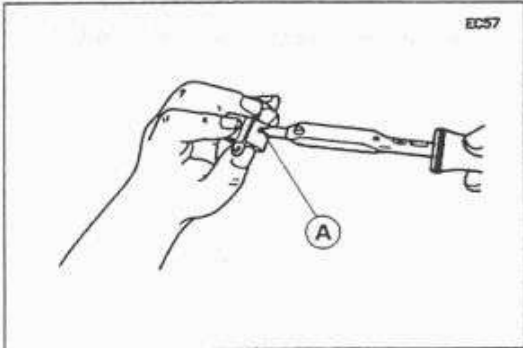

- Remove the alternator coupling to disassemble the rest of the parts as follows.
- Hold the alternator with a vise and remove the coupling nut [A] and coupling [B].

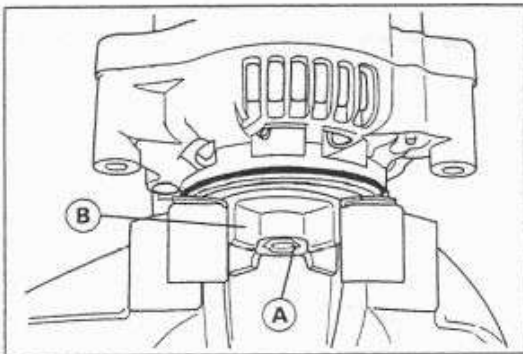

- Unscrew the alternator assembly nuts [A].
- Remove the alternator frame [B].

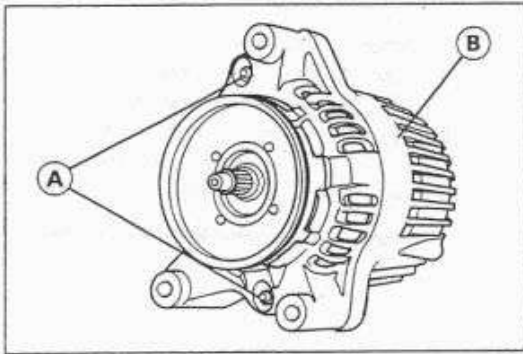

- ★ If the alternator frame [A] is difficult to remove, use the crankcase splitting tool assembly [B].

**Special Tool – Crankcase Splitting Tool Assembly: 57001-1362**

- Be sure to put a washer (O.D.12 x I.D. 6 mm)[C] on the alternator rotor [D] to prevent its damage.
- Screw the 5 mm bolts all the way.
- Tighten the center bolt on the special tool to split the alternator halves.
- Once the alternator is split, remove the special tool, and remove the alternator frame.

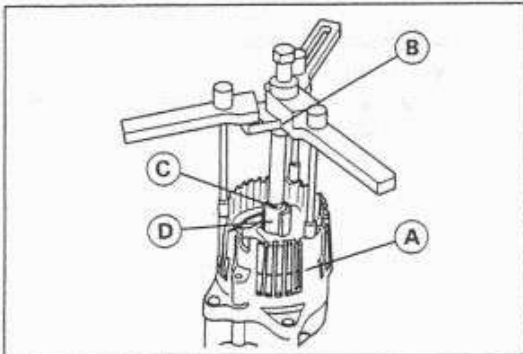



- To remove the frame ball bearing [A] from the alternator rotor [B], use a suitable bearing puller [C].
- Discard the frame ball bearing.

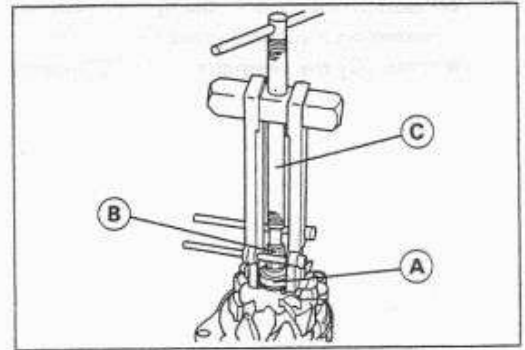

- Press out the alternator rotor [A] from the alternator housing [B].

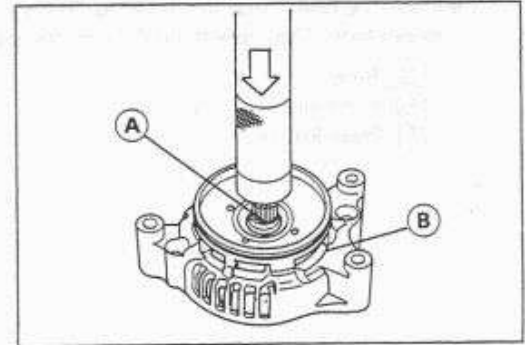

- Remove:
  - Screws [A] and Bearing Retainer [B]
  - Housing Bearing [C]
  - Bearing Holder
- Remove the oil seal using the bearing driver set.
  - Special Tool – Bearing Driver Set: 57001-1129**
- Discard the housing bearing and oil seal.

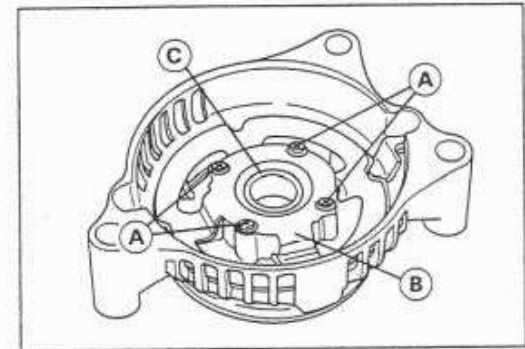

#### Alternator Assembly

- Install the oil seal [A] using the bearing driver set.
  - Special Tool – Bearing Driver Set: 57001-1129**
- Install:
  - Bearing Holder [B]
  - Housing Bearing [C]

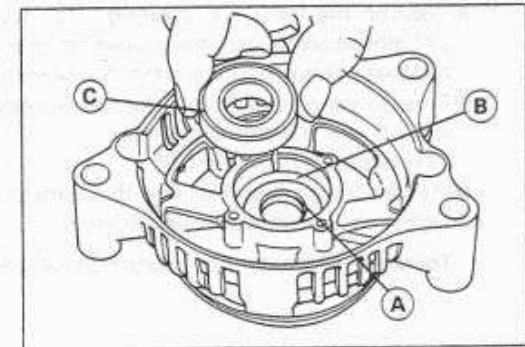

- Install the bearing retainer with its mounting screws.

**Torque – Alternator Bearing Retainer Screws: 2.5 N-m (0.25 kg-m, 22 in-lb)**

- Position the new housing ball bearing [A] so that the inner race is seated on a suitable press fixture [B].
- Press [C] the alternator rotor [D] into the housing ball bearing.

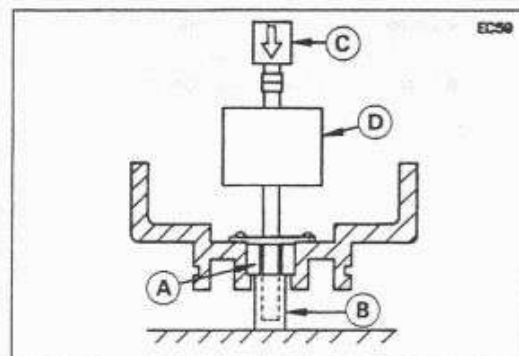

- Press the new frame ball bearing [A] and bearing covers [B] onto the rotor shaft. The wide band [C] on the outer race goes up.

- [D] Ring
- [E] Alternator Housing
- [F] Press Fixture

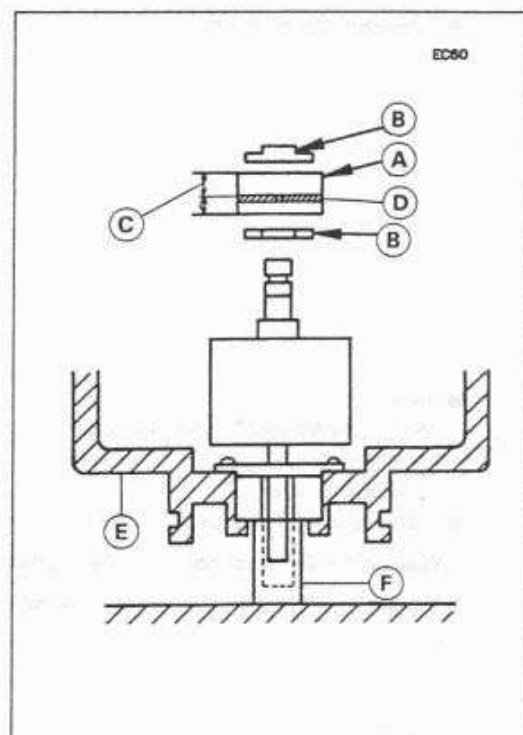

- Position the frame ball bearing ring [A] so that the ring projection [B] almost aligns with the groove chamfer [C] where the groove is the deepest. This makes alternator frame installation easier.

- Press in the oil seal so that the spring band faces out and the seal end is flush with the end of the hole.

Eccentric Ring Groove [D]

- Install the alternator frame on the alternator rotor.

- Tighten the alternator assembly nuts.

**Torque – Alternator Assembly Nuts: 4.4 N-m (0.45 kg-m, 39 in-lb)**

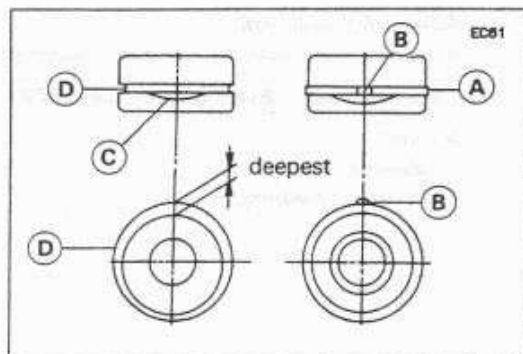

- Solder the carbon brush lead [A] with the brush holder as shown.

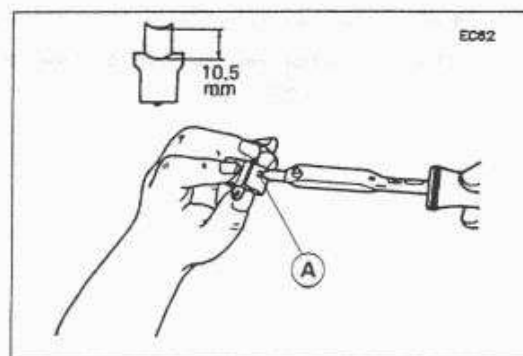

- Run the alternator leads [A] into the grooves [B] as shown.

**CAUTION**

When soldering the alternator leads to the rectifier terminals, do it quickly. If high temperatures are applied for more than a few seconds, the rectifier's diodes may be damaged.

**Torque – Alternator Regulator Screws, Alternator Brush Screws, and Alternator Lead Terminal Screws: 3.4 N-m (0.35 kg-m, 30 in-lb)**

- Fit the projection [A] of the alternator cover in the alternator frame groove [B].

**Torque – Alternator Cover Screws: 3.4 N-m (0.35 kg-m, 30 in-lb)  
Alternator Coupling Nut: 54 N-m (5.5 kg-m, 40 ft-lb)**

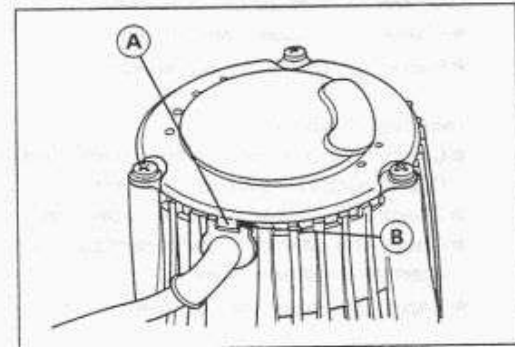
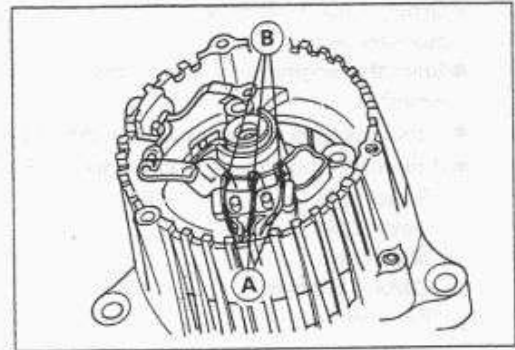
**Operational Inspection**

For any charging system problems, always check the charging system wiring first (see Wiring Inspection), and then check the system with the following tests shown in the troubleshooting guide.

**Troubleshooting Guide**

Test No.	Trouble	Symptoms
1	Battery discharged	Starter not rotating
2	Battery overcharged	Electrolyte level lowering quickly
3	Noise	Alternator or alternator chain noise

**Test No. 1-Battery Discharged**

- Remove:
  - Left Lower Fairing (see Frame chapter)
- Remove the screws holding the alternator cover [A], and take off the cover.
- Check that the alternator leads and connectors are in good condition.
- ★ If not, repair or replace the damaged parts.
- Replace the discharged battery with a good battery.

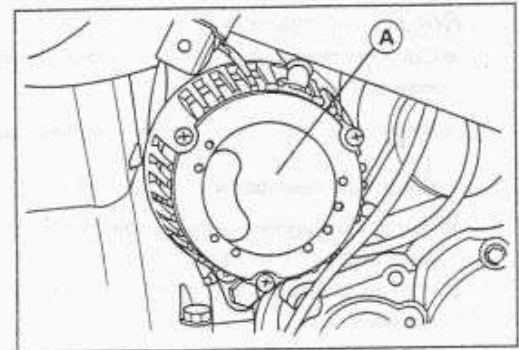

- Connect the hand tester [A] to the battery leads as shown.
- Check charging voltage with the engine running.
- ★ If the charging voltage is higher than 13.5 V, the charging system is in good condition.
- ★ If the charging voltage is lower than 13.5 V, check the following.

**Charging Voltage 14.2 ~ 14.8 V @engine speed 4000 r/min(rpm)**

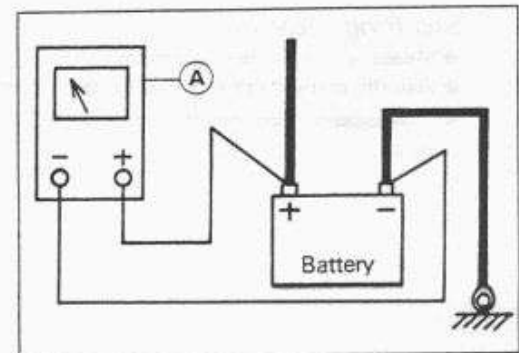

- Ground the F terminal [A] of the regulator to the engine with an auxiliary wire.
- Start the engine, and check the charging voltage with the engine running.
- ★ If the charging voltage is higher than 13.5 V, check the regulator.
- ★ If the charging voltage is lower than 13.5 V, check the following.
  - Stator Coil
  - Rotor Coil
  - Slip Rings
  - Carbon Brushes
  - Rectifier

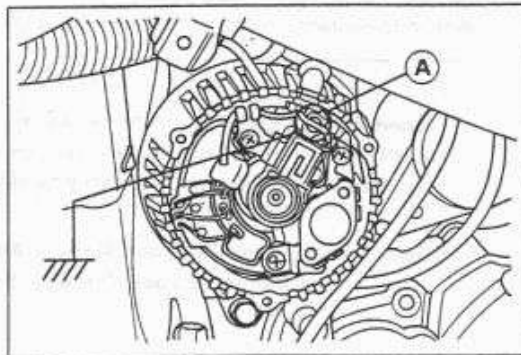

### Test No. 2-Battery Overcharged

- Check the regulator and/or rotor.
- ★ Repair or replace the damaged parts.

### Test No. 3-Noise

- Check the alternator chain slack and adjust it if necessary (see Crankshaft/Transmission chapter).
- Check the alternator shaft ball bearings.
- Check the alternator ball bearings, stator coil, and/or rectifier if the alternator makes a noise.
- ★ Repair or replace the damaged parts.

### Stator Coil Inspection

- Connect the hand tester ( $\times 1 \Omega$  range) between the coil leads and read the tester.
- ★ If the tester does not read as specified, replace the alternator frame.

#### Stator Coil Resistance : $1.0 \Omega$ or less

- Using the highest hand tester range, measure the resistance between the stator coil core and each of the coil windings.
- ★ If there is any reading at all, the stator coil winding has a short and the alternator frame must be replaced.

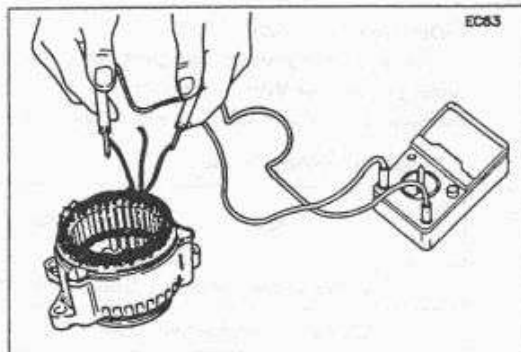

### Rotor Coil Inspection

- Connect the hand tester ( $\times 1 \Omega$  range) between the slip rings [A] and read the tester.
- ★ If the tester does not read as specified, replace the rotor [B].

#### Rotor Coil Resistance: $2.3 \sim 3.5 \Omega$

- Using the highest tester range, measure the resistance between the rotor shaft [C] and each of the slip rings.
- ★ If there is any reading at all, the rotor coil has a short and must be replaced.

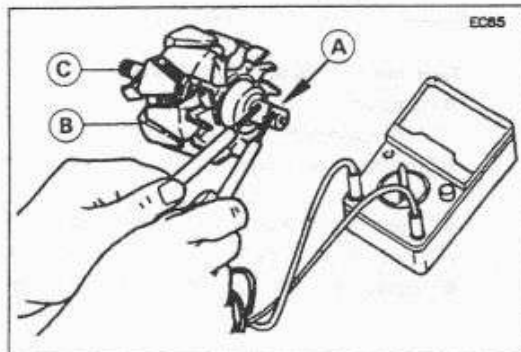

### Slip Ring Cleaning

- Measure the slip ring diameter.
- Visually inspect the slip ring for dirt or pitting.
- ★ If necessary, smooth the slip ring with No. 300 ~ No. 500 emery cloth.

### Slip Ring Diameter

- Measure the slip ring diameter.
- ★ If the measurement is less than the service limit, replace the rotor [A].

#### Slip Ring Diameter

Standard: 14.4 mm  
Service Limit: 14.0 mm

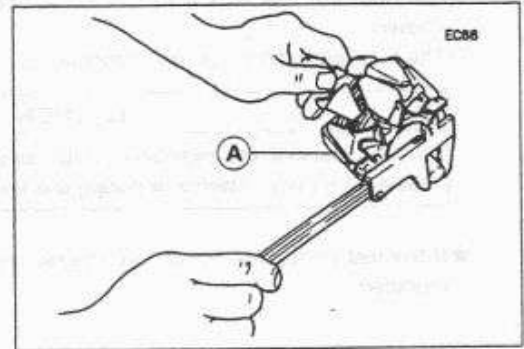

### Carbon Brush Length

- Measure the length [A] of both carbon brushes that stick out of the holder.
- ★ If either one is worn down to less than the service limit, replace it.

#### Carbon Brush Length (projected portion)

Standard: 10.5 mm  
Service Limit: 4.5 mm

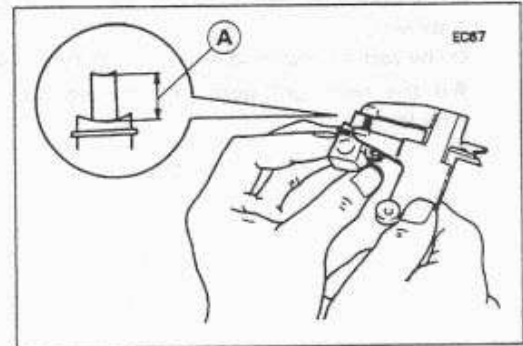

### Rectifier Inspection

- Set the hand tester to the 1 k $\Omega$  range.
- Zero the hand tester, and connect it to each terminal [A] to check the resistance in both directions.
- The resistance should be low in one direction and more than ten times as much in the other direction. If the rectifier [B] shows low or high in both directions, the rectifier is defective and the rectifier must be replaced.

#### NOTE

- The actual meter reading varies with the meter used and the individual rectifier, but, generally speaking, the lower reading should be from zero to one half the scale.

#### CAUTION

If a megger or a meter with a large-capacity battery is used, the rectifier will be damaged.

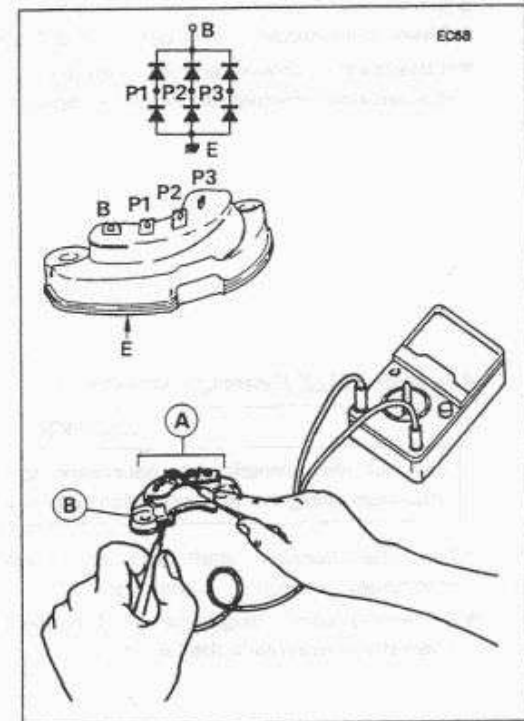

### Regulator Inspection

- Prepare testing tools.
  - Test light: Bulb rated 12 V 3.4 W
  - Batteries: Two 12 V batteries
  - Test wires: Three auxiliary wires

#### CAUTION

The test light works as an indicator and also a current limiter to protect the regulator from excessive current. Do not use an ammeter instead of a test light.

- Connect the test light and the 12 V battery to the regulator [A] as shown.
- The test light should go on at this time.

**CAUTION**

Do not contact the regulator metal case with the wires from the battery (+) or (-) terminal during the test.

- ★ If the test light does not go on, the regulator is damaged and must be replaced.

- Connect the test light and two 12 V batteries to the regulator as shown.
- The test light should not go on at this time.

- ★ If the test light goes on, the regulator is damaged and must be replaced.

- Set the hand tester (special tool) to the 1 k $\Omega$  range.
- Check the resistance between IG and F terminals in both directions.
- ★ If the reading shows zero or infinity (no reading) in both directions, the regulator is defective and must be replaced.

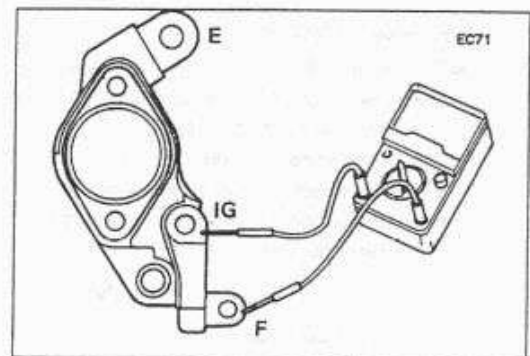
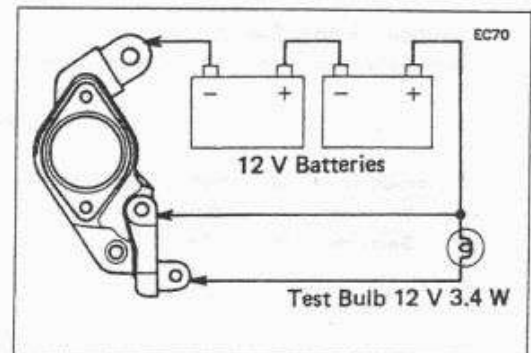
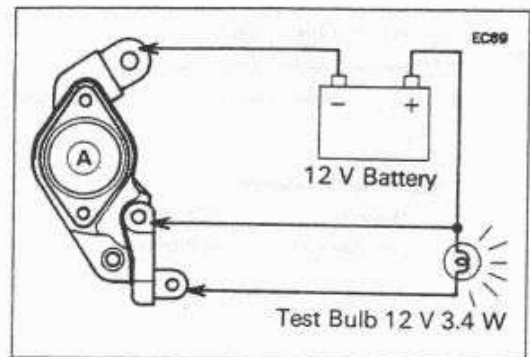

### Alternator Ball Bearing Inspection

**CAUTION**

Do not disassemble the alternator for bearing inspection since disassembling the alternator damages the bearings.

- Turn the alternator shaft back and forth while checking for plays, roughness or binding of bearings.
- ★ If bearing play, roughness, or binding is found, disassemble the alternator and replace the bearings.

Alternator Circuit

EC102

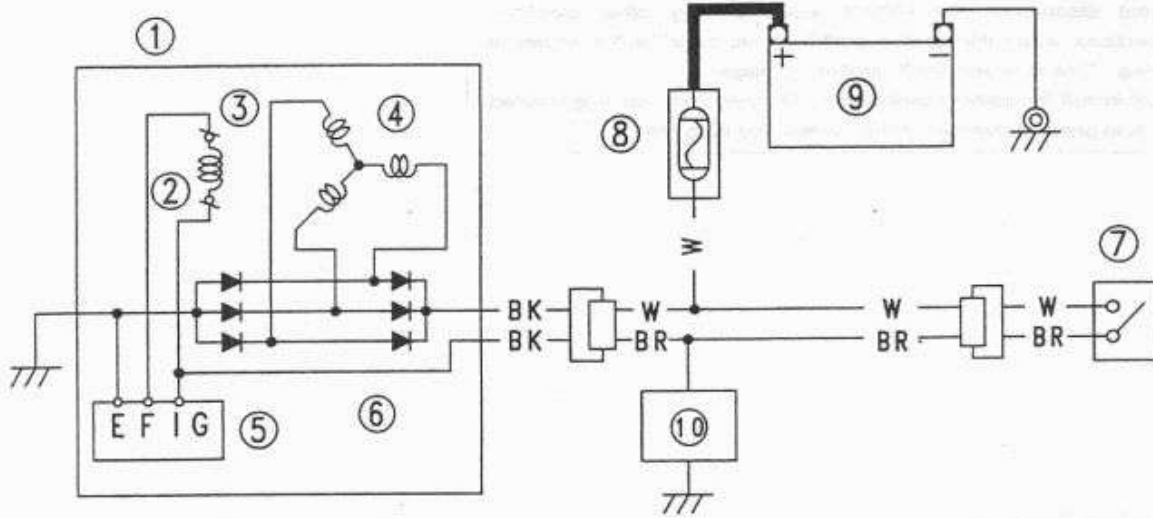

- 1. Alternator
- 2. Rotor
- 3. Carbon Brush
- 4. Stator Coil

- 5. Regulator
- 6. Rectifier
- 7. Ignition Switch
- 8. Main Fuse 30A

- 9. Battery
- 10. Load

## Ignition System

**⚠ WARNING**

The ignition system produces extremely high voltage. Do not touch the spark plugs, ignition coils, or spark plug leads while the engine is running, or you could receive a severe electrical shock.

**CAUTION**

Do not disconnect the battery leads or any other electrical connections when the ignition switch is on, or while the engine is running. This is to prevent IC igniter damage.  
Do not install the battery backwards. The negative side is grounded. This is to prevent damage to the diodes and IC igniter.

*Pickup Coil Removal*

## ● Remove:

- Fuel Tank (see Fuel System chapter)
- Pickup Coil Lead Connector [A]
- Right Lower Fairing (see Frame chapter)
- Pickup Coil Cover [B]
- Oil Pressure Switch Lead Connector [C]

- Pickup Coil Bolts [A]
- Grommet [B]
- Pickup Coil [C]

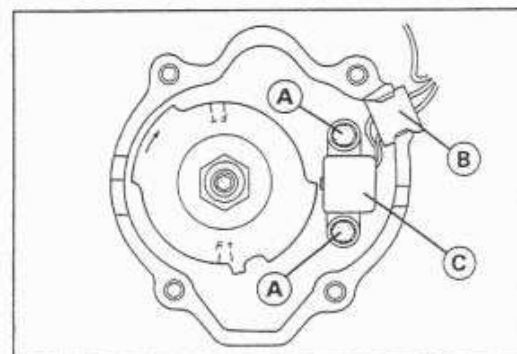
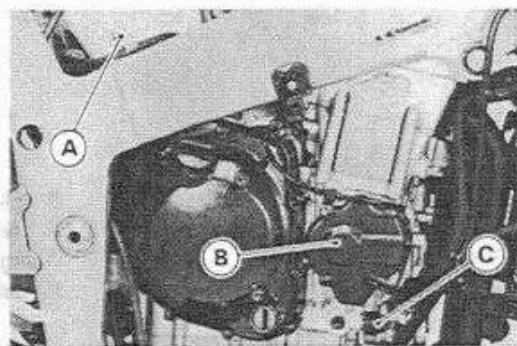
*Pickup Coil Installation*

- Route the pickup coil lead correctly (see Cable, Wire, and Hose Routing in General Information chapter).
- Install the pickup coil and tighten the pickup coil bolts.

**Torque – Pickup Coil Bolts: 7.8 N-m (0.80 kg-m, 69 in-lb)**

- Apply silicone sealant [A] to the crankcase halves mating surface on the front and rear sides of the pickup coil cover mount.

**Sealant – Kawasaki Bond (Silicone Sealant): 56019-120**

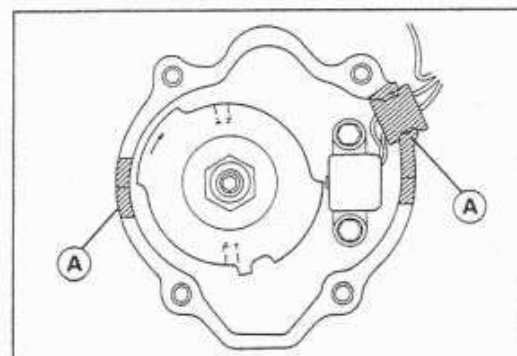



- Apply a non-permanent locking agent to the pickup coil cover bolts [A] and tighten them.

**Torque – Pickup Coil Cover Bolts: 9.8 N-m (1.0 kg-m, 87 in-lb)**

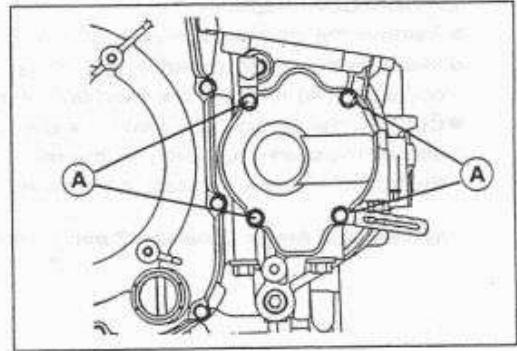

### Pickup Coil Inspection

- Remove the following.
  - Fuel Tank (see Fuel System chapter)
  - Pickup Coil Lead Connector [A]
- Set the hand tester to the x 100  $\Omega$  range and connect it to the black and yellow leads in the connector.
- ★ If there is more resistance than the specified value, the coil has an open lead and must be replaced. Much less than this resistance means the coil is shorted, and must be replaced.

**Pickup Coil Resistance: 375 ~ 565  $\Omega$**

- Using the highest resistance range of the tester, measure the resistance between the pickup coil leads and chassis ground.
- ★ Any tester reading less than infinity ( $\infty$ ) indicates a short, necessitating replacement of the pickup coil assembly.

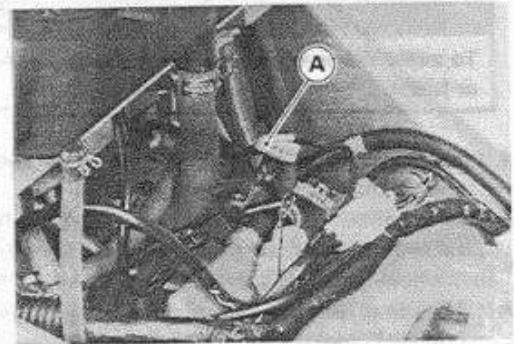

### Ignition Coil Removal

- Remove:
  - Air Cleaner Housing (see Fuel System chapter)
  - Spark Plug Caps
  - Bolt [A] and Bracket [B]
  - Primary Lead Connectors
  - Nuts and Ignition Coils [C]

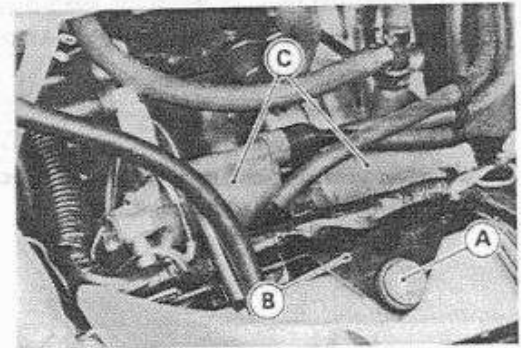

### Ignition Coil Installation

- Install:
  - #1, #4 Ignition Coil [A]
  - #2, #3 Ignition Coil [B]
  - Collars [C], Washer [D] and Nuts [E]
  - Bracket and Damper [F]
  - Bracket Mounting Bolt
- Connect the primary leads to the ignition coil terminals.
  - Black Lead → to #1, #4 Coil
  - Green Lead → to #2, #3 Coil
  - Red Leads → to both Coils

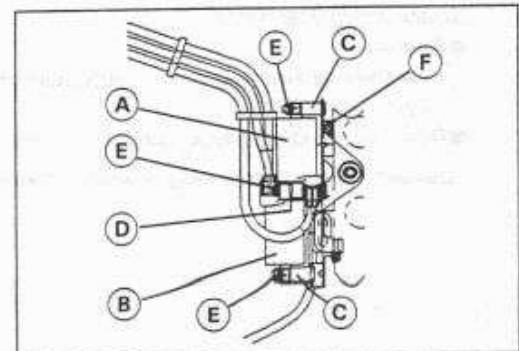

### Ignition Coil Inspection

- Remove the ignition coils (see Ignition Coil Removal).
- Measure the arcing distance with the suitable commercially available coil tester [A] to check the condition of the ignition coil [B].
- Connect the ignition coil (with the spark plug cap left attached at the end of the spark plug lead) to the tester in the manner prescribed by the manufacturer and measure the arcing distance.

**Ignition Coil Arcing Distance : 7 mm or more**

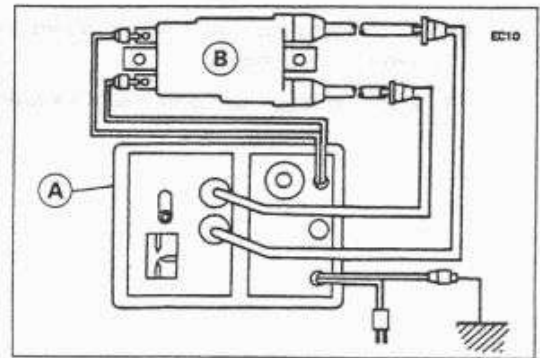

#### ⚠ WARNING

To avoid extremely high voltage shocks, do not touch the coil body or leads.

- ★ If the distance reading is less than the specified value, the ignition coil or spark plug caps are defective.
- To determine which part is defective, measure the arcing distance again with the spark plug caps removed from the ignition coil. Remove the caps by turning them counterclockwise.
- ★ If the arcing distance is subnormal as before, the trouble is with the ignition coil itself. If the arcing distance is now normal, the trouble is with the spark plug cap.
- ★ If the coil tester is not available, the coil can be checked for a broken or badly shorted winding with the hand tester.

#### NOTE

○ The hand tester cannot detect layer shorts and shorts resulting from insulation breakdown under high voltage.

- Measure the primary winding resistance [A] as follows.
  - Connect the hand tester between the coil terminals.
  - Set the tester to the x 1  $\Omega$  range, and read the tester.
- Measure the secondary winding resistance [B] as follows.
  - Remove the plug caps by turning them counterclockwise.
  - Connect the tester between the spark plug leads.
  - Set the tester to the x 1 k $\Omega$  range and read the tester.

#### Ignition Coil Winding Resistance

Primary Windings:	2.3 ~ 3.5 $\Omega$
Secondary Windings:	12 ~ 18 k $\Omega$

- ★ If the tester does not read as specified, replace the coil.
- To install the plug cap, turn it clockwise.

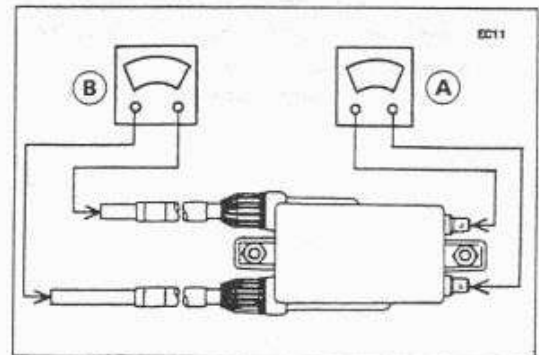

### Spark Plug Removal

- Remove:
  - Air Cleaner Housing (see Fuel System chapter)
  - Spark Plug Caps
- Remove the spark plugs using the 16 mm plug wrench.

**Owner's Tool – Spark Plug Wrench, 16 mm: 92110-1154**

### Spark Plug Installation

- Insert the spark plug vertically into the plug hole with the plug installed in the plug wrench [A].

**Owner's Tool – Spark Plug Wrench, 16 mm: 92110-1154**

- Tighten the plugs.

**Torque – Spark Plugs: 13 N-m (1.3 kg-m, 113 in-lb)**

- Fit the plug caps securely.

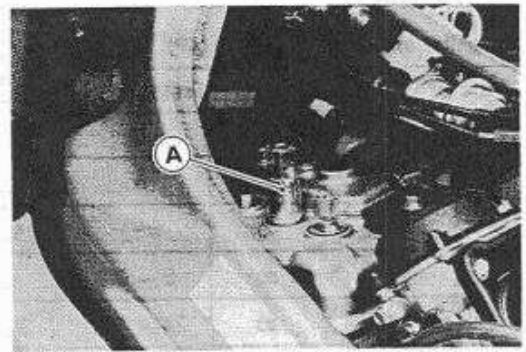

### Spark Plug Gap Inspection

- Measure the gaps [A] with a wire-type thickness gauge.
- ★ If the gaps are incorrect, carefully bend the side electrode [B] with a suitable tool to obtain the correct gaps.

**Spark Plug Gap : 0.7 ~ 0.8 mm**

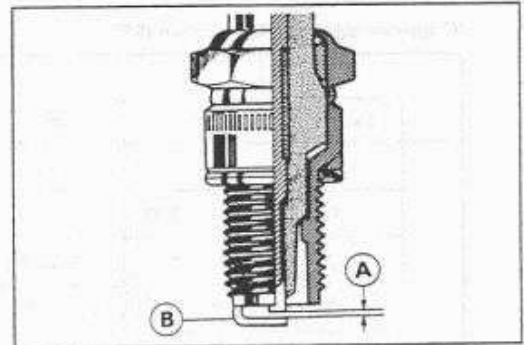

### IC Igniter Inspection

#### CAUTION

When inspecting the IC igniter, observe the following to avoid damage to the IC igniter.  
 Do not disconnect the IC igniter with the ignition switch on. This may damage the IC igniter.  
 Do not disconnect the battery leads while the engine is running. This may damage the IC igniter.

- Remove the side covers (see Frame chapter).
- Remove the IC igniter [A] and disconnect the connectors.
- Set the hand tester to the x 1 kΩ range and make the measurements shown in the table.

**Special Tool – Hand Tester: 57001-1394**

- ★ If the tester readings are not as specified, replace the IC igniter.

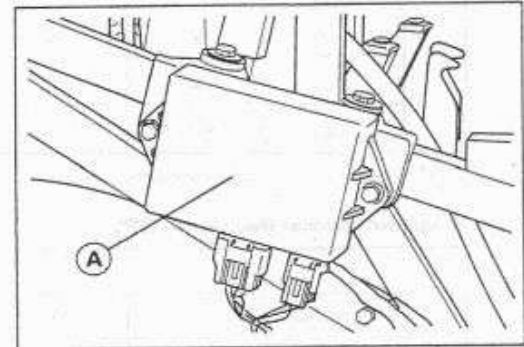

#### CAUTION

Use only Hand Tester 57001-1394 for this test. A tester other than the Kawasaki Hand Tester may show different readings.  
 If a megger or a meter with a large-capacity battery is used, the IC igniter will be damaged.

ZX750N:

**IC Igniter Internal Resistance (4P)**

Unit: kΩ

		Tester (+) Lead Connection			
Terminal		1	2	3	4
(-)*	1	-	∞	∞	∞
	2	∞	-	0 ~ 0.8	26 ~ 150
	3	∞	0 ~ 0.8	-	26 ~ 150
	4	∞	24 ~ 150	24 ~ 150	-

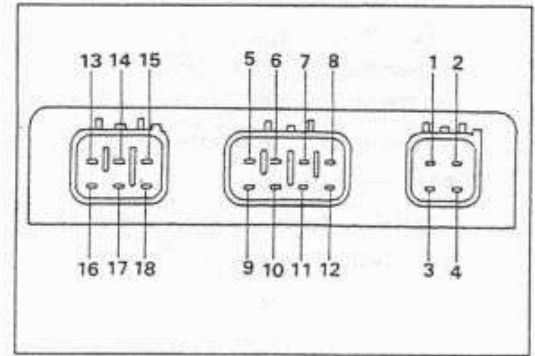

(-)\*: Tester (-) Lead Connection

**IC Igniter Internal Resistance (8P)**

Unit: kΩ

		Tester (+) Lead Connection							
Terminal		5	6	7	8	9	10	11	12
(-)*	5	-	∞	∞	∞	∞	∞	∞	∞
	6	35 ~ 300	-	22 ~ 90	20 ~ 80	35 ~ 300	45 ~ 400	∞	17 ~ 70
	7	7 ~ 30	7.5 ~ 30	-	2 ~ 8	7 ~ 30	5.5 ~ 24	∞	4 ~ 16
	8	4.2 ~ 17	4.6 ~ 19	1.8 ~ 7.5	-	4.2 ~ 17	2.8 ~ 12	∞	2 ~ 8
	9	∞	∞	∞	∞	-	∞	∞	∞
	10	∞	∞	∞	∞	∞	-	∞	∞
	11	∞	∞	∞	∞	∞	∞	-	∞
	12	1.4 ~ 6	1.6 ~ 7	2 ~ 9	1.6 ~ 6.5	1.4 ~ 6	5 ~ 22	∞	-

(-)\*: Tester (-) Lead Connection

**IC Igniter Internal Resistance (6P)**

Unit: kΩ

		Tester (+) Lead Connection					
Terminal		13	14	15	16	17	18
(-)*	13	-	∞	∞	∞	∞	∞
	14	∞	-	∞	∞	∞	∞
	15	∞	∞	-	∞	∞	∞
	16	8.5 ~ 35	∞	∞	-	∞	∞
	17	∞	∞	∞	∞	-	∞
	18	∞	∞	∞	∞	∞	-

(-)\*: Tester (-) Lead Connection

ZX750P:

## IC Igniter Internal Resistance (4P)

Unit: k $\Omega$ 

		Tester (+) Lead Connection			
Terminal		1	2	3	4
(-)*	1	-	$\infty$	$\infty$	$\infty$
	2	$\infty$	-	0 ~ 0.8	30 ~ 150
	3	$\infty$	0 ~ 0.8	-	30 ~ 150
	4	$\infty$	24 ~ 150	24 ~ 150	-

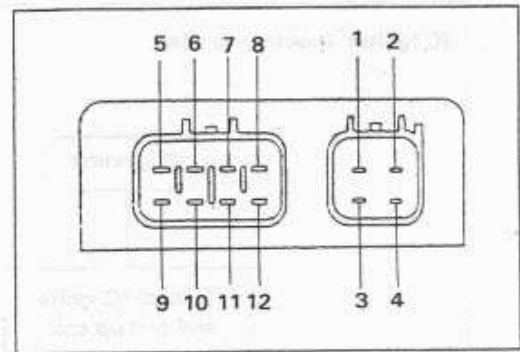

(-)\*: Tester (-) Lead Connection

## IC Igniter Internal Resistance (8P)

Unit: k $\Omega$ 

		Tester (+) Lead Connection							
Terminal		5	6	7	8	9	10	11	12
(-)*	5	-	$\infty$	$\infty$	$\infty$	$\infty$	$\infty$	$\infty$	$\infty$
	6	35 ~ 200	-	22 ~ 100	20 ~ 80	35 ~ 200	45 ~ 400	$\infty$	17 ~ 70
	7	7 ~ 28	7.5 ~ 35	-	2 ~ 8	7 ~ 28	5.5 ~ 24	$\infty$	4 ~ 16
	8	4 ~ 17	4.4 ~ 18	1.8 ~ 7.5	-	4.2 ~ 17	2.8 ~ 12	$\infty$	2 ~ 8
	9	$\infty$	$\infty$	$\infty$	$\infty$	-	$\infty$	$\infty$	$\infty$
	10	$\infty$	$\infty$	$\infty$	$\infty$	$\infty$	-	$\infty$	$\infty$
	11	$\infty$	$\infty$	$\infty$	$\infty$	$\infty$	$\infty$	-	$\infty$
	12	1.4 ~ 6	1.6 ~ 7	2.2 ~ 9	1.4 ~ 6.5	1.4 ~ 6	5 ~ 22	$\infty$	-

(-)\*: Tester (-) Lead Connection

IC Igniter Troubleshooting

- 1) IC igniter or pickup coil damaged
- 2) Even if the preceding checks show good, it may be defective in some manner not readily detectable with the hand tester.

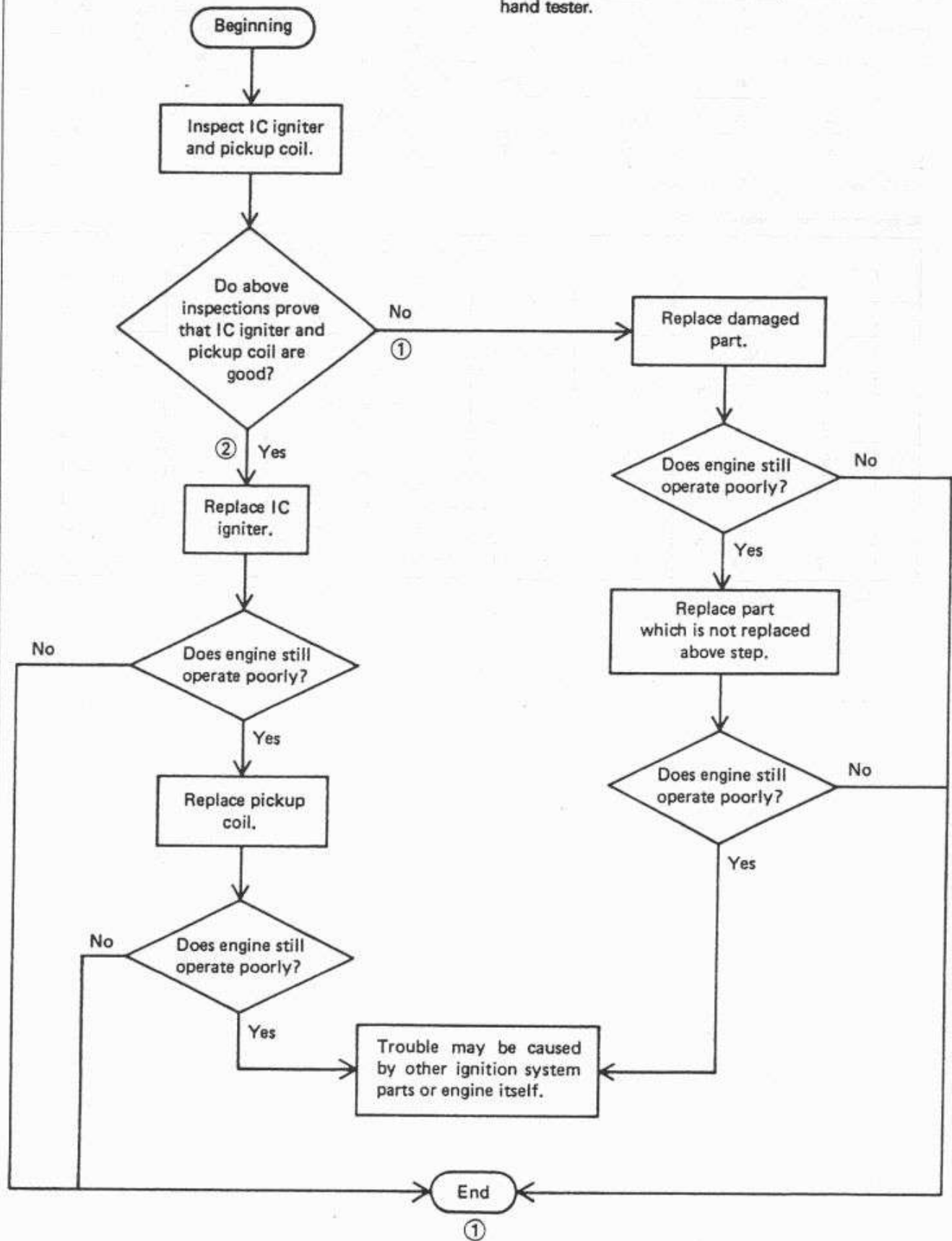

Ignition System Circuit

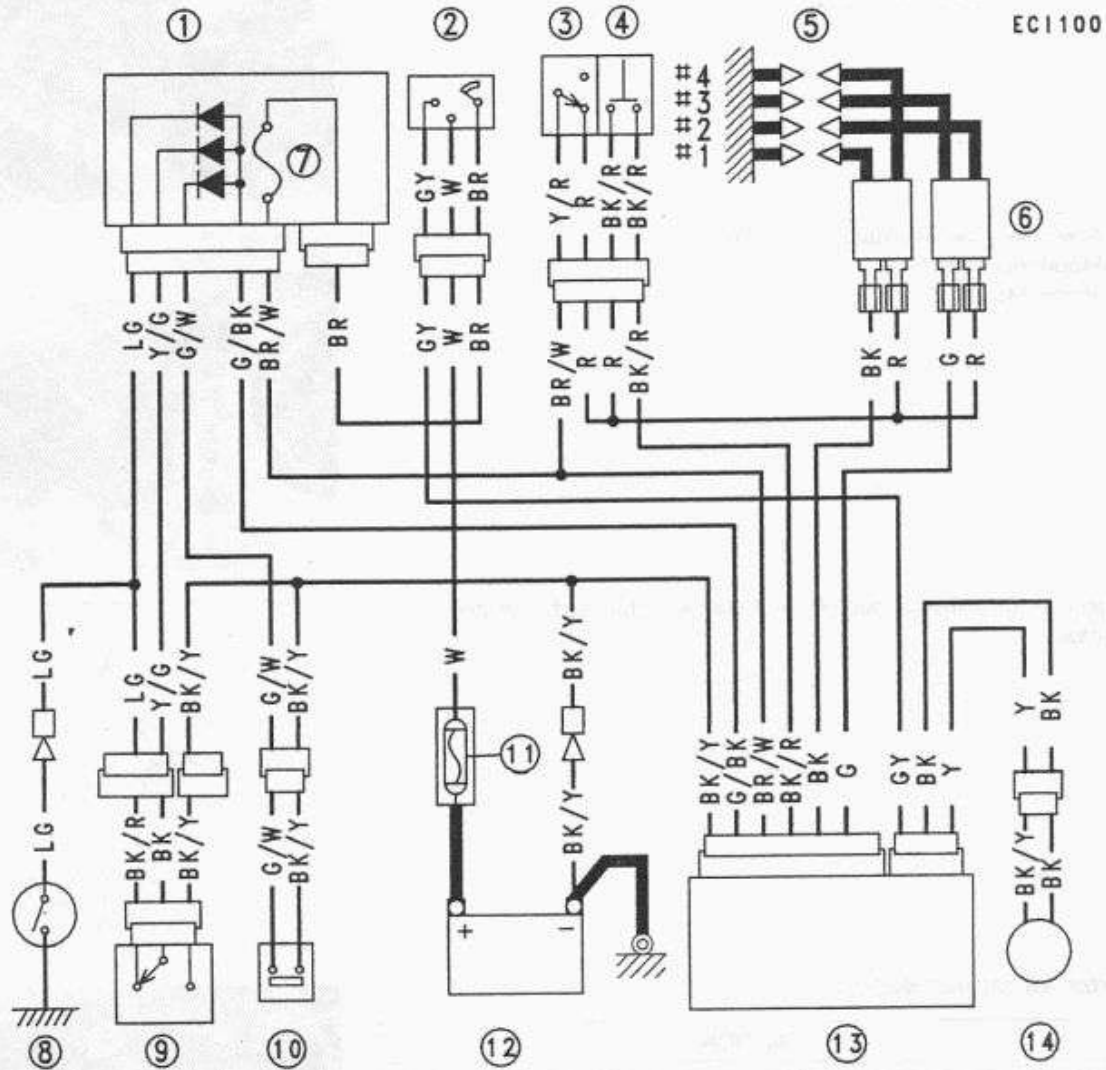

- |                       |                           |                   |
|-----------------------|---------------------------|-------------------|
| 1. Junction Box       | 6. Ignition Coils         | 11. Main Fuse 30A |
| 2. Ignition Switch    | 7. Ignition Fuse 10A      | 12. Battery       |
| 3. Engine Stop Switch | 8. Neutral Switch         | 13. IC Igniter    |
| 4. Starter Button     | 9. Starter Lockout Switch | 14. Pickup Coil   |
| 5. Spark Plugs        | 10. Side Stand Switch     |                   |

**Starter Motor**

*Starter Motor Removal*

● Remove:

- Left Lower Fairing (see Frame chapter)
- Fuel Tank (see Fuel System chapter)
- Bolt [A] and Starter Motor Lead [B]

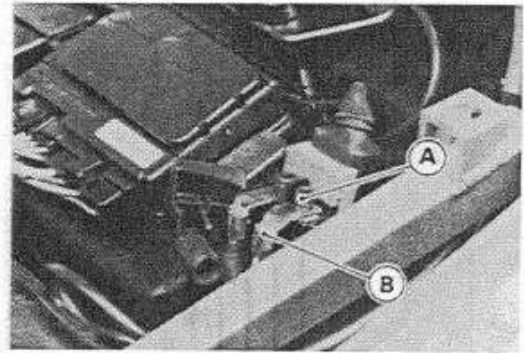

Alternator (see Alternator Removal)  
 Mounting Bolts [A]  
 Starter Motor [B]

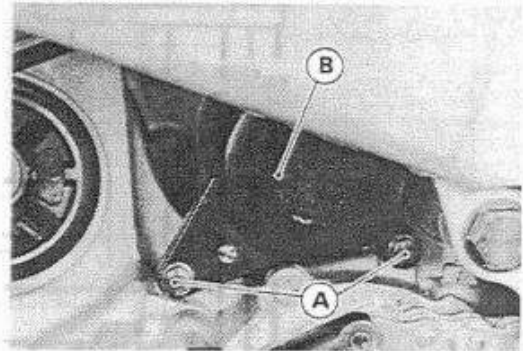

- Remove the terminal nut [A] and starter motor lead from the starter motor.

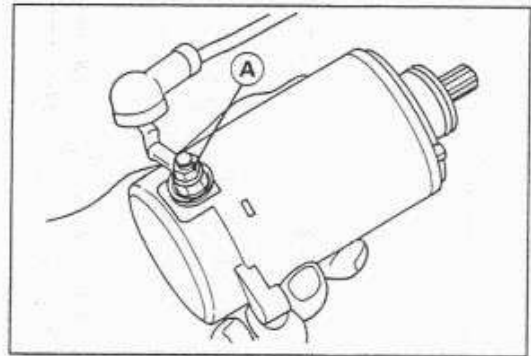

*Starter Motor Installation*

**CAUTION**

Do not tap the starter motor shaft or body. Tapping the shaft or body could damage the motor.

- When installing the starter motor, clean the starter motor legs [A] and crankcase [B] where the starter motor is grounded.

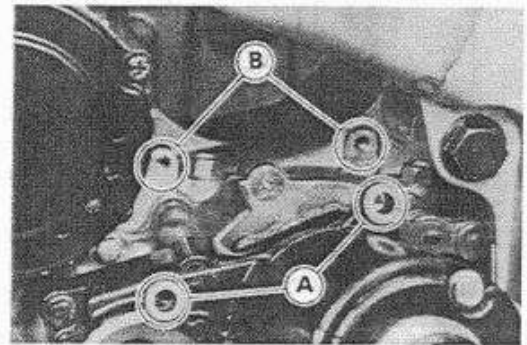

- Apply a small amount of engine oil to the O-ring [A].
  - Apply a non-permanent locking agent to the mounting bolt.
- Torque – Starter Motor Mounting Bolts: 9.8 N-m (1.0 kg-m, 87 in-lb)**  
**Starter Motor Terminal Nut: 4.9 N-m (0.50 kg-m, 43 in-lb)**

- After installation, bend the starter motor lead terminal down (see Cable, Wire, and Hose Routing in General Information chapter).

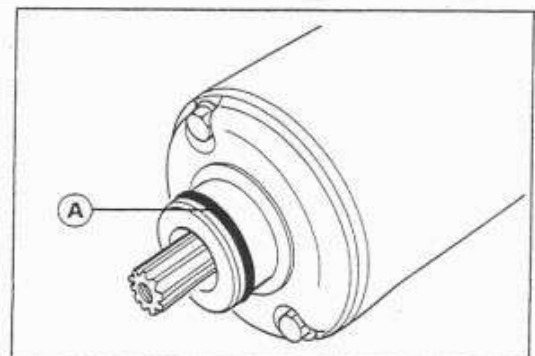



**Starter Motor Disassembly**

- Take off the starter motor through bolts [A] and remove both end covers [B] and, then pull the armature out of the yoke [C].

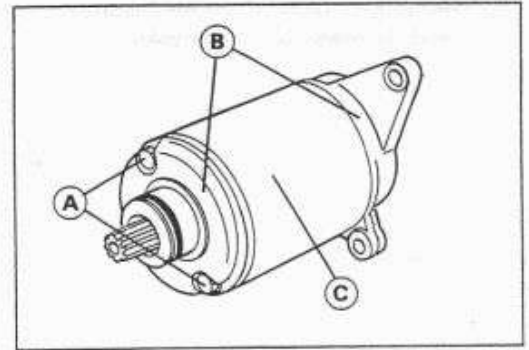

- The brush plate [A] and brushes come off with the left-hand end cover [B].

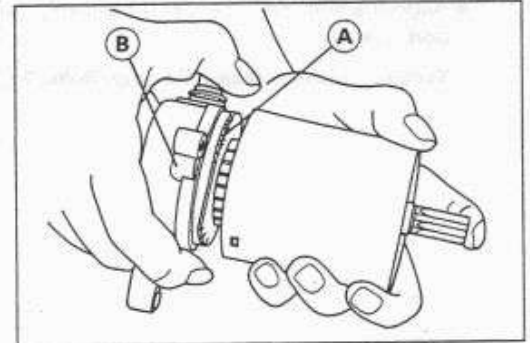

- Remove the terminal locknut [A] and terminal bolt [B], and then remove the brush with the brush plate [C] from the left-hand end cover.

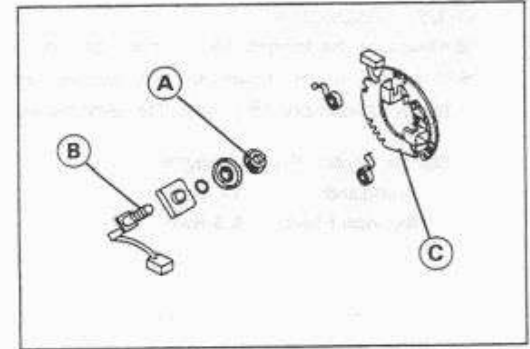
**Starter Motor Assembly**

- Install the brush plate and brushes [A], and then put the armature [B] among the brushes.

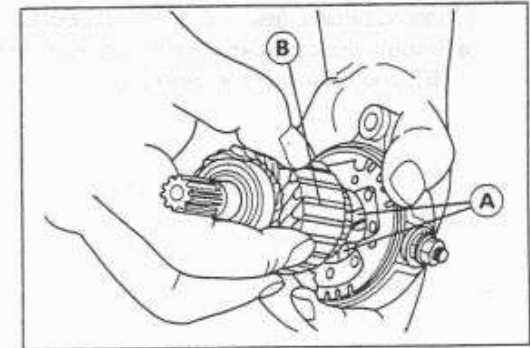

- Install the O-rings [A] as shown.

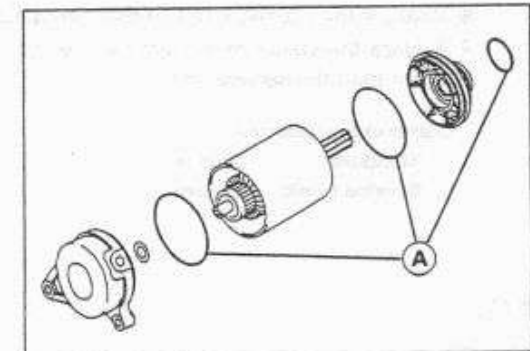

- Align the notch [A] in the brush plate with the end cover notch [B] and the mark [C] on the yoke.

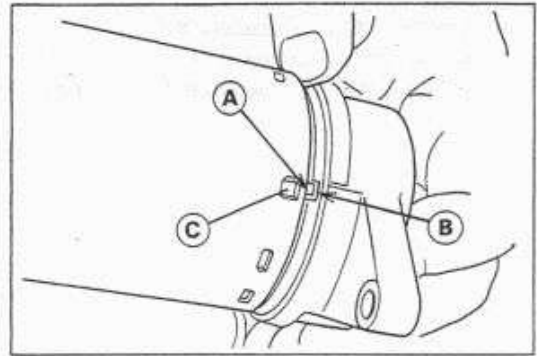

- Align the lines [A] marked on the yoke with the right-hand end cover bolt hole [B].

**Torque – Starter Motor Through Bolts: 5.9 N-m (0.60 kg-m, 52 in-lb)**

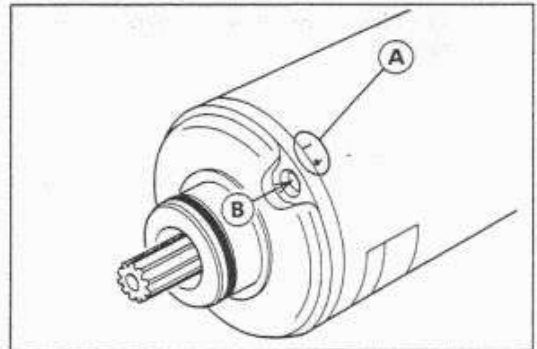

**Brush Inspection**

- Measure the length [A] of each brush.
- ★ If any is worn down to the service limit, replace the carbon brush holder assembly [B] and the terminal bolt assembly [C].

**Starter Motor Brush Length**

**Standard: 12 mm**  
**Service Limit: 8.5 mm**

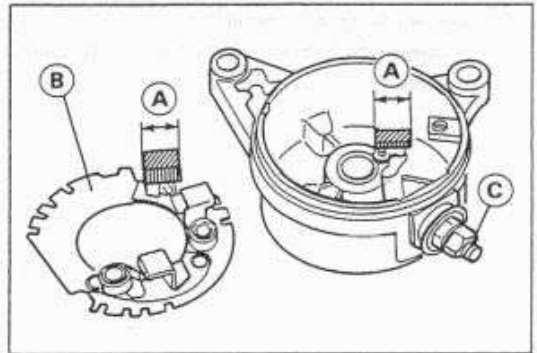

**Commutator Cleaning and Inspection**

- Smooth the commutator surface [A] if necessary with fine emery cloth [B], and clean out the grooves.

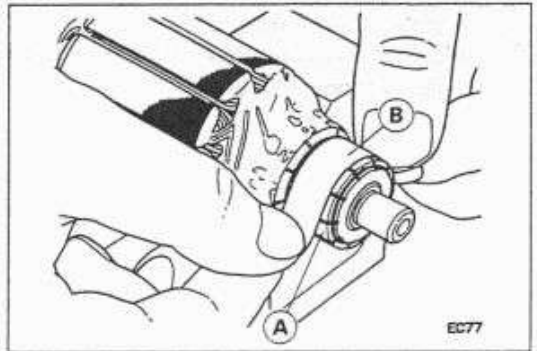

- Measure the diameter [A] of the commutator [B].
- ★ Replace the starter motor with a new one if the commutator diameter is less than the service limit.

**Commutator Diameter**

**Standard: 28 mm**  
**Service Limit: 27 mm**

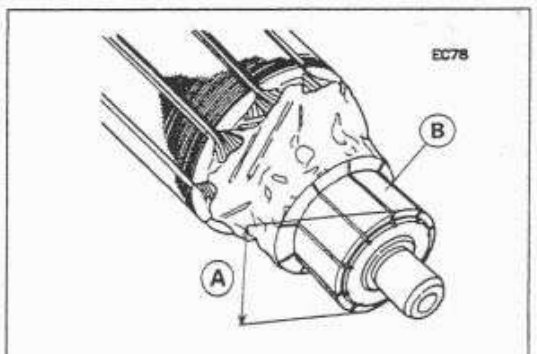

### Armature Inspection

- Using the x 1  $\Omega$  hand tester range, measure the resistance between any two commutator segments [A].
- ★ If there is a high resistance or no reading ( $\infty$ ) between any two segments, a winding is open and the starter motor must be replaced.
- Using the highest hand tester range, measure the resistance between the segments and the shaft [B].
- ★ If there is any reading at all, the armature has a short and the starter motor must be replaced.

#### NOTE

○ Even if the foregoing checks show the armature to be good, it may be defective in some manner not readily detectable with the hand tester. If all other starter motor and starter motor circuit components check good, but the starter motor still does not turn over or only turns over weakly, replace the starter motor with a new one.

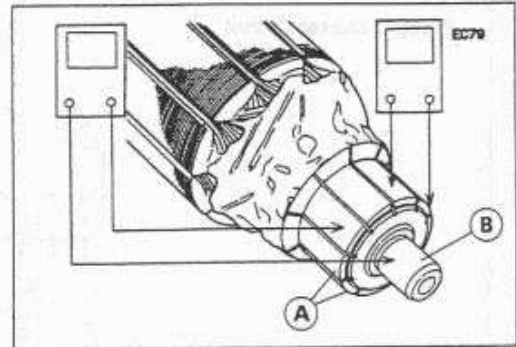

### Brush Lead Inspection

- Using the x 1  $\Omega$  hand tester range, measure the resistance as shown.
  - [A] Terminal Bolt and Positive Brush
  - [B] Brush Plate and Negative Brush
- ★ If there is not close to zero ohms, the brush lead has an open. Replace the terminal bolt assembly and/or the brush holder assembly.

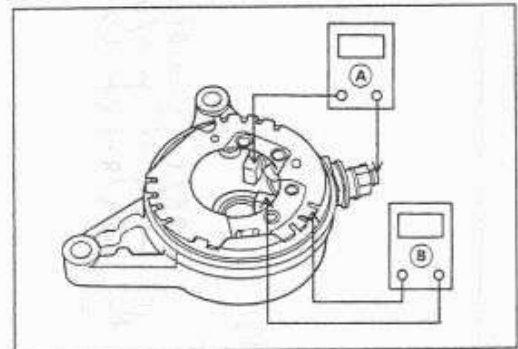

### Brush Plate and Terminal Bolt Inspection

- Using the highest hand tester range, measure the resistance as shown.
  - [A] Terminal Bolt and Left-hand End Cover
  - [B] Terminal Bolt and Brush Plate
- ★ If there is any reading, the brush holder assembly and/or terminal bolt assembly have a short. Replace the brush holder assembly and the terminal bolt assembly.

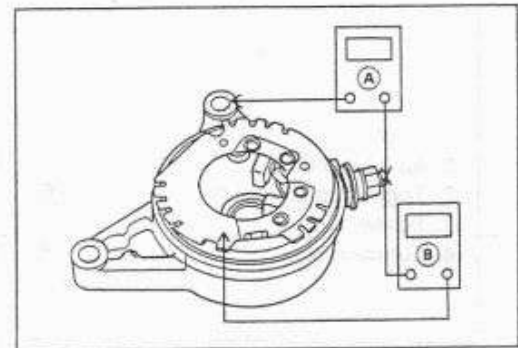

### Starter Relay Inspection

- Remove the seats (see Frame chapter).
- Remove the starter relay.
- Connect the hand tester [A] and 12 V battery [B] to the starter relay [C] as shown.
- ★ If the relay does not work as specified, the relay is defective. Replace the relay.

#### Testing Relay

Tester Range: x 1  $\Omega$  range

Criteria: When battery is connected  $\rightarrow 0 \Omega$

When battery is disconnected  $\rightarrow \infty \Omega$

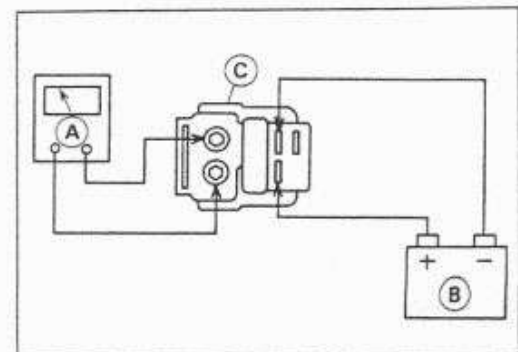

Electric Starter Circuit

EC101

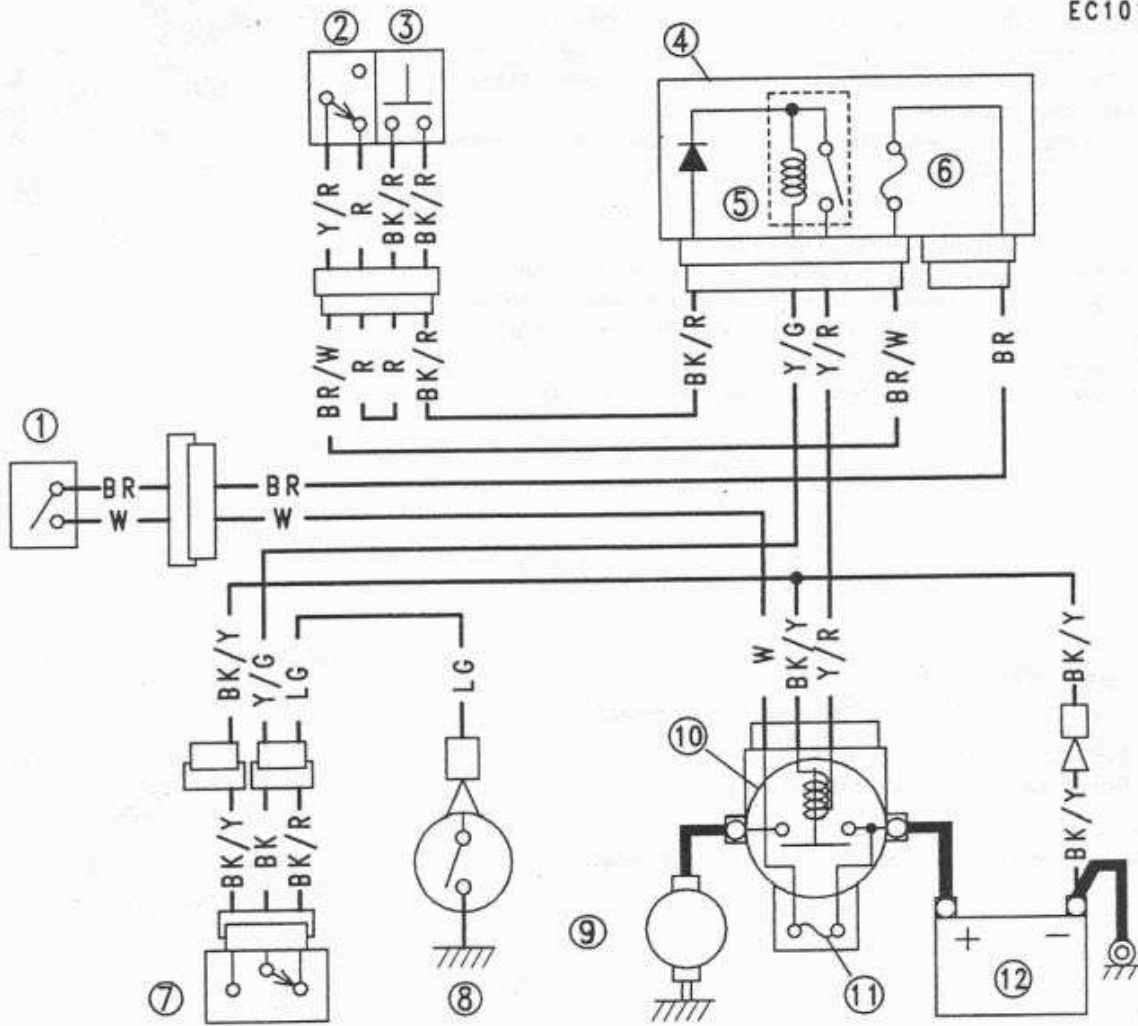

- 1. Ignition Switch
- 2. Engine Stop Switch
- 3. Starter Button
- 4. Junction Box

- 5. Starter Circuit Relay
- 6. Ignition Fuse 10A
- 7. Starter Lockout Switch
- 8. Neutral Switch

- 9. Starter Motor
- 10. Starter Relay
- 11. Main Fuse 30A
- 12. Battery

## Lighting System

The US, Canada, and Australia models adopt the daylight system and have a headlight relay in the junction box. In these models, the headlight does not go on when the ignition switch and the engine stop switch are first turned on. The headlight comes on after the starter button is released and stays on until the ignition switch is turned off. The headlight will go out momentarily whenever the starter button is pressed and come back on when the button is released.

### Headlight Beam Horizontal Adjustment

- Turn the horizontal adjusters [A] on the headlights in or out until both beams point straight ahead.

### Headlight Beam Vertical Adjustment

- Turn the vertical adjusters [B] on the headlights in or out to adjust the headlights vertically.

#### NOTE

- On high beam, the brightest points should be slightly below horizontal with the motorcycle on its wheels and the rider seated. Adjust the headlight(s) to the proper angle according to local regulations.
- For US model, the proper angle is 0.4 degrees below horizontal. This is 50 mm (2 in) drop at 7.6 m (25 ft) measured from the center of the headlights with the motorcycle on its wheels and the rider seated.

50 mm (2 in) [A]  
Center of Brightest Spot [B]  
7.6 m (25 ft) [C]  
Height of Headlight Center [D]

### Headlight Bulb Replacement

- Remove:
  - Headlight Connector
  - Headlight Bulb Dust Cover [A]
  - Hook [B]

#### CAUTION

When handling the quartz-halogen bulb, never touch the glass portion with bare hands. Always use a clean cloth. Oil contamination from hands or dirty rags can reduce bulb life or cause the bulb to explode.

- Replace the headlight bulb.
- Fit the dust cover [A] with the Top mark [B] upward onto the bulb [C] firmly as shown.
- After installation, adjust the headlight aim (see this chapter).

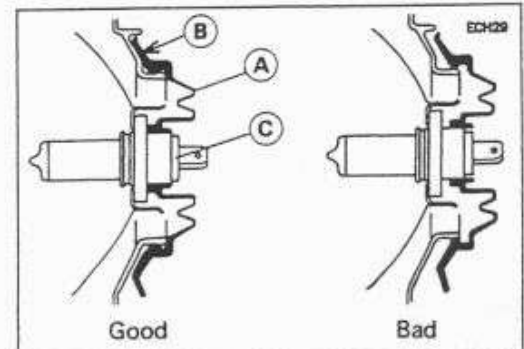
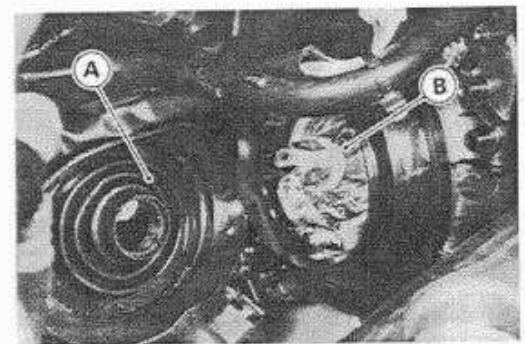
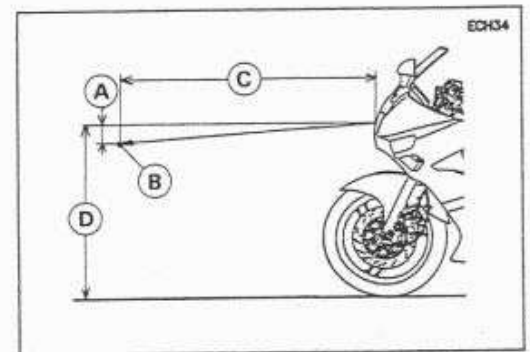
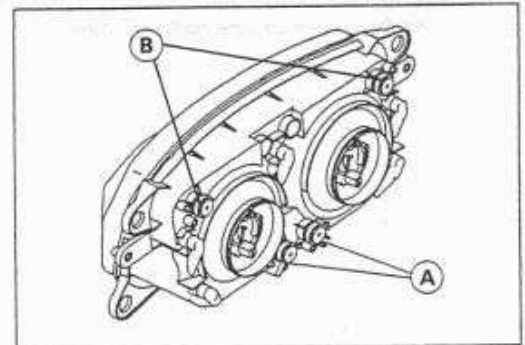

**Headlight Diode Inspection (Europe models except U.K.)**

- Remove the upper fairing.
- Pull the diode [A] out of the main harness.
- Zero the hand tester (special tool), and connect it to each terminal to check the resistance in both directions.
- The resistance should be low in one direction and more than ten times as much in the other direction.
- ★ If the diode shows low or high in both directions, the diode is defective and the diode must be replaced.

**NOTE**

- The actual meter reading varies with the meter used and the individual diode, but, generally speaking, the lower reading should be from zero to one half the scale.

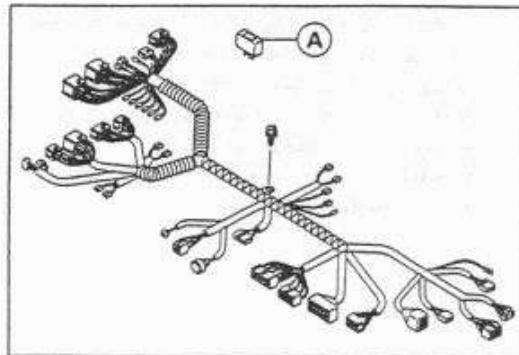

## Headlight Circuit (U.S. and Canada)

ECH105

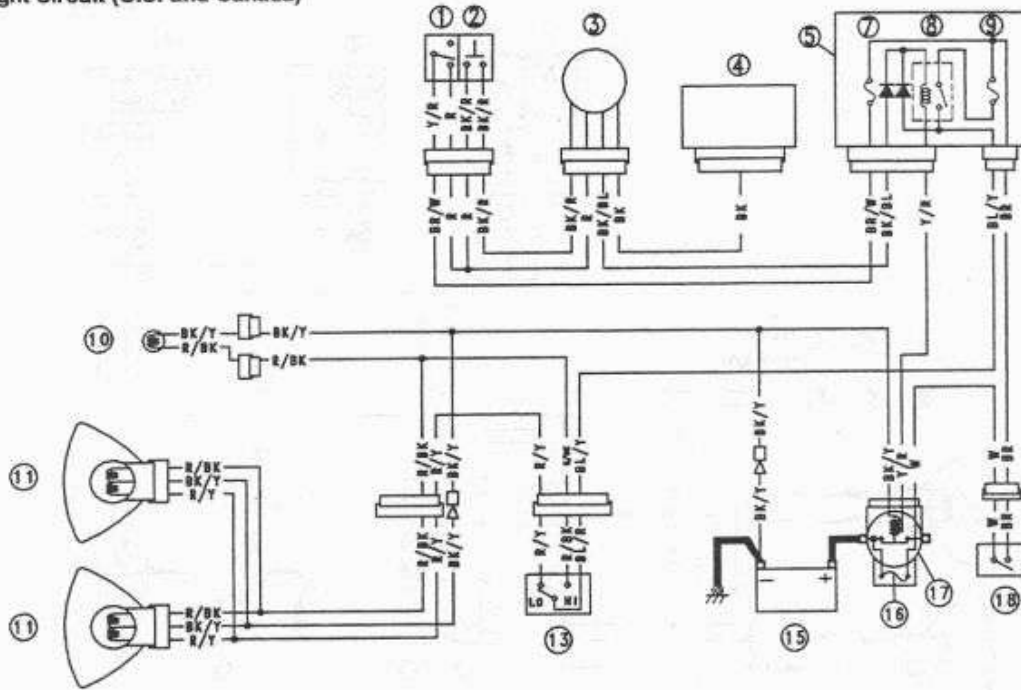

## Headlight Circuit (Australia)

ECH104

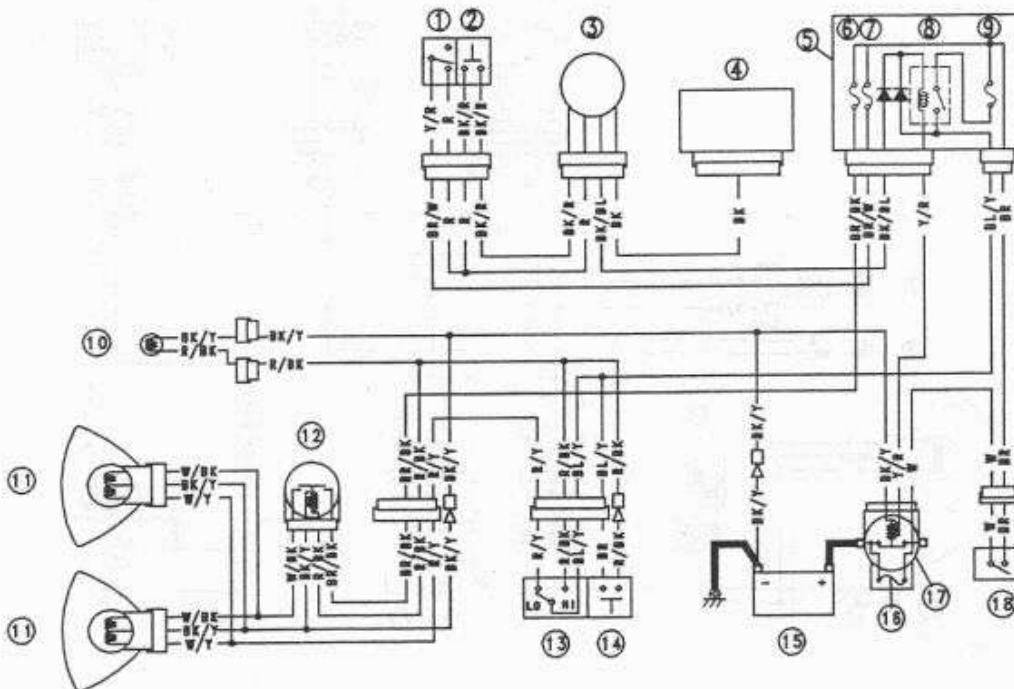

1. Engine Stop Switch

2. Starter Button

3. Fuel Pump Relay

4. IC Igniter

5. Junction Box

6. High Beam &amp; Horn Fuse 10A

7. Ignition Fuse 10A

8. Headlight Relay

9. Headlight Fuse 10A

10. High Beam Indicator Light

11. Headlights

12. High Beam Relay

13. Dimmer Switch

14. Passing Button

15. Battery

16. Main Fuse 30A

17. Starter Relay

18. Ignition Switch

Headlight Circuit (Europe except U.K.)

ECH103

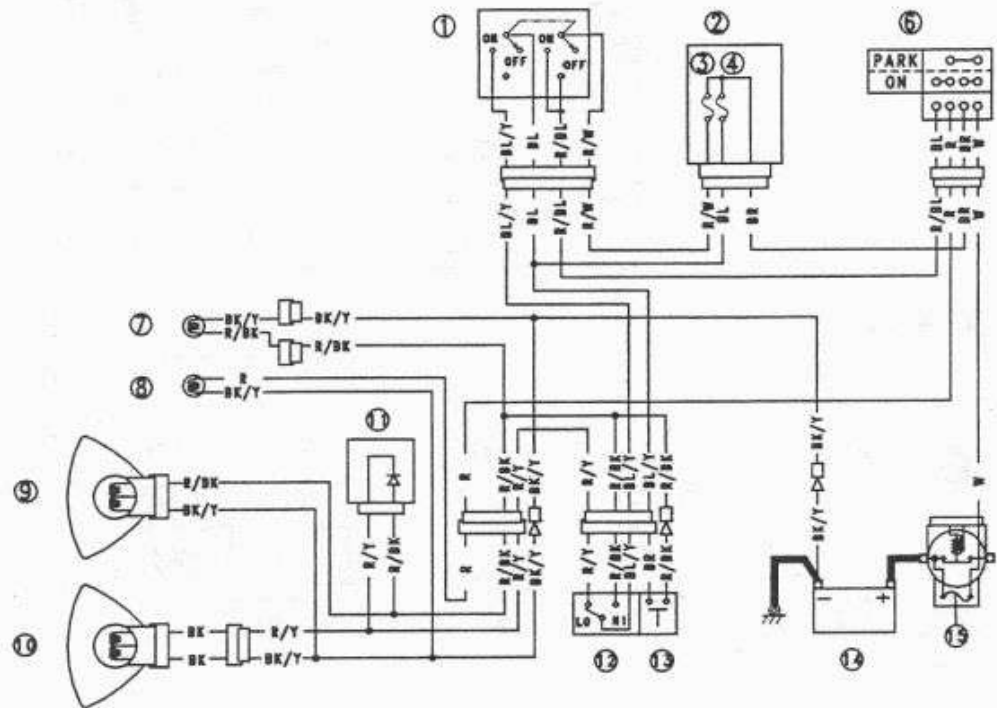

Headlight Circuit (U.K.)

ECH102

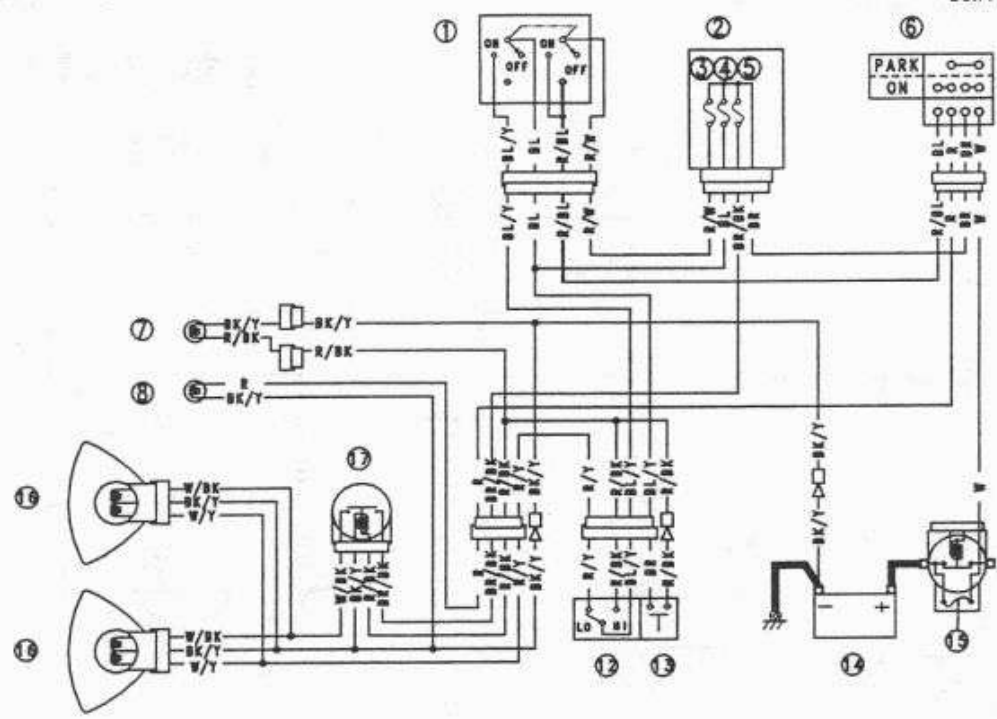

- |                              |                              |                     |
|------------------------------|------------------------------|---------------------|
| 1. Headlight Switch          | 7. High Beam Indicator Light | 13. Passing Button  |
| 2. Junction Box              | 8. City Light                | 14. Battery         |
| 3. Taillight Fuse 10A        | 9. Right Headlight (High)    | 15. Main Fuse 30A   |
| 4. Headlight Fuse 10A        | 10. Left Headlight (Low)     | 16. Headlights      |
| 5. High Beam & Horn Fuse 10A | 11. Diode                    | 17. High Beam Relay |
| 6. Ignition Switch           | 12. Dimmer Switch            |                     |



**Turn Signal Relay Inspection**

## ● Remove:

- Seats (see Frame chapter)
- Side Cover (see Frame chapter)
- Turn Signal Relay [A]

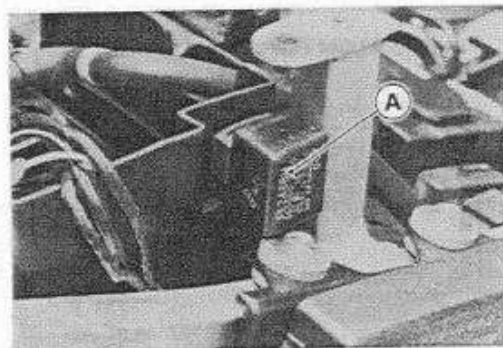

- Connect one 12 V battery and turn signal lights as indicated in the figure, and count how many times the lights flash for one minute.

- [A] Turn Signal Relay
- [B] Turn Signal Lights
- [C] 12 V Battery

- ★ If the lights do not flash as specified, replace the turn signal relay.

**Testing Turn Signal Relay**

Load		Flashing times (c/m*)
The Number of Turn Signal Lights	Wattage(W)	
1	21 or 23	Light stays on
2	42 or 46	75 - 95

(\*): Cycle(s) per minute

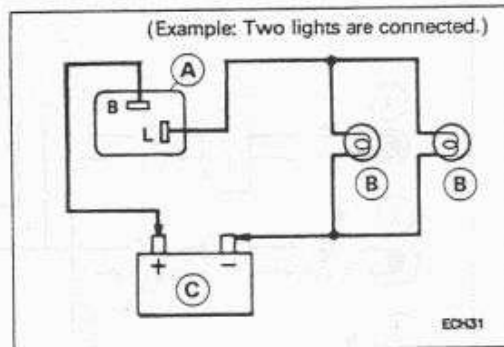

Turn Signal Light Circuit

ECH101

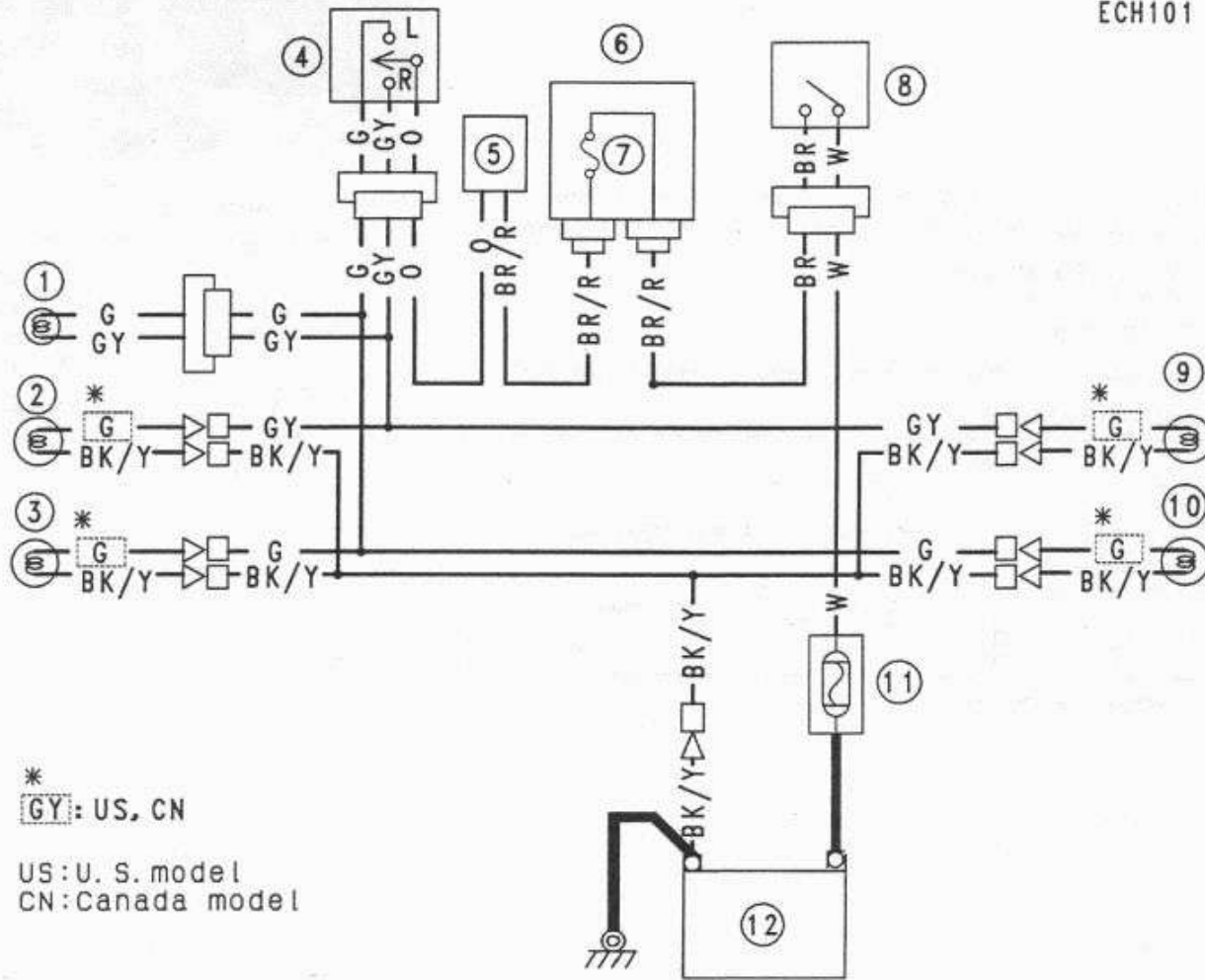

- 1. Turn Signal Indicator Light
- 2. Front Right Turn Signal Light
- 3. Front Left Turn Signal Light
- 4. Turn Signal Switch

- 5. Turn Signal Relay
- 6. Junction Box
- 7. Turn Signal Fuse 10A
- 8. Ignition Switch

- 9. Rear Right Turn Signal Light
- 10. Rear Left Turn Signal Light
- 11. Main Fuse 30A
- 12. Battery

## Fuel Pump

- The fuel pump [A] operates when the starter button is pushed on or the engine is running.
- When fuel level in the float chamber is low, the fuel pump operates to supply fuel into the float chamber. When the fuel reaches a certain level, the fuel pressure rises, and the fuel pump stops.

### Removal/Installation

- Refer to Fuel System chapter.

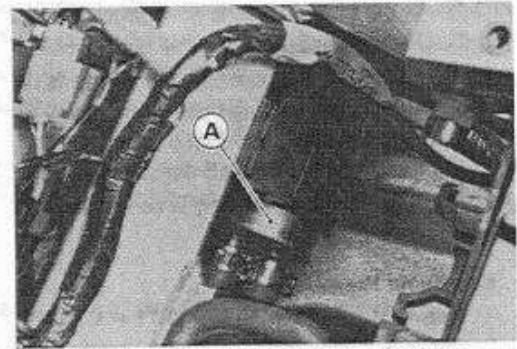

### Fuel Pump Relay Inspection

- Remove the seats (see Frame chapter).
- Take off the fuel pump relay [A].
- Set the hand tester to the x 1 kΩ range and make the measurements shown in the table.

**Special Tool – Hand Tester: 57001-1394**

- ★ If the tester readings are not as specified, replace the fuel pump relay.
- ★ If the tester readings are normal, check the fuel pump operation.

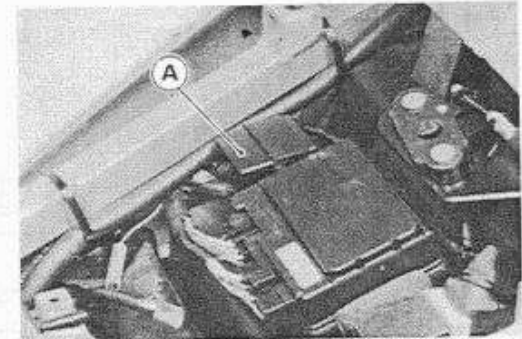

### CAUTION

Use only Hand Tester 57001-1394 for this test. An ohmmeter other than the Kawasaki Hand Tester may show different readings. If a megger or a meter with a large-capacity battery is used, the pump relay will be damaged.

### Fuel Pump Relay Internal Resistance

Range	Tester (+) Lead Connection			
	1	2	3	4
* x 1 kΩ				
(-)	1	∞	∞	∞
	2	∞	∞	∞
	3	∞	10 ~ 100	∞
	4	∞	20 ~ 200	1 ~ 5

(-)\* : Tester (-) Lead Connection

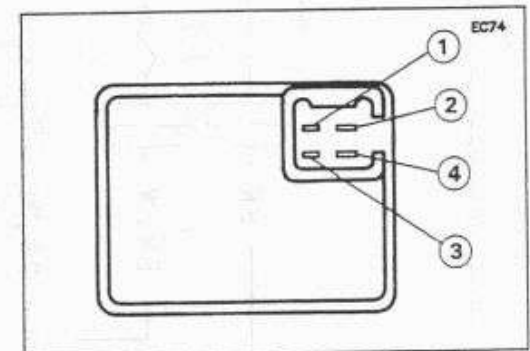

### Fuel Pump Operational Inspection

- Remove the fuel pump with the fuel filter (see Fuel System chapter).
- Prepare a container filled with kerosene.
- Prepare the rubber hoses, and connect them to the pump fittings.
- Connect the suitable pressure gauge to the outlet hose as shown.

Fuel Pump [A]  
 Pressure Gauge [B]  
 Outlet Hose [C]  
 Inlet Hose [D]  
 Fuse Filter [E]  
 Kerosene [F]  
 2-Pin Connector [G]  
 Battery [H]  
 Auxiliary Leads [I]

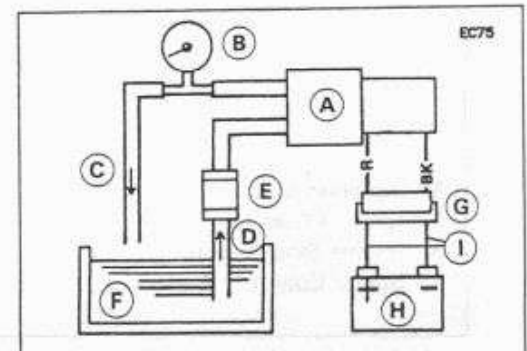

- Connect the pump leads to the battery using auxiliary wires as shown.
- ★ If the pump operates, check the pump relay.
- ★ If the pump does not operate, the pump is defective.
- ★ If the pump operates and the pump relay is normal, close the outlet hose while operating the fuel pump.
- When the pump stops, read the pressure gauge.
- ★ If the pressure gauge reading is out of the specified pressure, the pump is defective.

**Fuel Pump Pressure**

**Standard** : 11 ~ 16 kPa (0.11 ~ 0.16 kg/cm<sup>2</sup>, 1.6 ~ 2.3 psi)

**Fuel Pump Circuit**

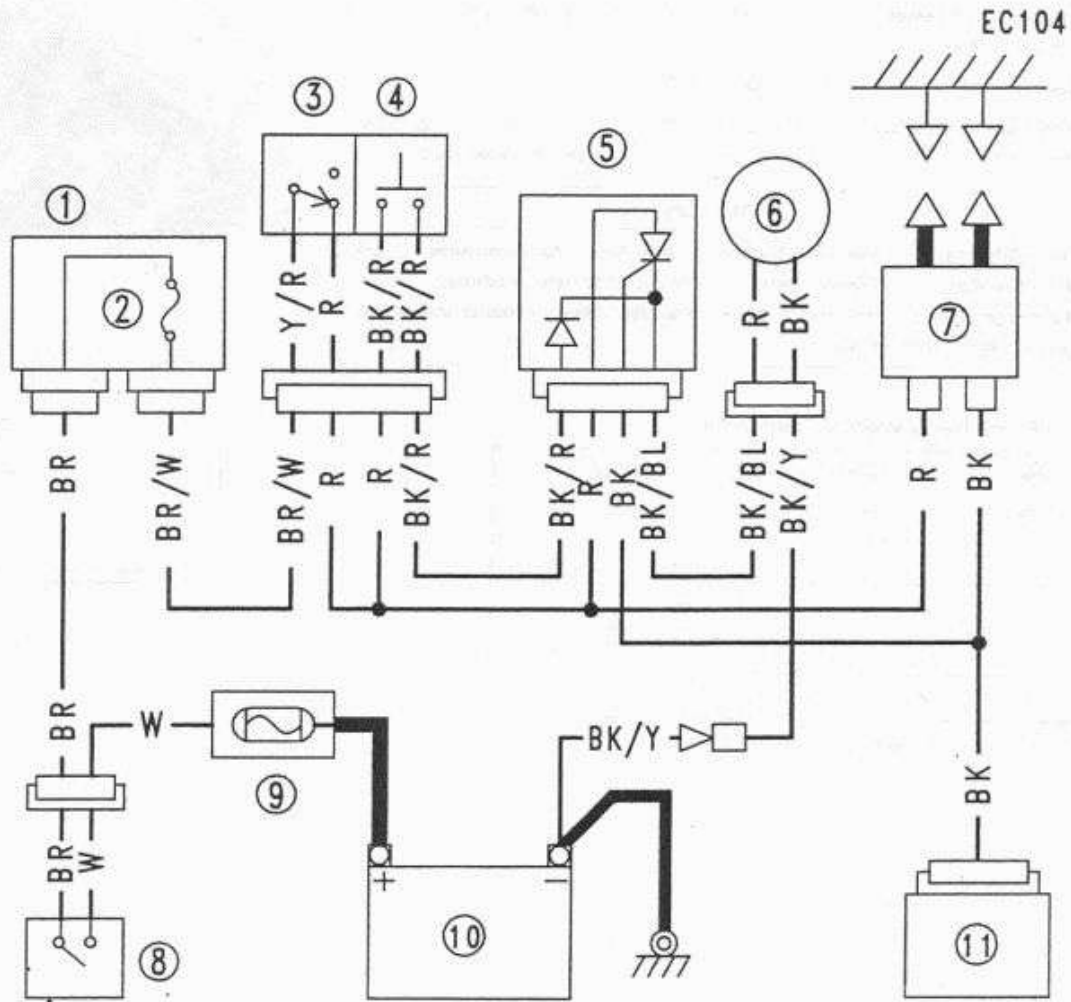

- 1. Junction Box
- 2. Ignition Fuse 10A
- 3. Engine Stop Switch
- 4. Starter Button

- 5. Fuel Pump Relay
- 6. Fuel Pump
- 7. Ignition Coil
- 8. Ignition Switch

- 9. Main Fuse 30A
- 10. Battery
- 11. IC Igniter

## Radiator Fan System

### Fan System Circuit Inspection

- Disconnect the leads from the radiator fan switch [A].
- Using an auxiliary wire [B], connect the radiator fan switch leads.
- ★ If the fan rotates, inspect the fan switch.
- ★ If the fan does not rotate, inspect the following.
  - Leads and Connectors
  - Main Fuse and Fan Fuse
  - Fan Motor

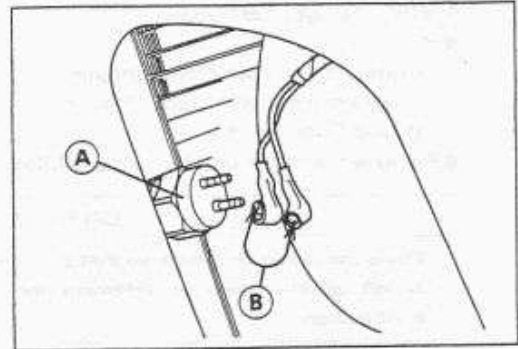

### Fan Motor Inspection

- Disconnect the 2-pin connector [A] in the fan motor leads.
- Using two auxiliary wires, supply battery [B] power to the fan motor.
- ★ If the fan does not rotate, the fan motor is defective and must be replaced.

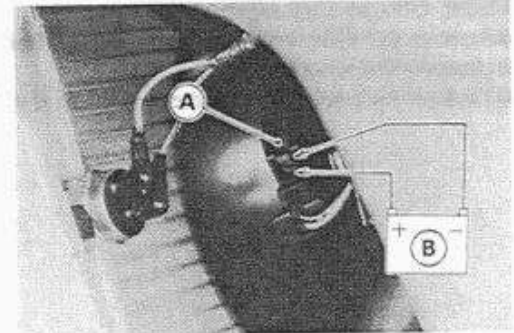

Radiator Fan Circuit

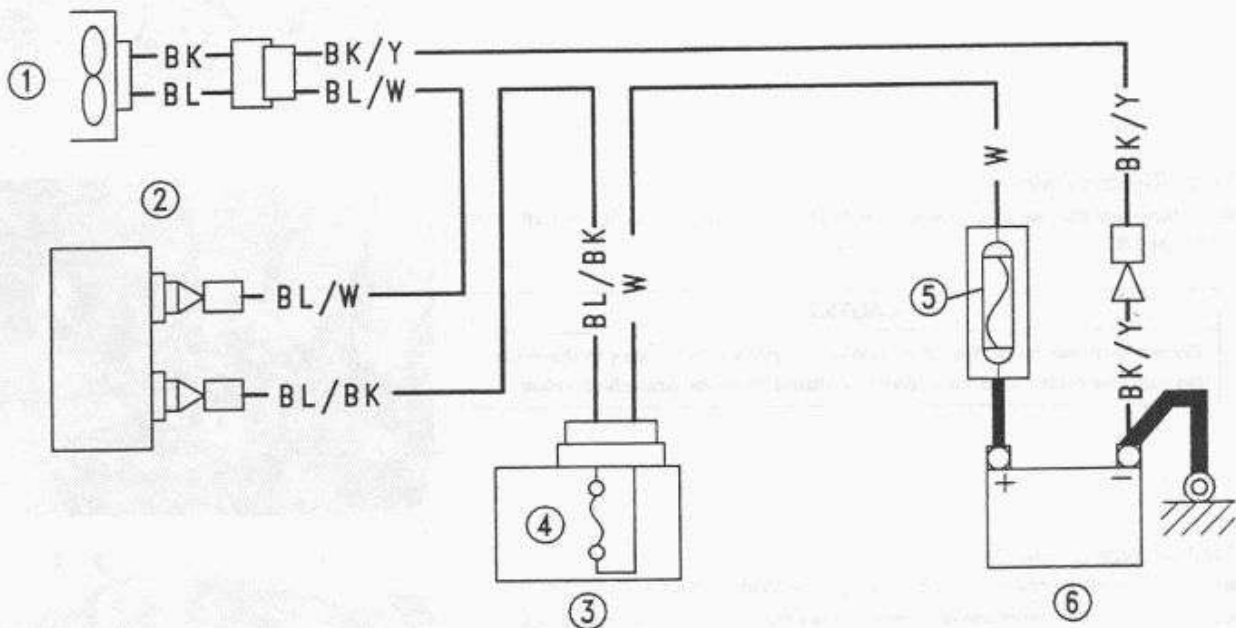

1. Radiator Fan
2. Radiator Fan Switch

3. Junction Box
4. Fan Fuse 10A

5. Main Fuse 30A
6. Battery

## Meters, Gauge

### Meter, Gauge Removal

- Remove:
  - Upper Fairing (see Frame chapter)
  - Speedometer Cable Upper End [A]
  - Wiring Connectors
- Remove the meter unit by taking off the mounting nuts [B].

#### CAUTION

Place the meter or gauge so that the face is up. If a meter or gauge is left upside down or sideways for any length of time, it will malfunction.

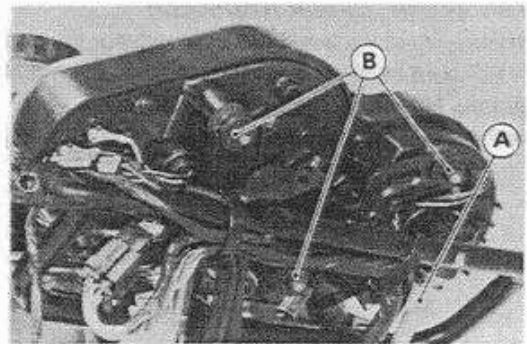

### Meter, Gauge Disassembly

- Remove the meter unit (see Meter, Gauge Removal).
- Unscrew the reset knob screw [A].
- Take off the cover [B] by removing the screws [C].

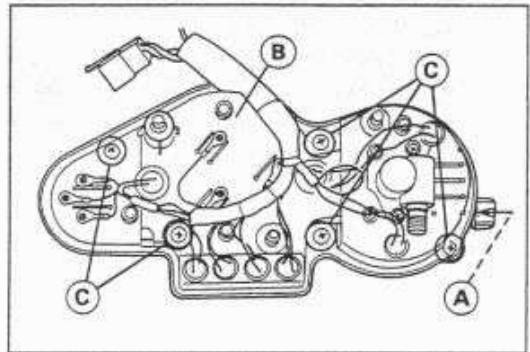

- Remove the screws [A] for removal of each unit.
  - Water Temperature Gauge [B]
  - Tachometer [C]
  - Speedometer [D]

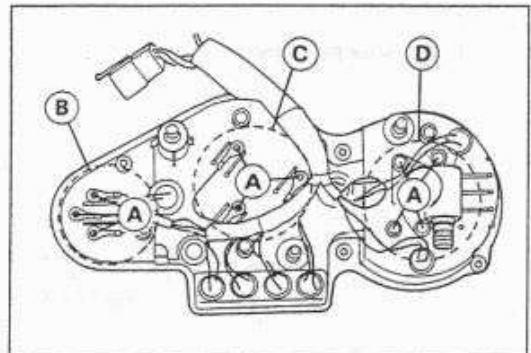

### Bulb Replacement

- To remove the wedge-base type bulb [A], pull the bulb out of the socket [B].

#### CAUTION

Do not turn the bulb. Pull the bulb out to prevent damage to the bulb. Do not use bulb rated for greater wattage than the specified value.

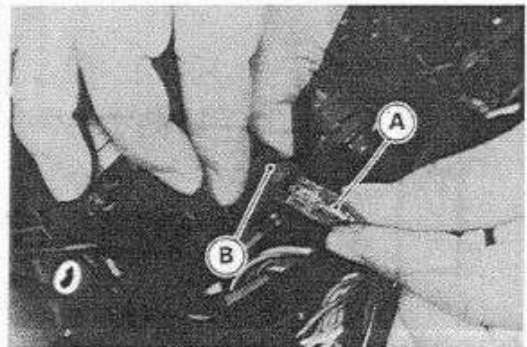

### Tachometer Inspection

- Check the tachometer circuit wiring (see Wiring Inspection).
- ★ If all wiring and components other than the tachometer unit check out good, the unit is suspect. Check the unit as shown.
  - Remove the upper fairing (see Frame chapter).
  - Remove the BK lead [A] and retighten the terminal screw [B] only.
  - Turn the ignition switch ON.
  - Using an auxiliary wire [C], open and connect the BR lead terminal [D] to the BK lead terminal [B] repeatedly.

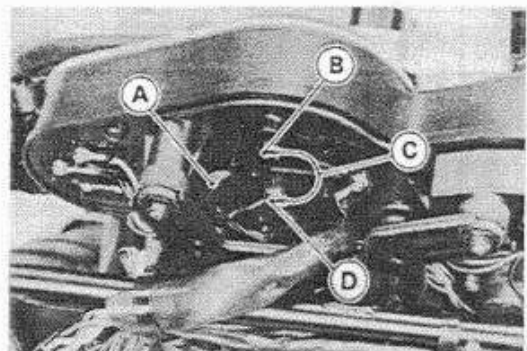

- Then the tachometer hand [A] should flick [B].
- Turn the ignition switch OFF.
- ★ If the hand does not flick, replace the tachometer unit.

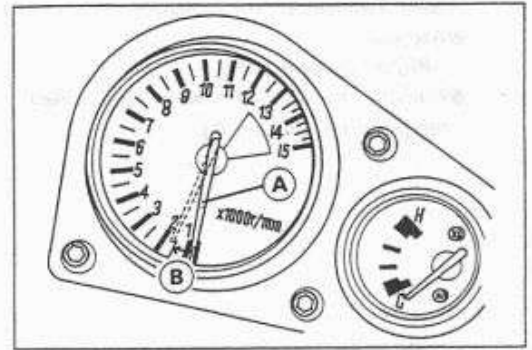

## Tachometer Circuit

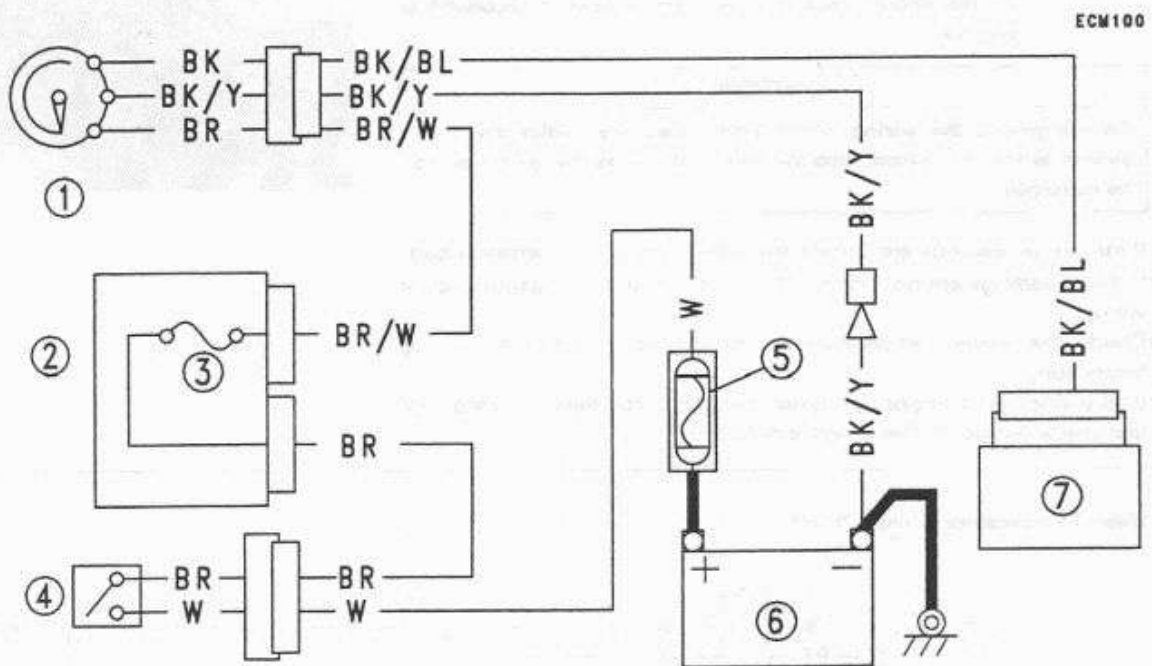

1. Tachometer
2. Junction Box
3. Ignition Fuse 10A

4. Ignition Switch
5. Main Fuse 30A
6. Battery

7. IC Igniter

**Water Temperature Gauge Inspection**

- Remove:
  - Right Lower Fairing
- Prepare an auxiliary wire, and check the operation of the water temperature gauge [A].

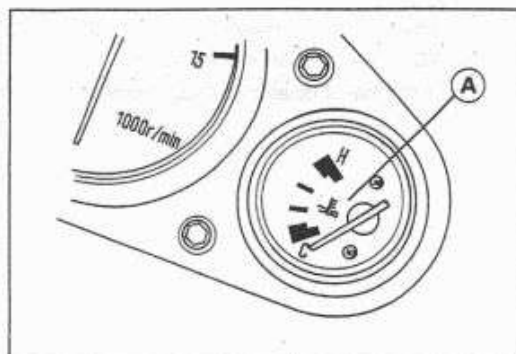

**Gauge Operation Test**

Ignition Switch Position: ON

Wire Location: Water temperature sensor female connector (disconnected)

Results: Gauge should read C when sensor lead [A] is opened.  
Gauge should read H when sensor lead is grounded to engine.

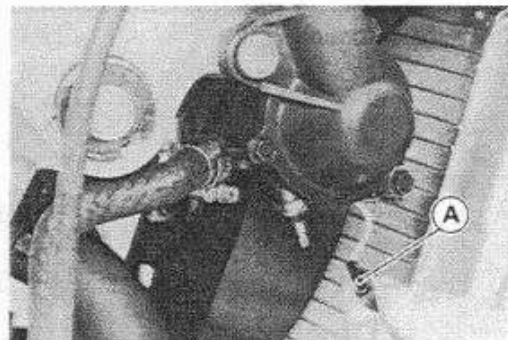

**CAUTION**

Do not ground the wiring longer than necessary. After the hand swings to the H position, stop the test. Otherwise the gauge could be damaged.

- ★ If the gauge readings are correct, the water temperature sensor is bad.
- ★ If these readings are not correct, the trouble is with the gauge and/or wiring.
- Check the water temperature gauge circuit wiring (see Wiring Inspection).
- If all wiring and components other than the water temperature gauge unit check out good, the gauge is defective.

**Water Temperature Gauge Circuit**

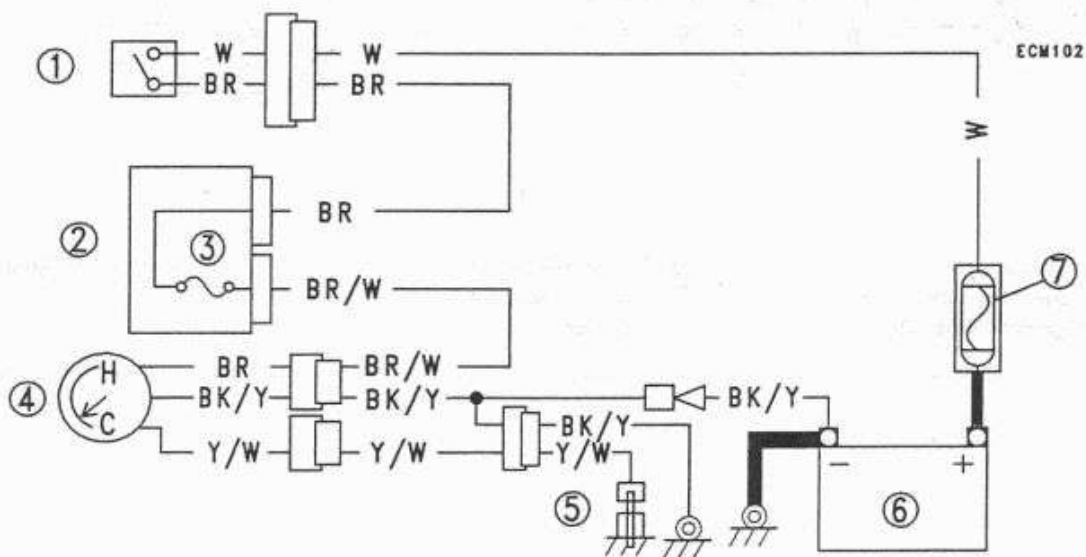

- 1. Ignition Switch
- 2. Junction Box
- 3. Ignition Fuse 10A

- 4. Water Temperature Gauge
- 5. Water Temperature Sensor
- 6. Battery

- 7. Main Fuse 30A



## Switches and Sensors

### Brake Light Timing Inspection

- Turn on the ignition switch.
- Check the operation of the rear brake light switch by depressing the brake pedal.
- If it does not as specified, adjust the brake light timing.

#### Brake Light Timing

**Standard:** On after about 10 mm of pedal travel [A]

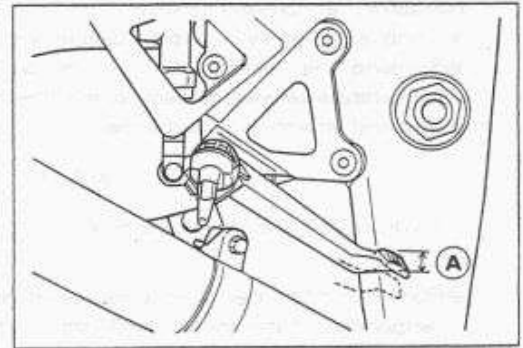

### Brake Light Timing Adjustment

Brake light timing is adjusted by changing the position of the rear brake light switch.

- Adjust the position of the switch so that the brake light goes on after the specified pedal travel by turning the adjusting nut [A].

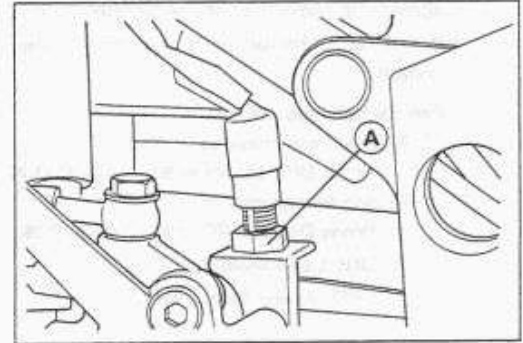

#### CAUTION

To avoid damaging the electrical connections inside the switch, be sure that the switch body does not turn during adjustment.

### Switch Inspection

- Using a hand tester, check to see that only the connections shown in the table have continuity (about zero ohms).
- For the handlebar switches and the ignition switch, refer to the tables in the Wiring Diagram.
- ★ If the switch has an open or short, repair it to or replace it with a new one.

**Special Tool – Hand Tester: 57001-1394**

#### Rear Brake Light Switch Connections

	BR	BL
When brake pedal is pushed down	○ ——— ○	
When brake pedal is released		

#### Side Stand Switch Connections

	G/W	BK/Y
When side stand is up	○ ——— ○	
When side stand is down		

#### Neutral Switch Connections

	SW. Terminal	⏏
When transmission is in neutral	○ ——— ○	
When transmission is not in neutral		

#### Oil Pressure Switch Connections\*

	SW. Terminal	⏏
When engine is stopped	○ ——— ○	
When engine is running		

\*: Engine lubrication system is in good condition

**Radiator Fan Switch Inspection**

- Remove the fan switch (see Cooling System chapter).
- Suspend the switch [A] in a container of coolant so that the temperature-sensing projection and threaded portion are submerged.
- Suspend an accurate thermometer [B] in the coolant.

**NOTE**

○ The switch and thermometer must not touch the container sides or bottom.

- Place the container over a source of heat and gradually raise the temperature of the coolant while stirring the coolant gently.
- Using the hand tester, measure the internal resistance of the switch across the terminals at the temperatures shown in the table.
- ★ If the hand tester does not show the specified values, replace the switch.

**Fan Switch Resistance**

- Rising temperature:
  - From OFF to ON at 93 ~ 103°C (199 ~ 217°F)
- Falling temperature:
  - From ON to OFF at 91 ~ 95°C (196 ~ 203°F)
  - ON: Less than 0.5 Ω
  - OFF: More than 1 MΩ

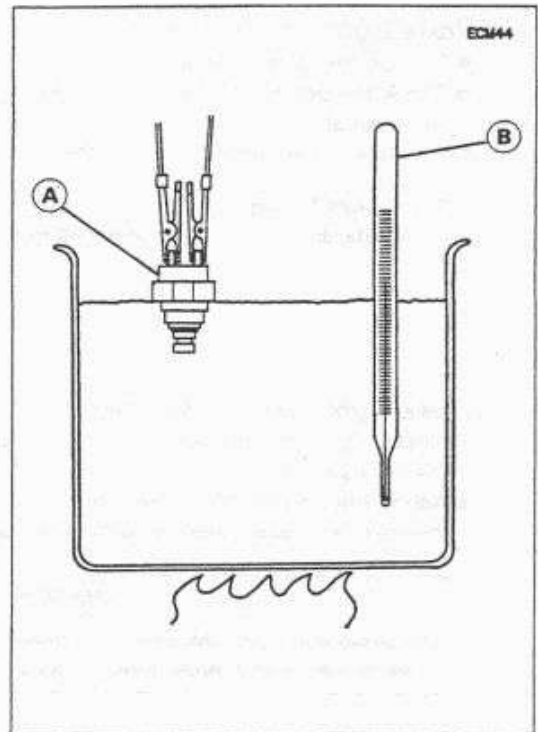

**Water Temperature Sensor Inspection**

- Remove the water temperature sensor (see Cooling System chapter).
- Suspend the sensor [A] in a container of coolant so that the temperature-sensing projection and threaded portion are submerged.
- Suspend an accurate thermometer [B] in the coolant.

**NOTE**

○ The sensor and thermometer must not touch the container side or bottom.

- Place the container over a source of heat and gradually raise the temperature of the coolant while stirring the coolant gently.
- Using the hand tester, measure the internal resistance of the sensor across the terminal and the body at the temperatures shown in the table.
- ★ If the hand tester does not show the specified values, replace the sensor.

**Water Temperature Sensor**

- 80°C (176°F): 47 ~ 57 Ω
- 100°C (212°F): 26 ~ 30 Ω

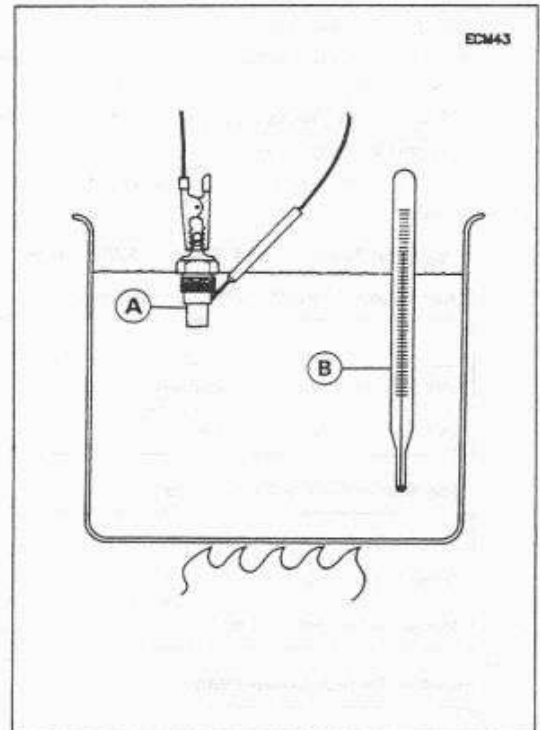

**Throttle Switch Inspection (ZX750N)**

- Remove the fuel tank (see Fuel System chapter).
- Turn off the ignition switch.
- Pull off the throttle switch connector [A].
- Connect the hand tester between the connector terminals.
- Set the tester to the × 1 Ω range.
- Open and close the throttle grip, and read the tester.

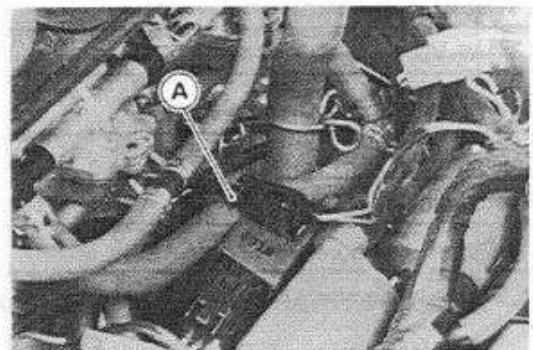

**CAUTION**

Do not open and close the throttle excessively. The accelerator pump can flood the engine, and cause starting difficulty.

**Testing Throttle Switch**

Tester Range:  $\times 1 \Omega$  range

**Criteria:**

When throttle grip is opened

(Throttle valve opening is more than  $3/8$ )  $\rightarrow 0 \Omega$

When throttle grip is closed

(Throttle valve opening is  $3/8$  or less)  $\rightarrow \infty \Omega$

- ★ If the tester does not read as specified, the throttle switch is defective.
- Remove the air cleaner housing, and replace the throttle switch [A].

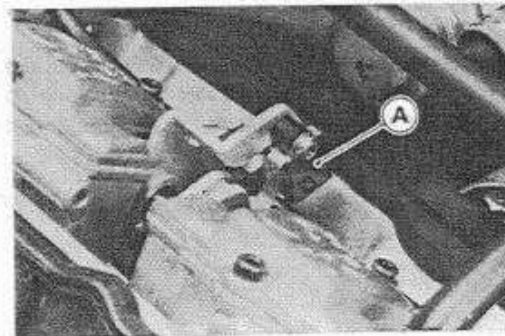

Fuel Enricher Solenoid Valve (ZX750N)

Fuel Enricher Solenoid Valve Inspection

- Remove:
  - Fuel Tank (see Fuel System chapter)
  - Fuel Enricher Solenoid Valve [A]

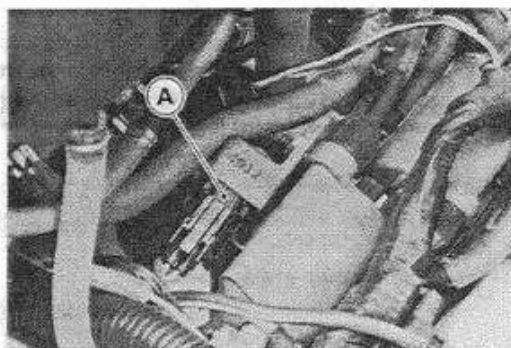

- Check the valve operation using one 12 V battery to the connector as shown.
- When the battery is connected, the valve opens and permits air to flow. When the battery is disconnected, the valve stops air flow.
- ★ If the valve does not operate as described, replace it with a new one.

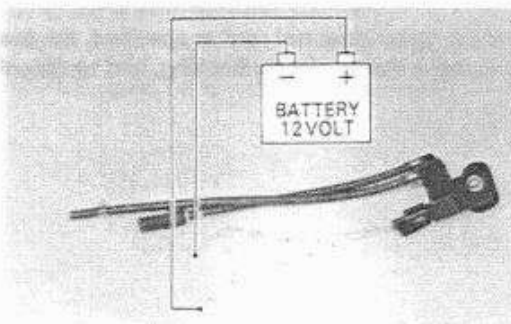

NOTE

○ To check air flow through the fuel enricher solenoid valve, just blow through the hoses.

Fuel Enricher Solenoid Valve Circuit

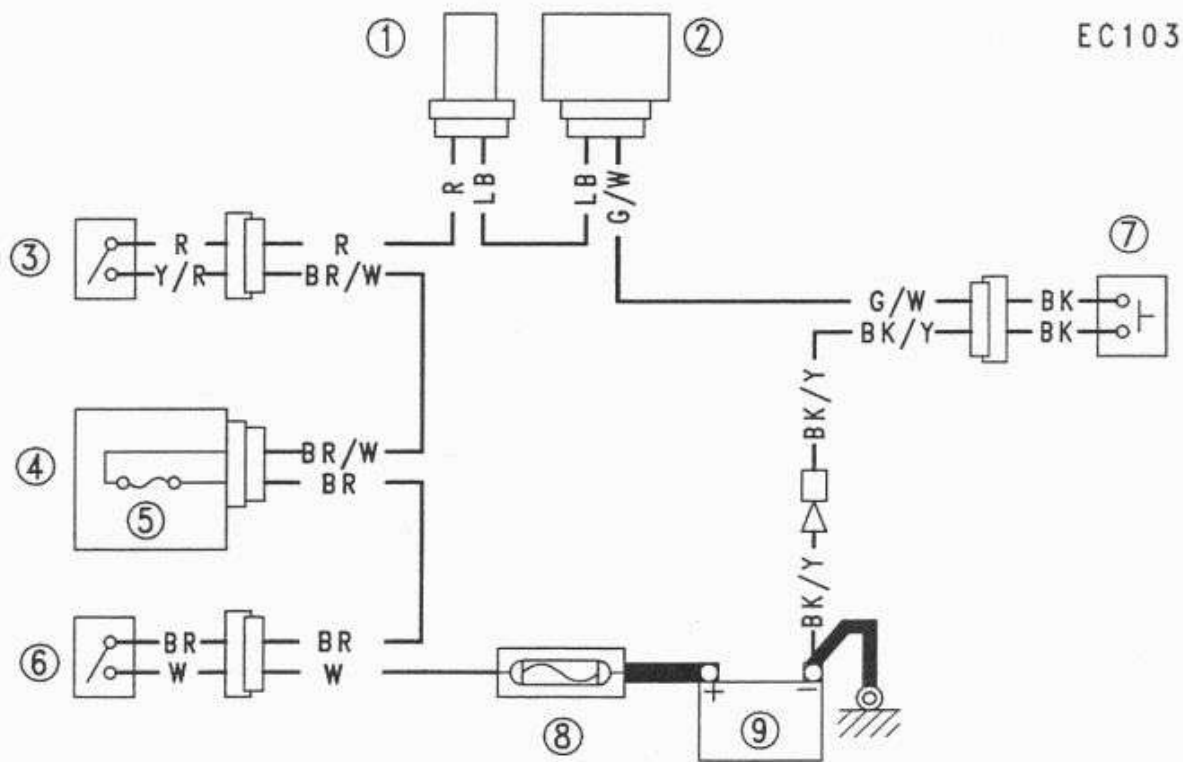

- |                                 |                      |                    |
|---------------------------------|----------------------|--------------------|
| 1. Fuel Enricher Solenoid Valve | 4. Junction Box      | 7. Throttle Switch |
| 2. IC Igniter                   | 5. Ignition Fuse 10A | 8. Main Fuse 30A   |
| 3. Engine Stop Switch           | 6. Ignition Switch   | 9. Battery         |

## Junction Box

The junction box [A] has fuses [B], relays, and diodes. The relays and diodes can not be removed.

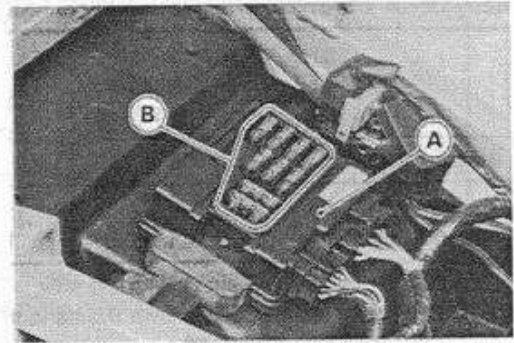

### Junction Box Fuse Circuit Inspection

- Remove the seats (see Frame chapter).
- Remove the seat cover (ZX750N).
- Remove the junction box.
- Pull off the connectors from the junction box.
- Make sure all connector terminals are clean and tight, and none of them have been bent.
- ★ Clean the dirty terminals, and straighten slightly-bent terminals.
- Check conductivity of the numbered terminals with the hand tester.
- ★ If the tester does not read as specified, replace the junction box.

#### Fuse Circuit Inspection

Tester Connection	Tester Reading ( $\Omega$ )
1 - 1A	0
1 - 2	0
3A - 4	0
6 - 5	0
6 - 10	0
6 - 7	0
6 - 17	0

Tester Connection	Tester Reading ( $\Omega$ )
1A - 8	$\infty$
2 - 8	$\infty$
3A - 8	$\infty$
6 - 2	$\infty$
6 - 3A	$\infty$
17 - 3A	$\infty$

### Starter Circuit/Headlight Relay Inspection

- Remove the junction box.
- Check conductivity of the following numbered terminals by connecting the hand tester and one 12 V battery to the junction box as shown.
- ★ If the tester does not read as specified, replace the junction box.

#### Relay Circuit Inspection (with the battery disconnected)

	Tester Connection	Tester Reading ( $\Omega$ )		Tester Connection	Tester Reading ( $\Omega$ )
Headlight Relay	*7 - 8	$\infty$	Starter Circuit Relay	9 - 11	$\infty$
	*7 - 13	$\infty$		12 - 13	$\infty$
	(+) (-) *13 - 9	Not $\infty$ **		(+) (-) 13 - 11	$\infty$
		(+) (-) 12 - 11		Not $\infty$ **	

(\*): US, Canada, and Australia Models only

(\*\*): The actual reading varies with the hand tester used.

(+): Apply tester positive lead.

(-): Apply tester negative lead.

## Relay Circuit Inspection (with the battery connected)

	Battery Connection (+) (-)	Tester Connection	Tester Reading ( $\Omega$ )
Headlight Relay	*9 - 13	*7 - 8	0
Starter Circuit Relay	11 - 12	(+) (-) 13 - 11	Not $\infty$ **

(\*): US, Canada, and Australia Models only

(\*\*): The actual reading varies with the hand tester used.

(+): Apply tester positive lead.

(-): Apply tester negative lead.

## Diode Circuit Inspection

- Remove the junction box.
- Check conductivity of the following pairs of terminals.

### Diode Circuit Inspection

Tester Connection	*13-8, *13-9, 12-11, 12-14, 15-14, 16-14
-------------------	--

\*: US, Canada, and Australia Models only

★The resistance should be low in one direction and more than ten times as much in the other direction. If any diode shows low or high in both directions, the diode is defective and the junction box must be replaced.

### NOTE

○The actual meter reading varies with the meter used and the individual diodes, but, generally speaking, the lower reading should be from zero to one half the scale.

Junction Box Internal Circuit (US, Canada, and Australia)

EC49

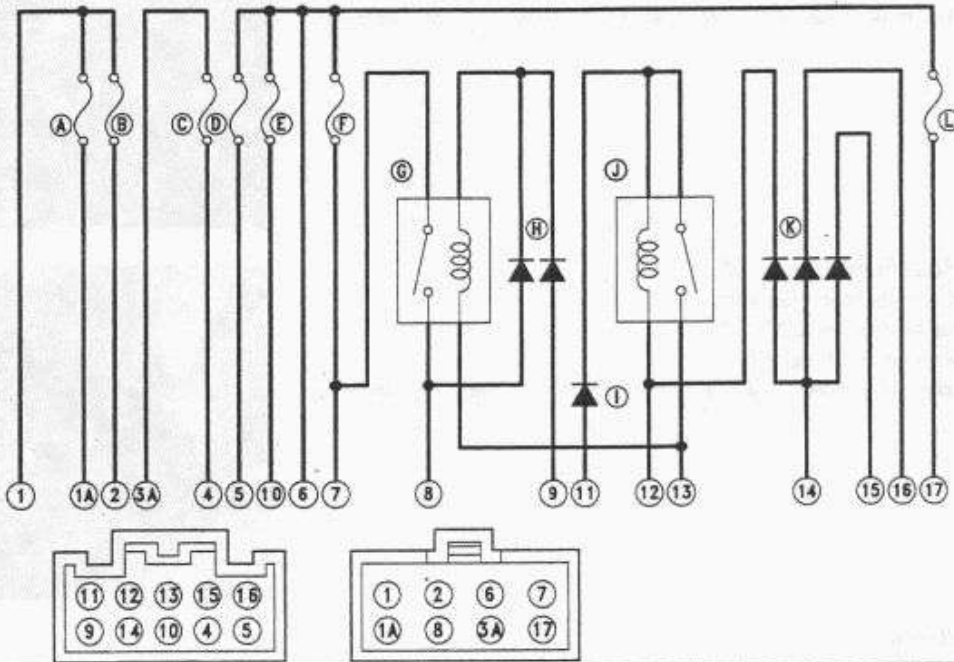

Junction Box Internal Circuit (Other than US, Canada, and Australia)

EC54

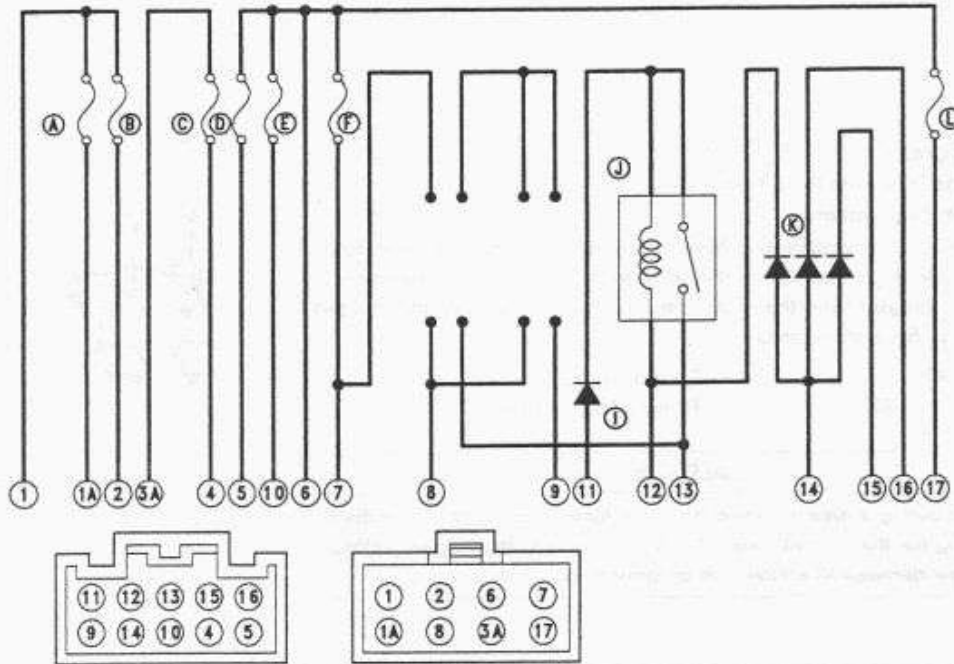

- A. Accessory Fuse 10A
- B. Fan Fuse 10A
- C. Turn Signal Fuse 10A
- D. Horn Fuse 10A

- E. Ignition Fuse 10A
- F. Headlight Fuse 10A
- G. Headlight Relay
- H. Headlight Diodes

- I. Starter Diode
- J. Starter Circuit Relay
- K. Interlock Diodes
- L. Taillight Fuse 10A

## Fuse

### 30A Main Fuse Removal

- Remove:
  - Seats (See Frame chapter)
  - Starter Relay and 30A Main Fuse Connector [A]
- Pull out the main fuse [B] from the starter relay with needle nose pliers.

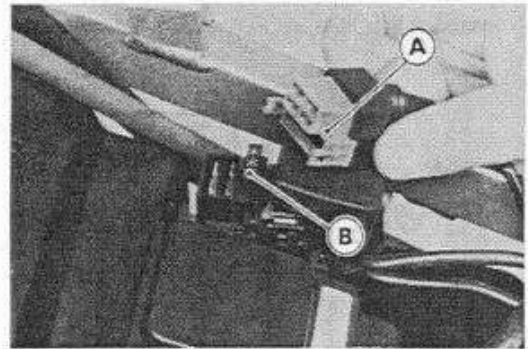

### Junction Box Fuse Removal

- Remove the seats (see Frame chapter).
- Remove the seat cover (ZX750N).
- Unlock the hook to lift up the lid [A].
- Pull the fuses [B] straight out of the junction box with needle nose pliers.

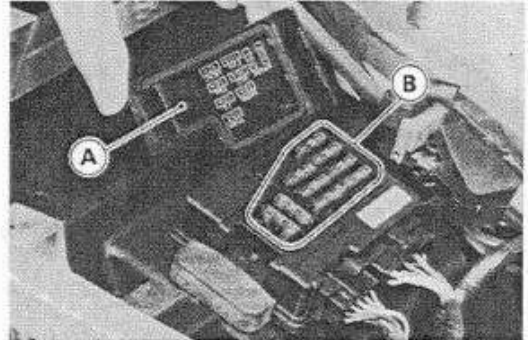

### Fuse Installation

- If a fuse fails during operation, inspect the electrical system to determine the cause, and then replace it with a new fuse of proper amperage.
- Install the junction box fuses on the original position as specified on the lid.

### Fuse Inspection

- Remove the fuse (see Fuse Removal).
- Inspect the fuse element.
- ★ If it is blown out, replace the fuse. Before replacing a blown fuse, always check the amperage in the affected circuit. If the amperage is equal to or greater than the fuse rating, check the wiring and related components for a short circuit.

Housing [A]  
Fuse Element [B]

Terminals [C]  
Blown Element [D]

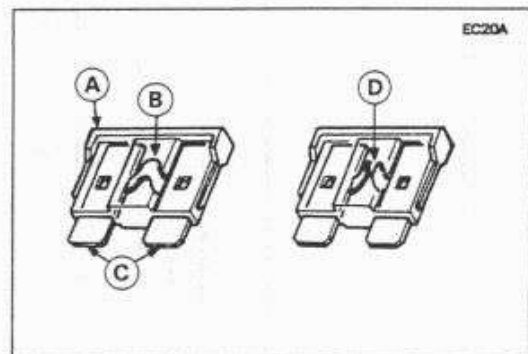

### CAUTION

When replacing a fuse, be sure the new fuse matches the specified fuse rating for that circuit. Installation of a fuse with a higher rating may cause damage to wiring and components.



Wiring Diagram  
1965-1966  
1967-1968

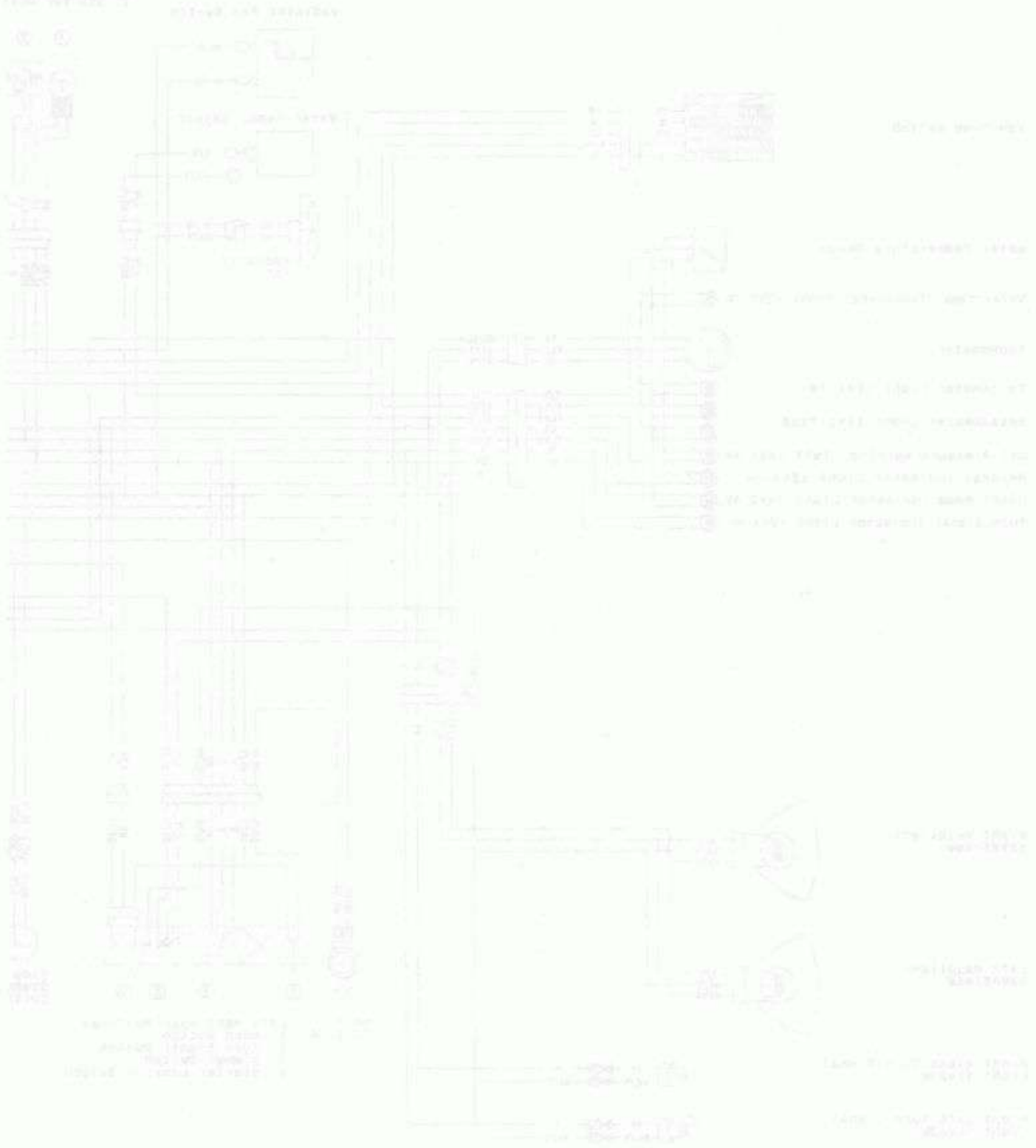

Component	Part Number	Notes
Battery	31-1000	12V, 60Ah
Fuse Block	31-1001	10 Amp Fuses
Headlight Switch	31-1002	3-Position
Horn	31-1003	12V, 10W
Headlight	31-1004	55W/60V
Headlight	31-1005	55W/60V

# ZX750N Wiring Diagram (US and Canada)

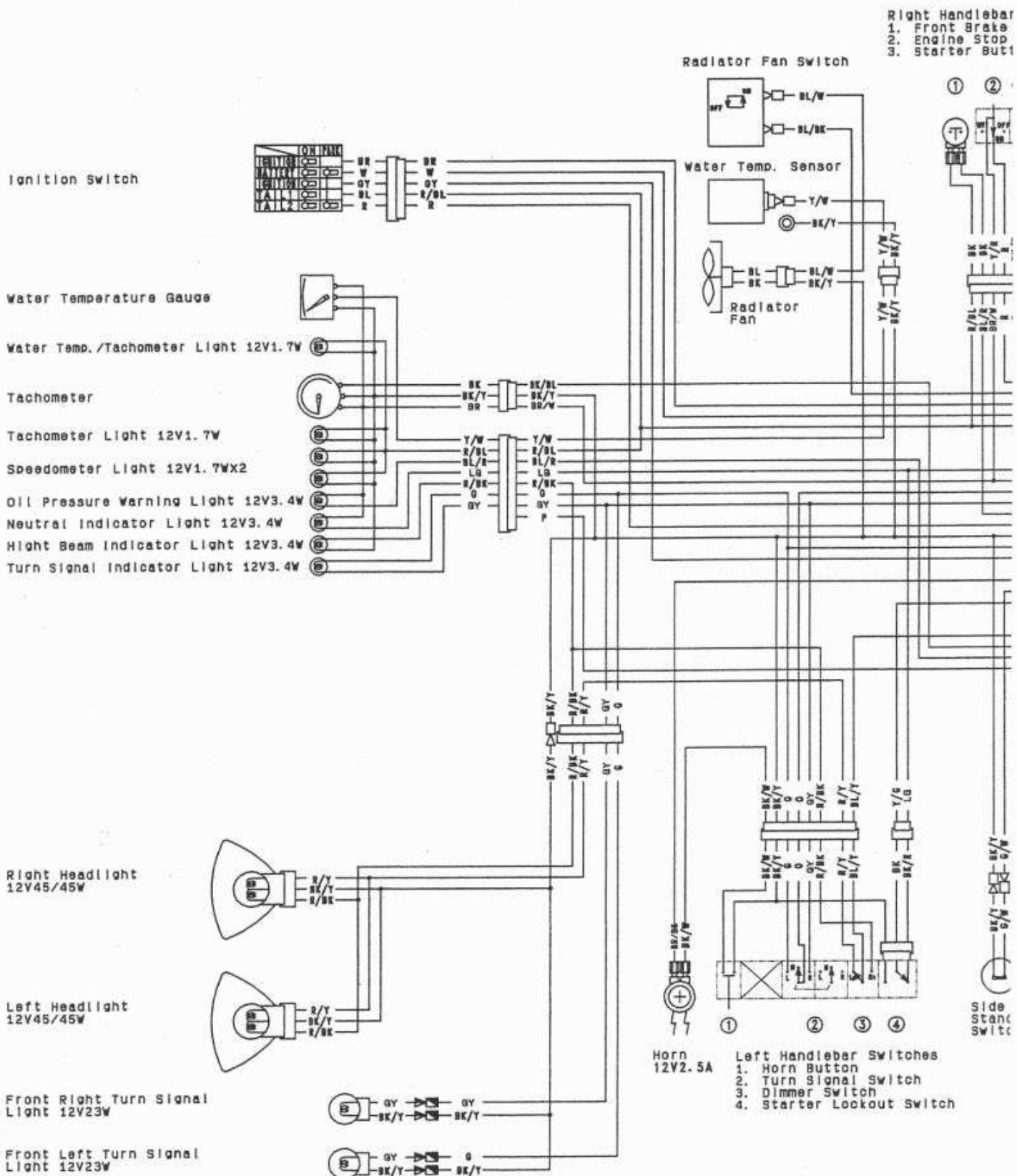

LEFT HANDLEBAR SWITCH CONNECTIONS										
	Horn Button		Turn Signal Switch		Dimmer Switch		Starter Lockout Sw			
	Color	BK/WBK/Y	Color	G	O	GY	Color	R/Y/BL/YR/BK	Color	BK/Y BK
Push	ON/OFF		R	ON/OFF			LO	ON/OFF	clutch Lever	
Released			OFF(PUSH)						Released	ON/OFF
			L	ON/OFF			HI	ON/OFF	Pulled in	ON/OFF

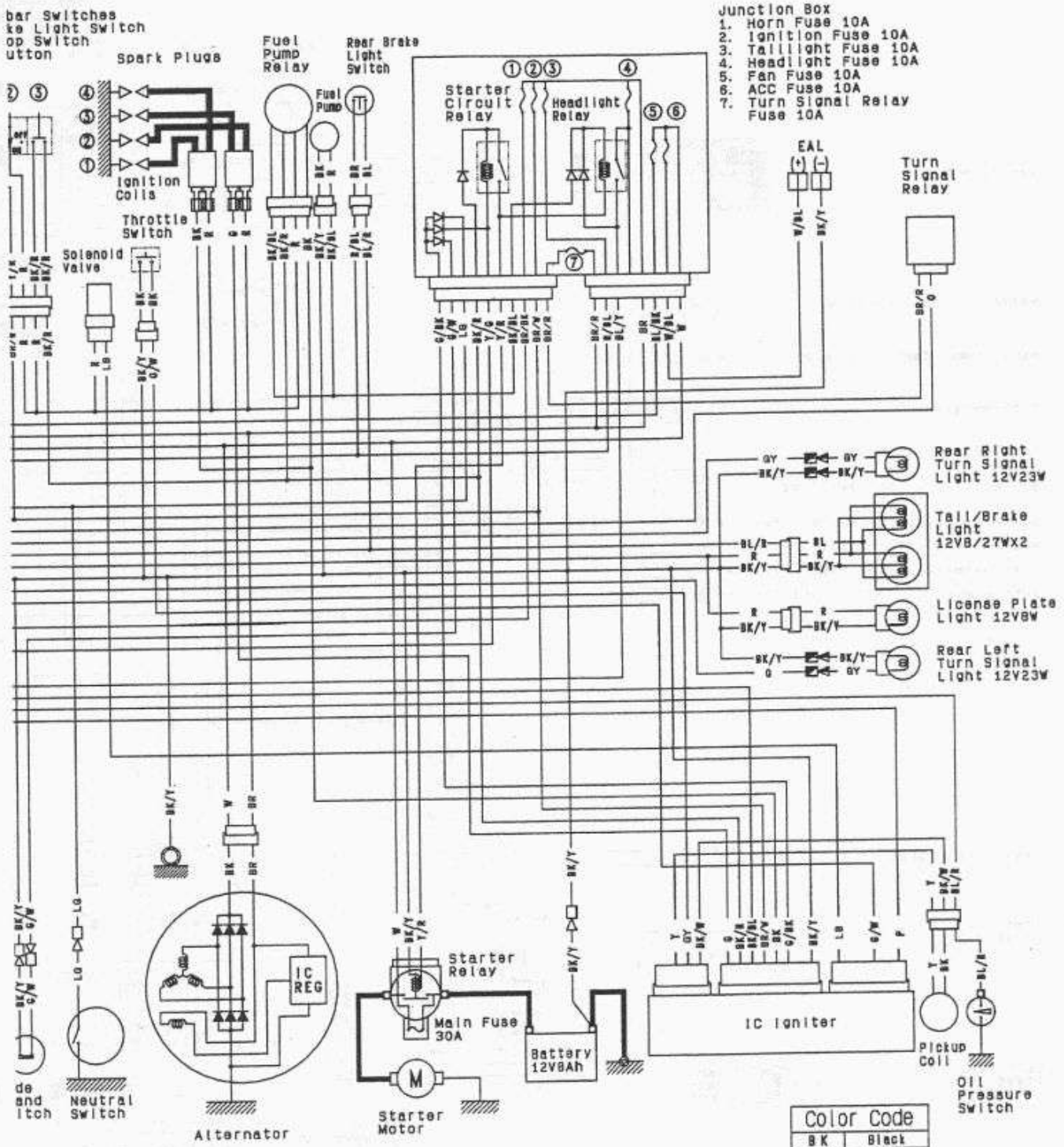

- Junction Box
1. Horn Fuse 10A
  2. Ignition Fuse 10A
  3. Taillight Fuse 10A
  4. Headlight Fuse 10A
  5. Fan Fuse 10A
  6. ACC Fuse 10A
  7. Turn Signal Relay Fuse 10A

EAL: Electrical Accessory Leads

Color Code	
BK	Black
BL	Blue
BR	Brown
CH	Chocolate
DG	Dark Green
G	Green
GY	Gray
LB	Light Blue
LG	Light Green
O	Orange
P	Pink
P U	Purple
R	Red
W	White
Y	Yellow

Switch	IGNITION SWITCH CONNECTIONS				
	Ignition	Battery	Ignition	Tails	Tail 2
Color	BK	W	GY	BL	R
OFF, LOCK	○	○	○	○	○
ON	○	○	○	○	○
P(PARK)	○	○	○	○	○

RIGHT HANDLEBAR SWITCH CONNECTIONS				
Front Brake Light Switch	Engine Stop Switch		Starter Button	
Color	BK	BK	Y/R	R
Brake Lever	○	○	○	○
Pulled In	○	○	○	○
Released	○	○	○	○
Color	BK/R	BK/R		
Push	○	○		
Released	○	○		

(98051-1581B)C

# 15-54 ELECTRICAL SYSTEM

## ZX750N Wiring Diagram (United Kingdom)

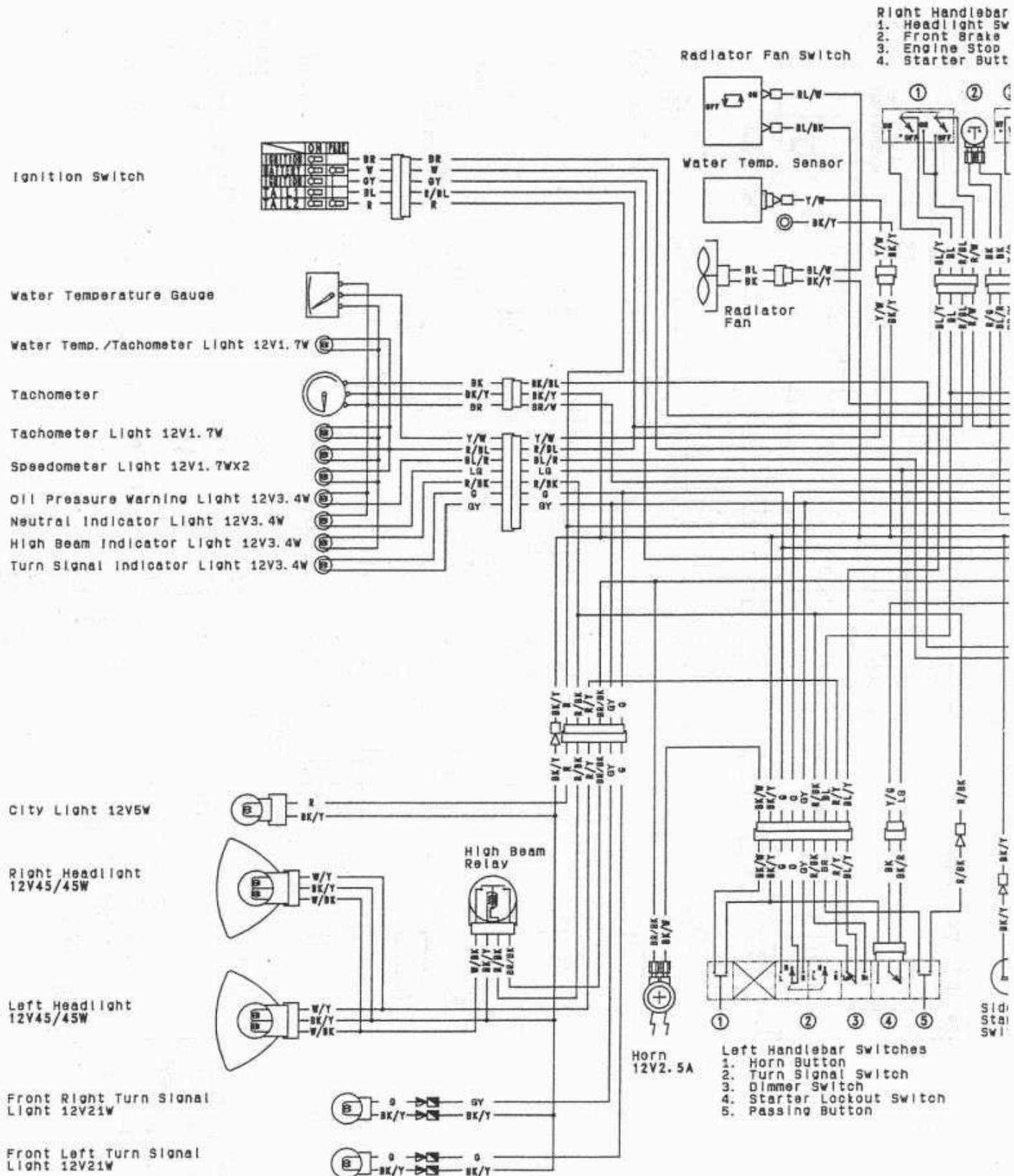

LEFT HANDLEBAR SWITCH CONNECTIONS								
Horn Button	Turn Signal Switch	Dimmer Switch	Starter Lockout Switch	Passing Button				
Color	BK/WBK/Y	Color	G O GY	Color	R/Y BL/YR/BK	Color	BK/Y BK BK/R	
Push	○	R	○	LO	○	Clutch Lever	Push	○
Released	○	OFF(Push)	○	HI	○	Released	Released	○
		L	○		○	Pulled in		○

IGNITION SWITCH	
Color	BR W
OFF. LOCK	○
ON	○
P(PARK)	○

Handlebar Switches  
 Light Switch  
 Front Brake Light Switch  
 Engine Stop Switch  
 Starter Button

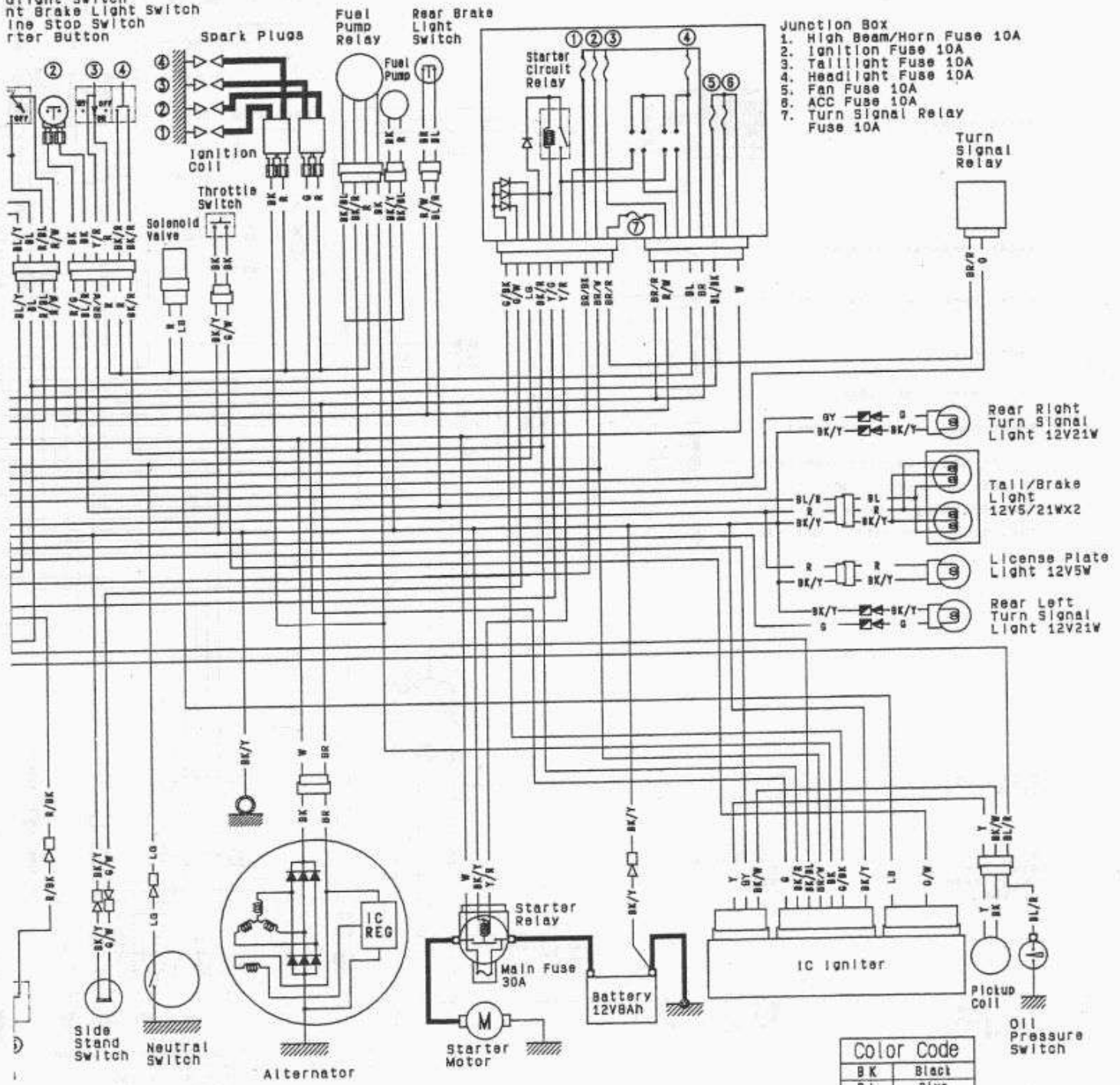

- Junction Box
1. High Beam/Horn Fuse 10A
  2. Ignition Fuse 10A
  3. Taillight Fuse 10A
  4. Headlight Fuse 10A
  5. Fan Fuse 10A
  6. ACC Fuse 10A
  7. Turn Signal Relay Fuse 10A

Color Code	
BK	Black
BL	Blue
BR	Brown
CH	Chocolate
DG	Dark Green
G	Green
GY	Gray
LB	Light Blue
LG	Light Green
O	Orange
P	Pink
PU	Purple
R	Red
W	White
Y	Yellow

ON SWITCH CONNECTIONS				
Ignition	Battery	Ignition	Tails	Tail 2
BR	W	GY	BL	R

RIGHT HANDLEBAR SWITCH CONNECTIONS													
Headlight Switch		Front Brake Light Switch		Engine Stop Switch		Starter Button							
Color	BL/Y	BL	R/BL	R/W	Color	BK	BK	Color	Y/R	R	Color	BK/R	BK/R
OFF					Brake Lever			OFF			Push		
					Pulled in						Released		
ON					Released			RUN					

(98051-1611A)C

# ZX750N Wiring Diagram (European Models except United Kingdom)

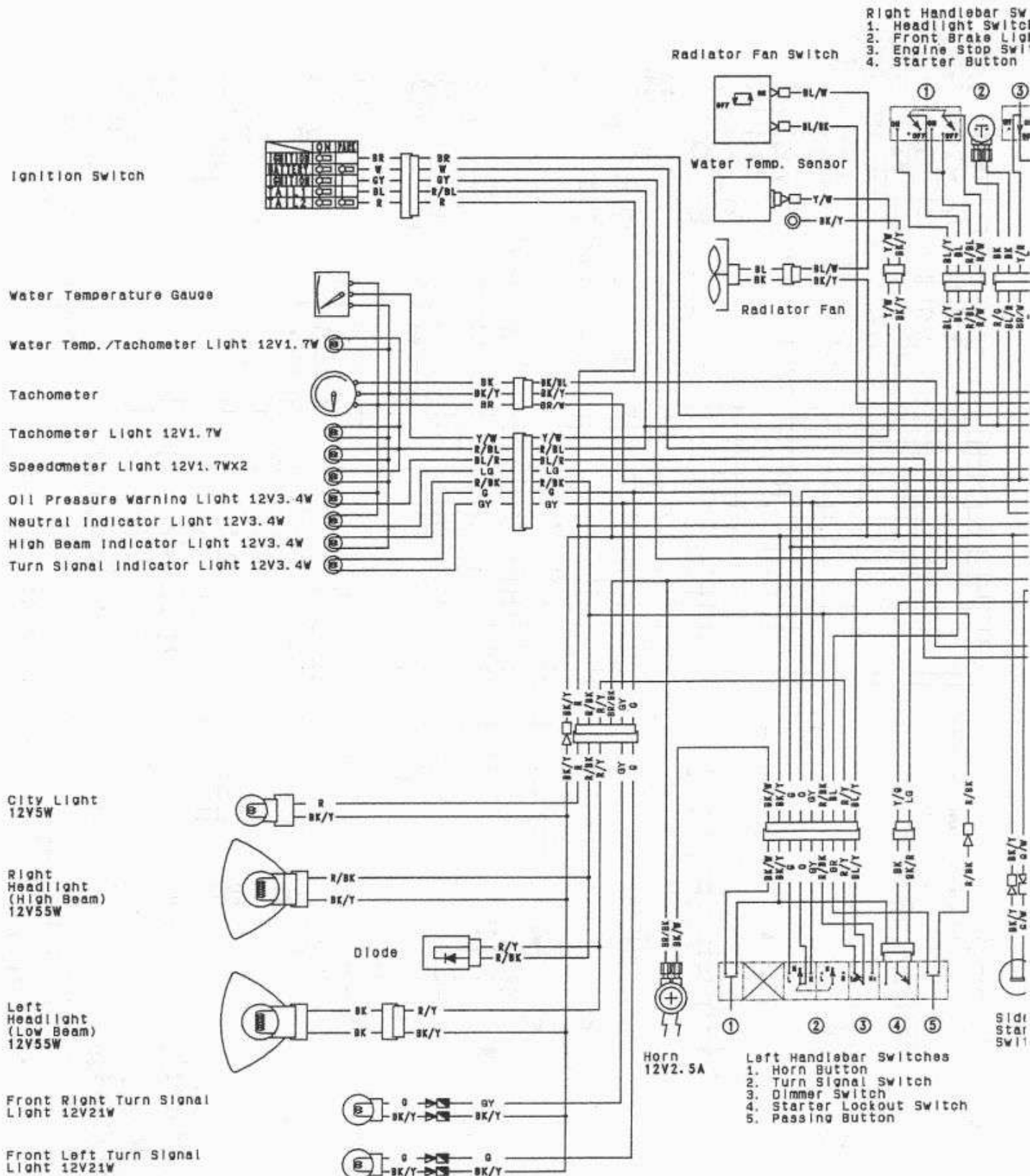

LEFT HANDLEBAR SWITCH CONNECTIONS									
Horn Button	Turn Signal Switch	Dimmer Switch			Starter Lockout Switch			Passing Button	
Color BK/WBK/Y	Color R	G	O	GY	Color R/Y	BL/YR/BK	Color BK/Y	BK	BK/R
Push <input type="checkbox"/>	<input type="checkbox"/>	<input type="checkbox"/>	<input type="checkbox"/>	LO	<input type="checkbox"/>	Clutch Lever	<input type="checkbox"/>	Push	<input type="checkbox"/>
Released	OFF (Push)	<input type="checkbox"/>	<input type="checkbox"/>	HI	<input type="checkbox"/>	Released	<input type="checkbox"/>	Released	<input type="checkbox"/>
	L	<input type="checkbox"/>	<input type="checkbox"/>		<input type="checkbox"/>	Pulled in	<input type="checkbox"/>		

IGNITION SWITCH		
Color	BR	W
OFF, LOCK	<input type="checkbox"/>	<input type="checkbox"/>
ON	<input type="checkbox"/>	<input type="checkbox"/>
P (PARK)	<input type="checkbox"/>	<input type="checkbox"/>

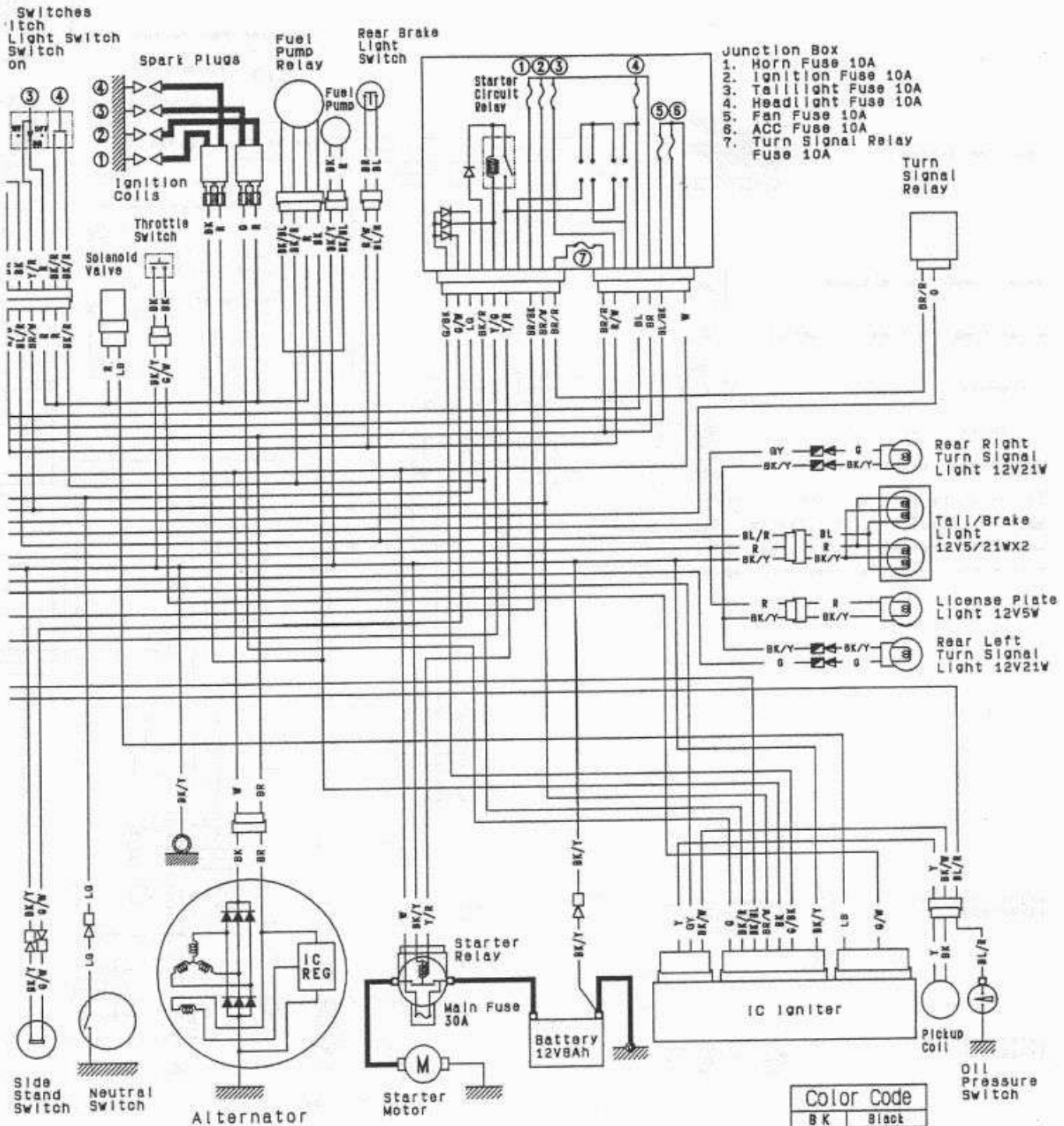

TCH CONNECTIONS			
Terminal	Ignition	Tail	Tail 2
#	GY	BL	R
1			
2			
3			
4			
5			
6			
7			

RIGHT HANDLEBAR SWITCH CONNECTIONS												
Headlight Switch		Front Brake Light Switch		Engine Stop Switch		Starter Button						
Color	BL/Y	BL	R/BL/R/W	Color	BK	BK	Color	Y/R	R	Color	BK/R	BK/R
OFF				Brake Lever			OFF			Push		
●				Pulled in			●			Released		
○				Released			○					
ON							ON					

Color Code	
BK	Black
BL	Blue
BR	Brown
CH	Chocolate
DG	Dart Green
G	Green
GY	Gray
LB	Light Blue
LG	Light Green
O	Orange
P	Pink
PU	Purple
R	Red
W	White
Y	Yellow

(98051-15798)C

# ZX750P Wiring Diagram (US and Canada)

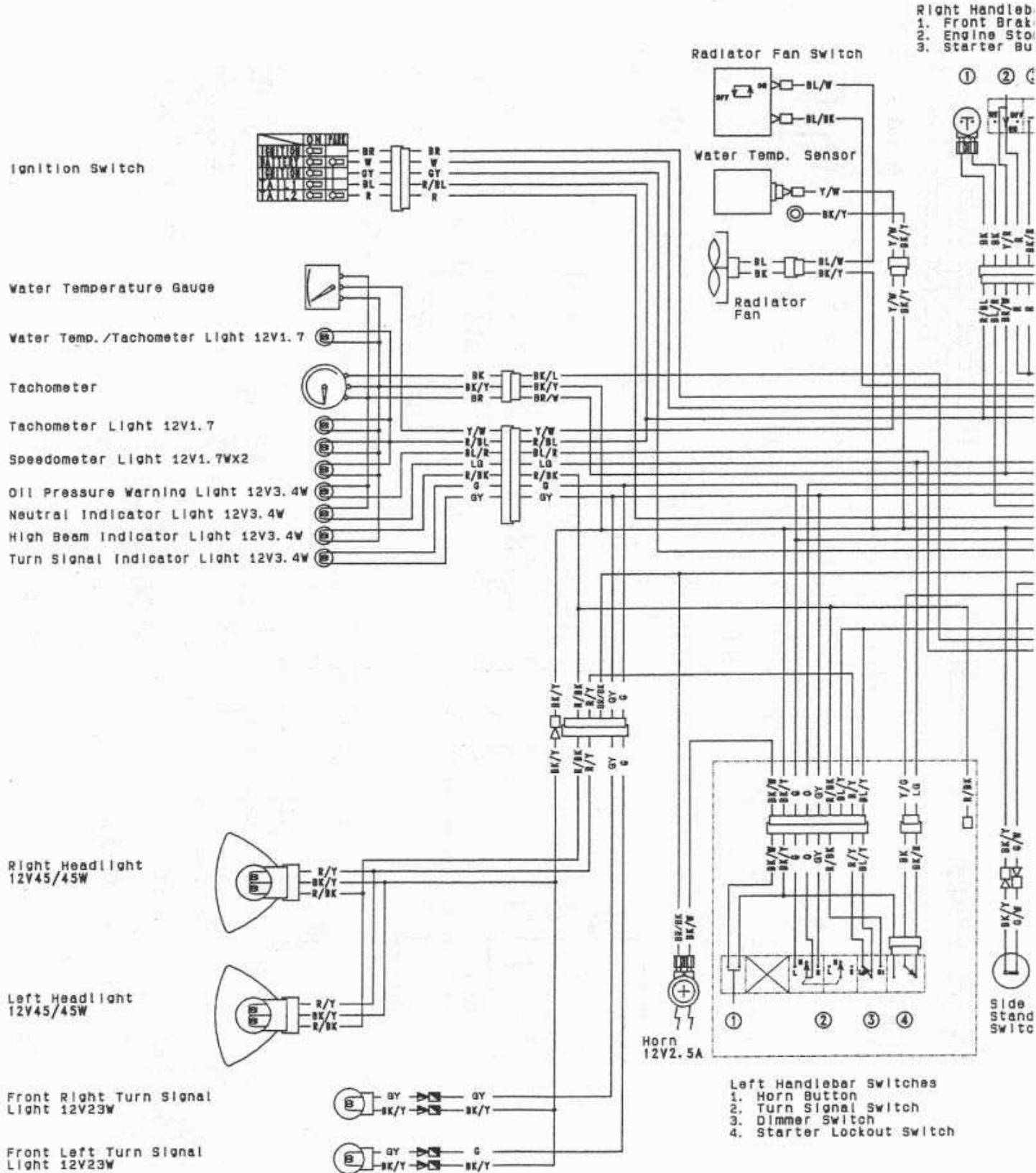

LEFT HANDLEBAR SWITCH CONNECTIONS									
Horn Button	Turn Signal Switch	Dimmer Switch		Starter Lockout Switch					
Color	BK/WBK/Y	Color	G	O	GY	Color	R/Y/BL/YR/BK	Color	BK/Y BK BK/R
Push	<input type="checkbox"/>	R	<input type="checkbox"/>	<input type="checkbox"/>	LO	<input type="checkbox"/>		Clutch Lever	
Released		OFF (Push)	<input type="checkbox"/>		HI	<input type="checkbox"/>		Released	<input type="checkbox"/>
		L	<input type="checkbox"/>					Pulled In	<input type="checkbox"/>

IGN
Coil
OFF, L
O
P (PA)



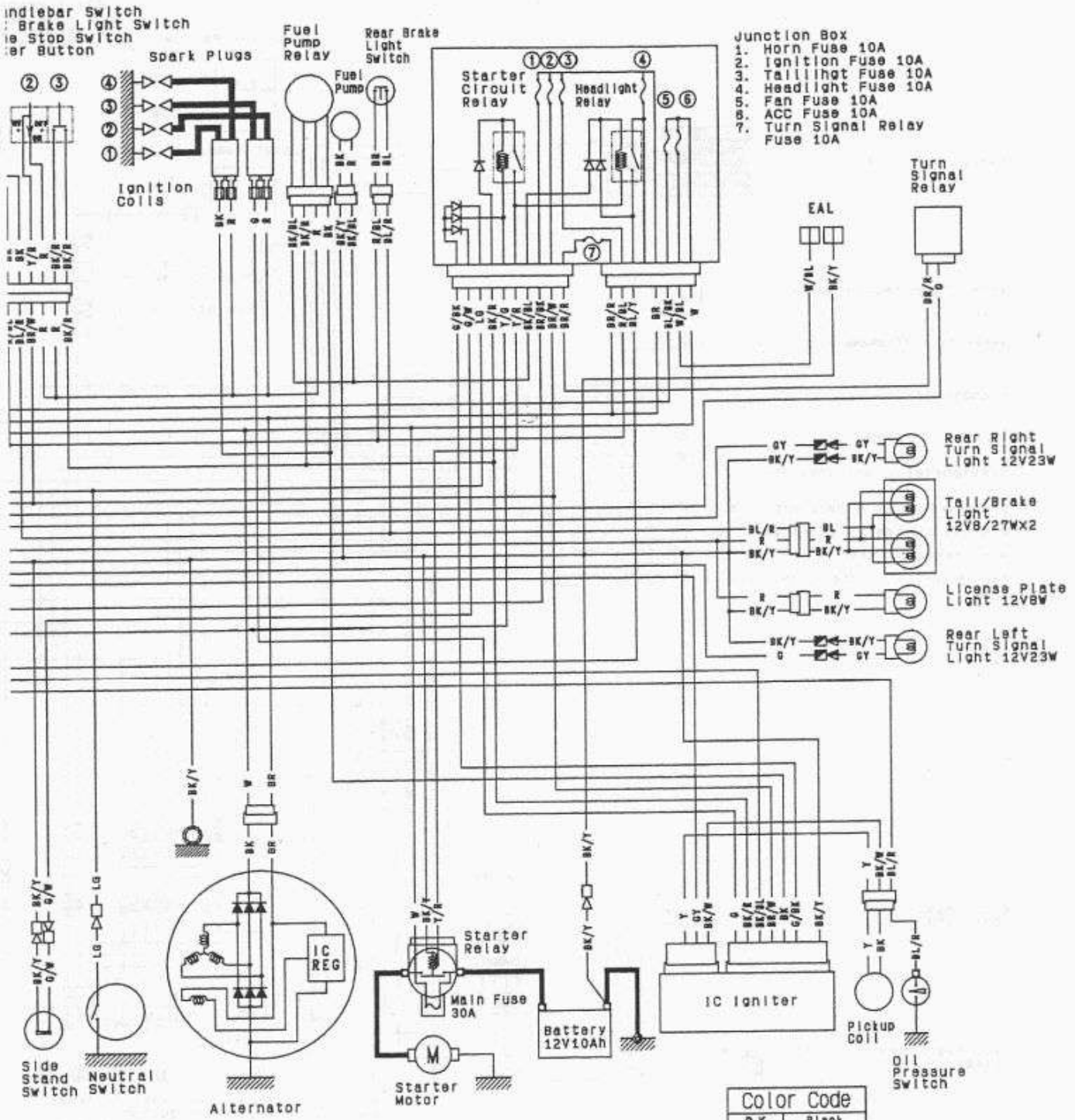

EAL: Electrical Accessory Leads

Color Code	
BK	Black
BL	Blue
BR	Brown
CH	Chocolate
DG	Dart Green
G	Green
GY	Gray
LB	Light Blue
LG	Light Green
O	Orange
P	Pink
PU	Purple
R	Red
W	White
Y	Yellow

IGNITION SWITCH CONNECTIONS					
	Ignition	Battery	Ignition	Tail 1	Tail 2
Color	BR	W	GY	BL	R
OFF, LOCK	○	○	○	○	○
ON	○	○	○	○	○
P (PARK)	○	○	○	○	○

RIGHT HANDLEBAR SWITCH CONNECTIONS					
	Front Brake Light Switch		Engine Stop Switch		Starter Button
Color	BK	BK	Color	Y/R	R
Brake Lever	○	○	OFF	○	○
Pulled in	○	○			Released
Released			RUN	○	

(98051-1582B)C

# 15-58 ELECTRICAL SYSTEM

## ZX750P Wiring Diagram (Australia)

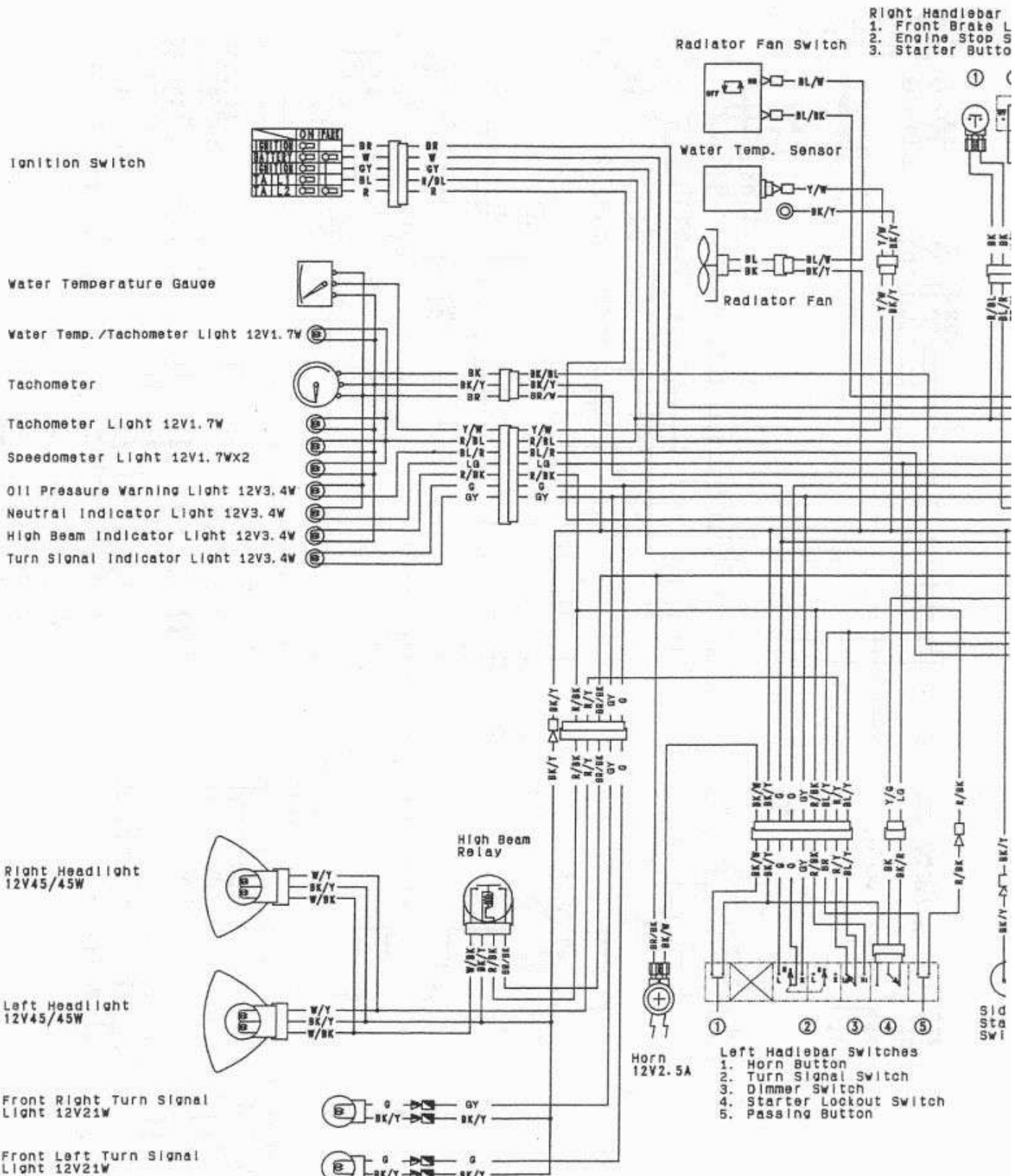

LEFT HANDLEBAR SWITCH CONNECTIONS												
Horn Button	Turn Signal Switch	Dimmer Switch	Starter Lockout Switch	Passing Bl								
Color	BK/WBK/Y	Color	G	O	GY	Color	R/Y/BL/YR/BK	Color	BK/Y	BK/R	Color	BR
Push	ON/OFF	R	ON/OFF	LO	ON/OFF	Clutch Lever			Push	ON		
Released	OFF(Push)	L	ON/OFF	HI	ON/OFF	Released			Released			
						Pulled in						

Right Handlebar Switches  
 Front Brake Light Switch  
 Engine Stop Switch  
 Starter Button

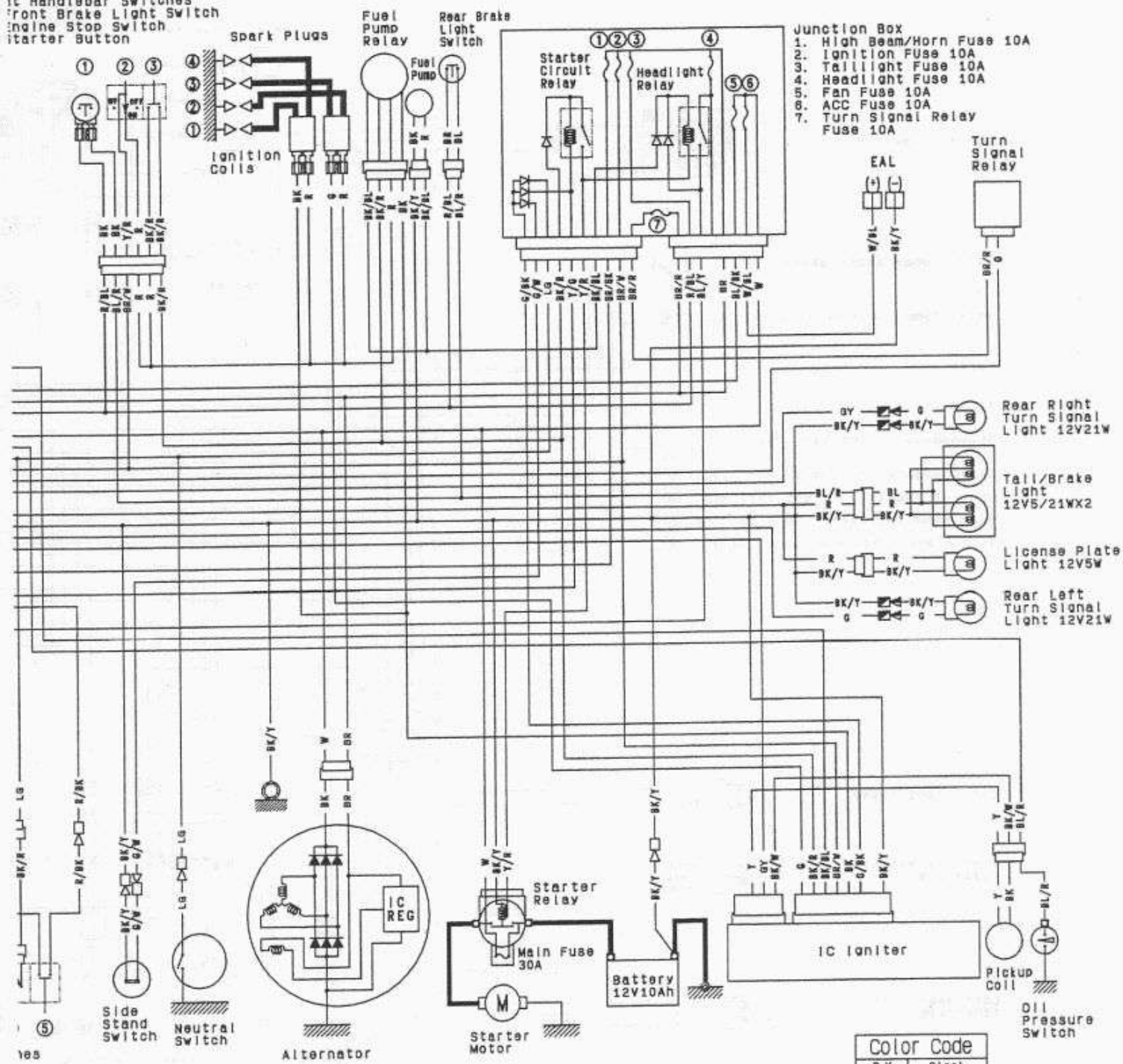

EAL: Electrical Accessory Leads

Ignition Switch Position	Color	Wiring
OFF, LOCK	BK	Ignition
ON	W	Battery
P(PARK)	GY	Ignition

Ignition Switch Position	Color	Wiring
OFF, LOCK	BK	Taillight
ON	W	Battery
P(PARK)	GY	Taillight

Front Brake Light Switch	Engine Stop Switch	Starter Button
Color BK BK	Color Y/R R	Color BK/R BK/R
Brake Lever Pulled in	OFF	Push
Released	RUN	Released

(98051-1610A)C

# ZX750P Wiring Diagram (United Kingdom)

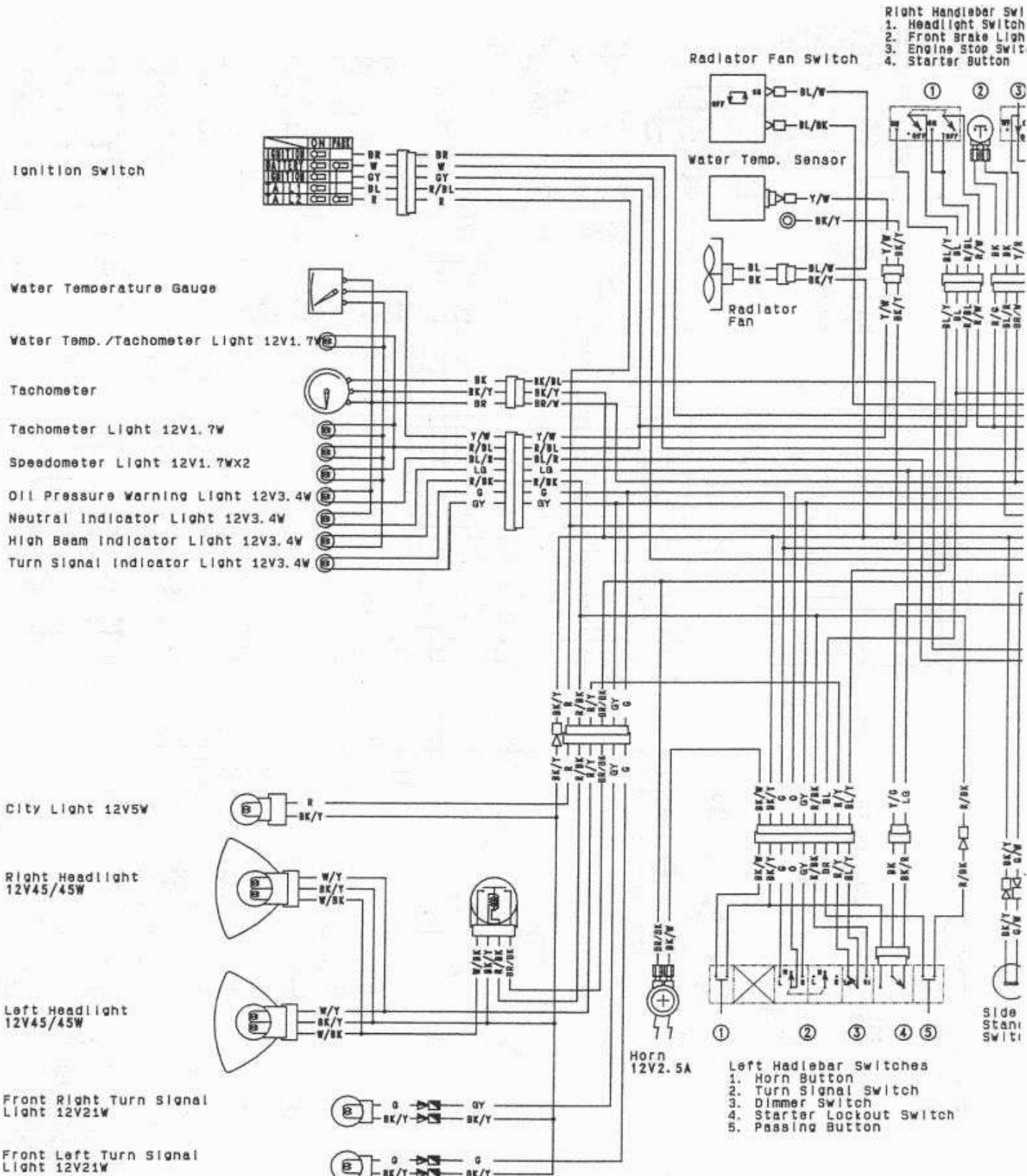

LEFT HANDLEBAR SWITCH CONNECTIONS															
Horn Button	Turn Signal Switch	Dimmer Switch			Starter Lockout Switch			Passing Button							
Color	BK/WBK/Y	Color	G	O	GY	Color	R/Y	BL/YR/BK	Color	BK/Y	BK	BK/R	Color	BR	R/BK
Push	<input type="checkbox"/>			<input type="checkbox"/>											
Released															
		L													

IGNITION SWITCH CONNECTIONS				
Color	BR	W	GY	BI
OFF, LOCK	<input type="checkbox"/>	<input type="checkbox"/>	<input type="checkbox"/>	<input type="checkbox"/>
ON	<input type="checkbox"/>	<input type="checkbox"/>	<input type="checkbox"/>	<input type="checkbox"/>
P(PARK)	<input type="checkbox"/>	<input type="checkbox"/>	<input type="checkbox"/>	<input type="checkbox"/>

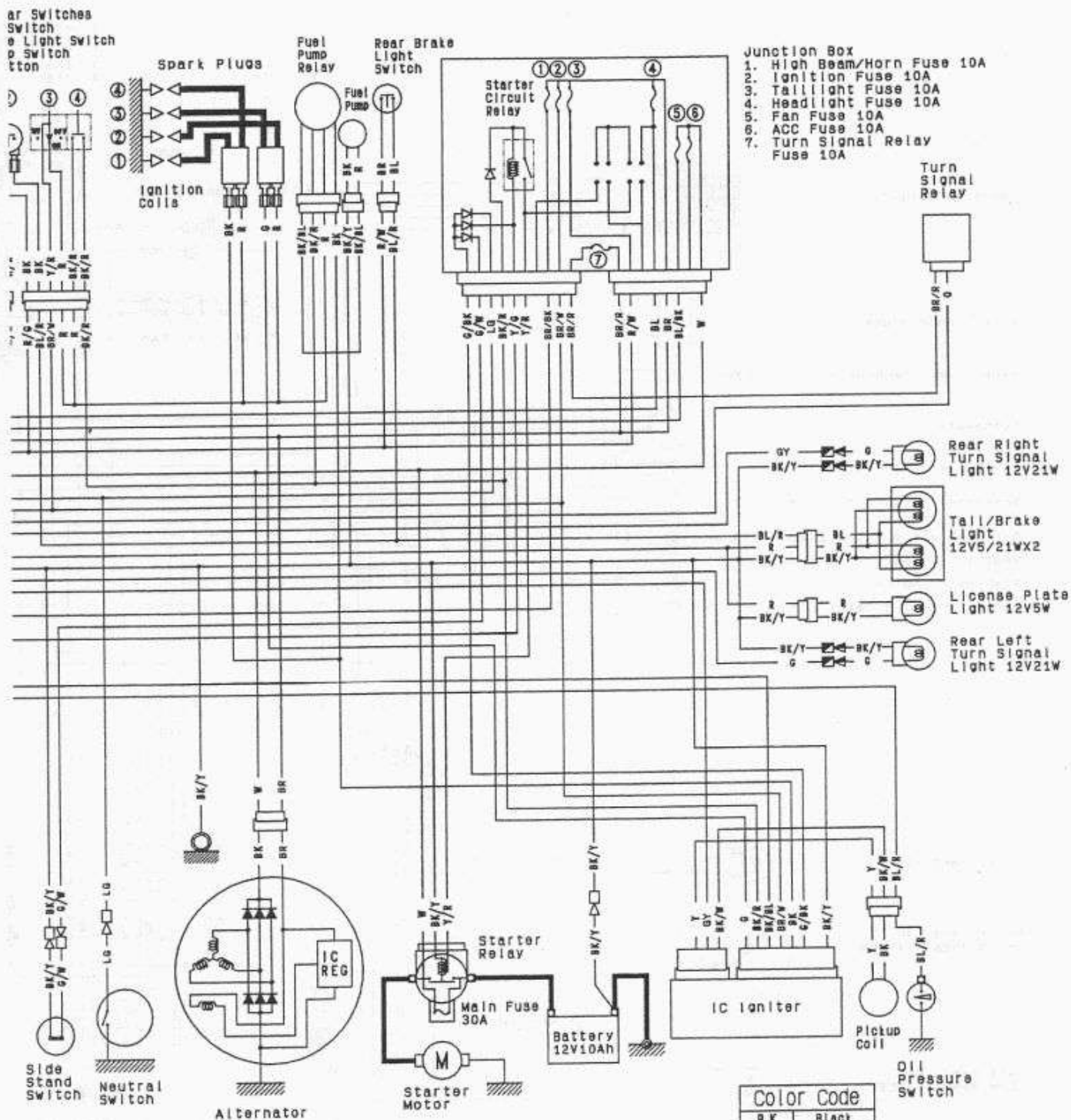

**CONNECTIONS**

Ignition Tail1	Tail2
Y	BL R

**RIGHT HANDLEBAR SWITCH CONNECTIONS**

Headlight Switch		Front Brake Light Switch		Engine Stop Switch		Starter Button	
Color	BL/Y BL R/BL R/W	Color	BK BK	Color	Y/R R	Color	BK/R BK/R
OFF		Brake Lever		Pulled in		Push	
ON		Released		Released		Released	

**Color Code**

BK	Black
BL	Blue
BR	Brown
CH	Chocolate
DG	Dark Green
G	Green
GY	Gray
LB	Light Blue
LG	Light Green
O	Orange
P	Pink
PU	Purple
R	Red
W	White
Y	Yellow

(98051-1612A)

# 15-60 ELECTRICAL SYSTEM

## ZX750P Wiring Diagram (European Models except United Kingdom)

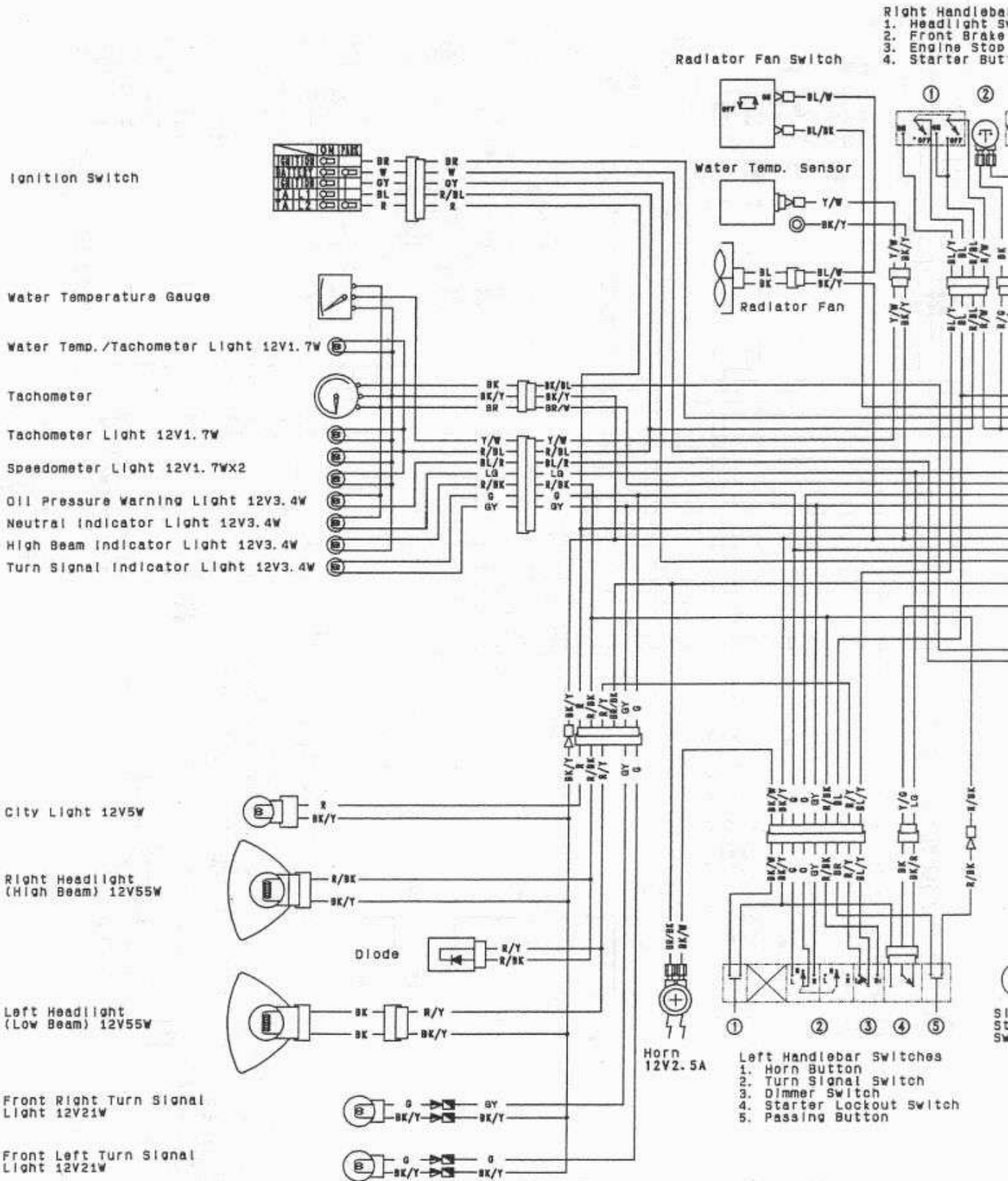

LEFT HANDLEBAR SWITCH CONNECTIONS										
Horn Button	Turn Signal Switch	Dimmer Switch			Starter Lockout Switch			Passing Button		
Color	BK/WBK/Y	Color	G	O	GY	Color	R/Y/BL/YR/BK	Color	BK/Y BK BK/R Color	BR R/BK
Push	○	R	○	○	○	LO	○	Clutch Lever	Push	○
Released		OFF(Push)				HI		Released	Released	○
		L	○				○	Pulled in	Released	○

IGNITION SWITCH		
Ignition/Battery		
Color	BR	W
OFF, LOCK		
ON	○	○
P (PARK)		○

Right Handbar Switches  
 Headlight Switch  
 Brake Light Switch  
 Engine Stop Switch  
 Starter Button

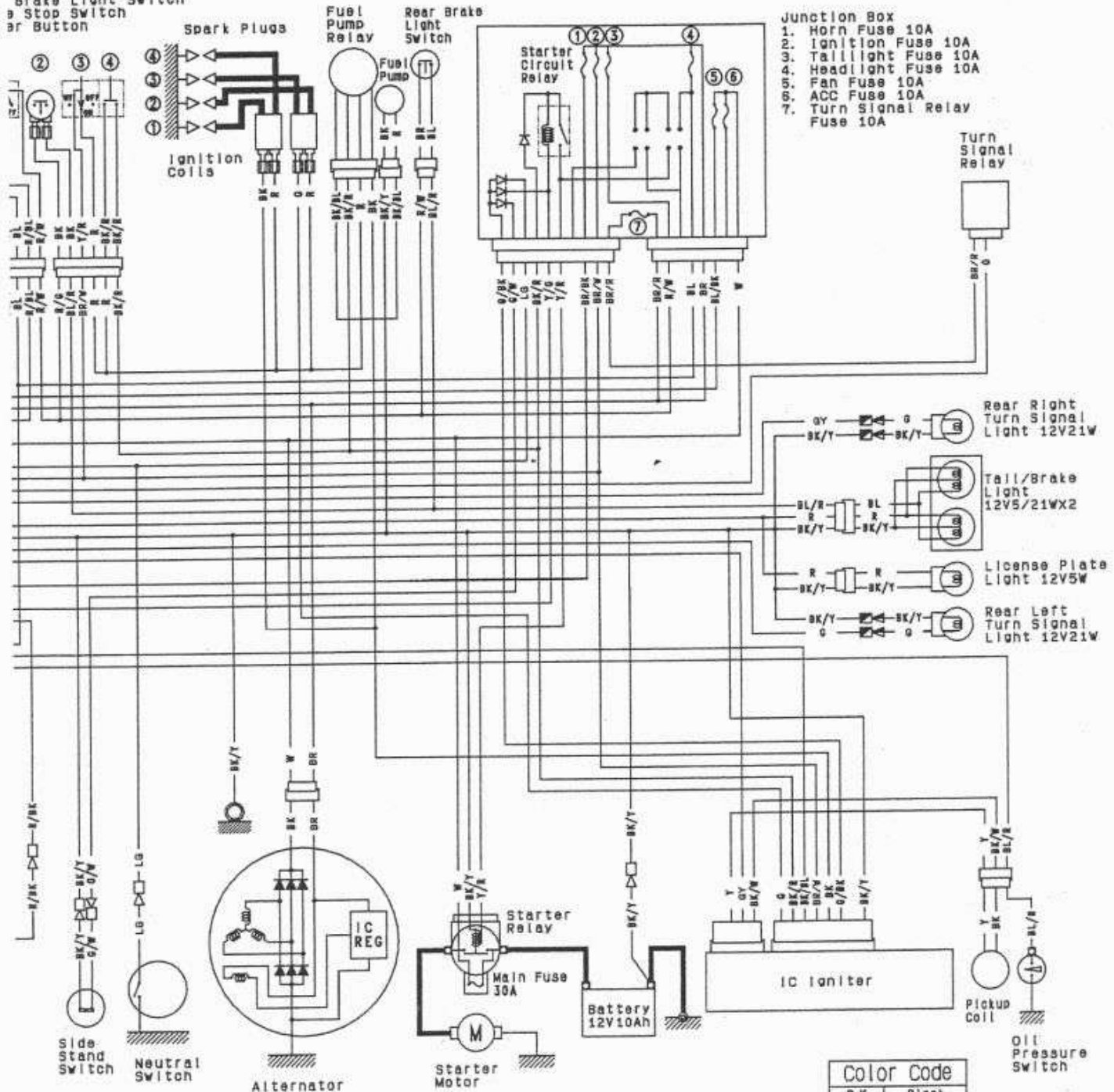

- Junction Box**
1. Horn Fuse 10A
  2. Ignition Fuse 10A
  3. Taillight Fuse 10A
  4. Headlight Fuse 10A
  5. Fan Fuse 10A
  6. ACC Fuse 10A
  7. Turn Signal Relay Fuse 10A

SWITCH CONNECTIONS			
on	Battery	Ignition	Tail
W	GY	BL	R

RIGHT HANDLEBAR SWITCH CONNECTIONS							
Headlight Switch		Front Brake Light Switch		Engine Stop Switch		Starter Button	
Color	BL/Y	BL	R/BL	R/W	Color	Y/R	R
OFF				Brake Lever	Color	Y/R	R
				Pulled In	Color	Y/R	R
ON				Released	Color	Y/R	R

Color Code	
BK	Black
BL	Blue
BR	Brown
CH	Chocolate
DG	Dark Green
G	Green
GY	Gray
LB	Light Blue
LG	Light Green
O	Orange
P	Pink
PU	Purple
R	Red
W	White
Y	Yellow

(98051-15809)

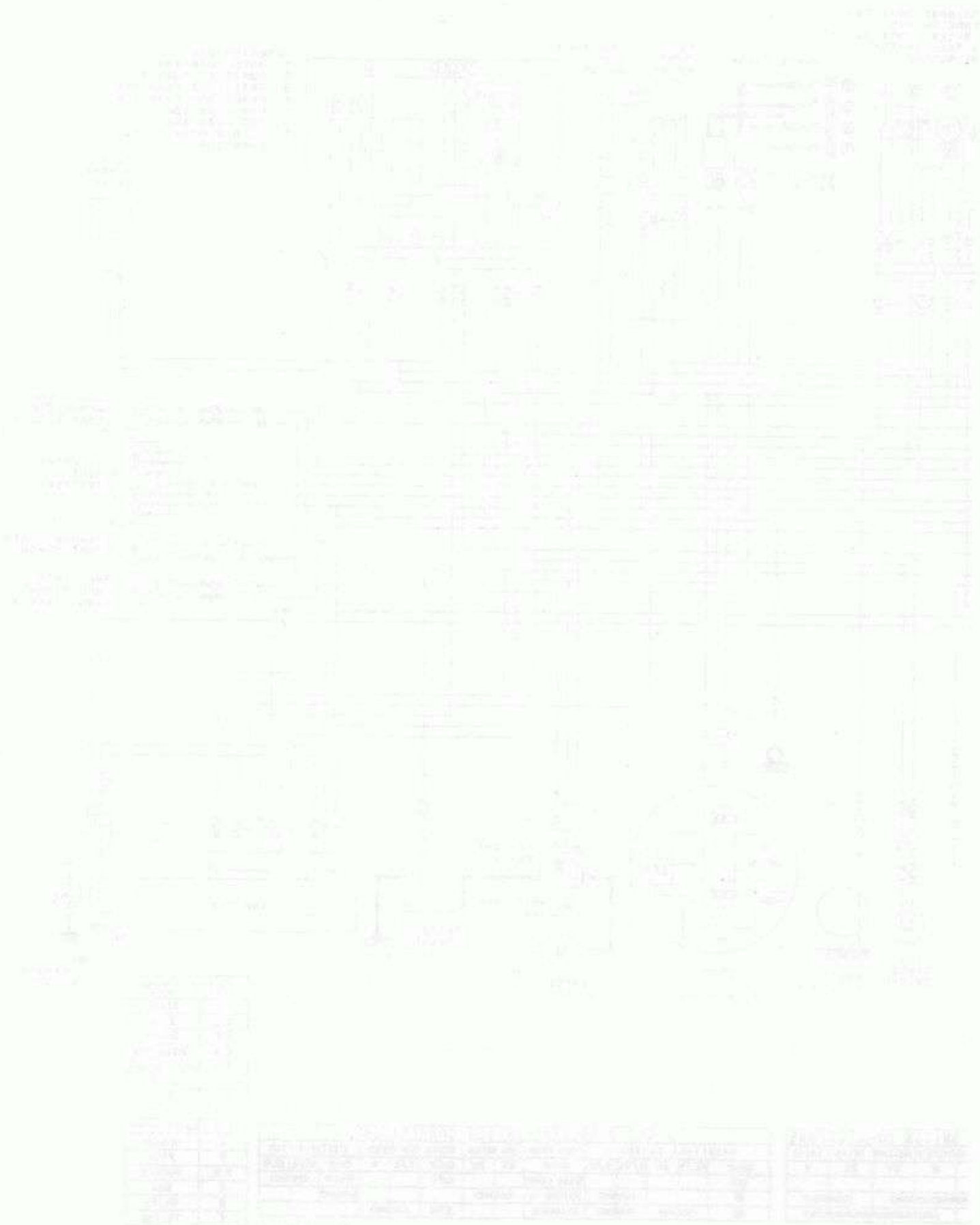



# Appendix

## Table of Contents

Additional Considerations for Racing .....	16-2
Carburetor .....	16-2
Spark Plug .....	16-2
Spark Plug Inspection .....	16-3
Troubleshooting Guide .....	16-4
General Lubrication .....	16-8
Lubrication .....	16-8
Nut, Bolt, and Fastener Tightness .....	16-9
Tightness Inspection .....	16-9
Unit Conversion Table .....	16-10



## Additional Considerations for Racing

This motorcycle has been manufactured for use in a reasonable and prudent manner and as a vehicle only. However, some may wish to subject this motorcycle to abnormal operation, such as would be experienced under racing conditions. **KAWASAKI STRONGLY RECOMMENDS THAT ALL RIDERS RIDE SAFELY AND OBEY ALL LAWS AND REGULATIONS CONCERNING THEIR MOTORCYCLE AND ITS OPERATION.**

Racing should be done under supervised conditions, and recognized sanctioning bodies should be contacted for further details. For those who desire to participate in competitive racing or related use, the following technical information may prove useful. However, please note the following important notes.

- You are entirely responsible for the use of your motorcycle under abnormal conditions such as racing, and Kawasaki shall not be liable for any damages which might arise from such use.
- Kawasaki's Limited Motorcycle Warranty and Limited Emission Control Systems Warranty specifically exclude motorcycles which are used in competition or related uses. Please read the warranty carefully.
- Motorcycle racing is a very sophisticated sport, subject to many variables. The following information is theoretical only, and Kawasaki shall not be liable for any damages which might arise from alterations utilizing this information.
- When the motorcycle is operated on public roads, it **must** be in its original state in order to ensure safety and compliance with applicable regulations.

### Carburetor:

Sometimes an alteration may be desirable for improved performance under special conditions when proper mixture is not obtained after the carburetor has been properly adjusted, and all parts cleaned and found to be functioning properly.

If the engine still exhibits symptoms of overly rich or lean carburetion after all maintenance and adjustments are correctly performed, the main jet can be replaced with a smaller or larger one. A smaller numbered jet gives a leaner mixture and a larger numbered jet a richer mixture.

### Spark Plug:

The spark plug ignites the fuel and air mixture in the combustion chamber. To do this effectively and at the proper time, the correct spark plug must be used, and the spark plug must be kept clean and the gap adjusted.

Tests have shown the plug listed in the "General Information" chapter to be the best plug for general use.

Since spark plug requirements change with the ignition and carburetion adjustments and with riding conditions, whether or not a spark plug of the correct heat range is used should be determined by removing and inspecting the plug.

- [A] Terminal
- [B] Insulator
- [C] Cement
- [D] Gasket
- [E] Center Electrode
- [F] Gap (0.7 ~ 0.8 mm)
- [G] Reach
- [H] Side Electrode

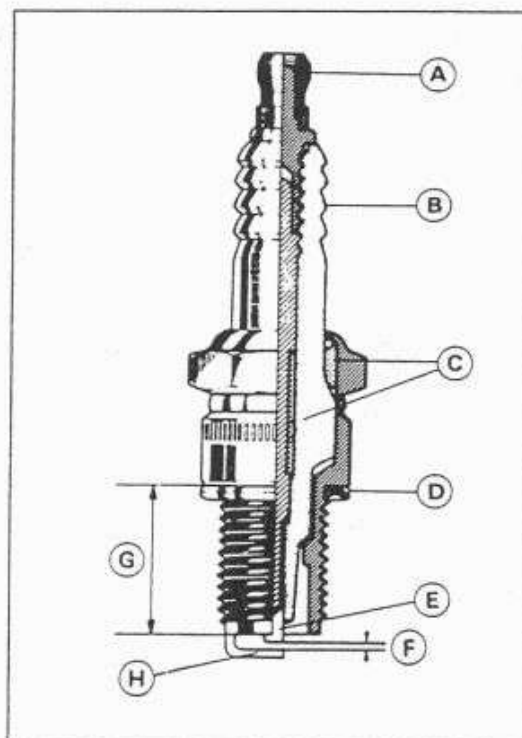

When a plug of the correct heat range is being used, the electrodes will stay hot enough to keep all the carbon burned off, but cool enough to keep from damaging the engine and the plug itself. This temperature is about 400 ~ 800°C (750 ~ 1,450°F) and can be judged by noting the condition and color of the ceramic insulator around the center electrode. If the ceramic is clean and of a light brown color, the plug is operating at the right temperature.

A spark plug for higher operating temperatures is used for racing. Such a plug is designed for better cooling efficiency so that it will not overheat and thus is often called a "colder" plug. If a spark plug with too high a heat range is used – that is, a "cold" plug that cools itself too well – the plug will stay too cool to burn off the carbon, and the carbon will collect on the electrodes and the ceramic insulator.

The carbon on the electrodes conducts electricity, and can short the center electrode to ground by either coating the ceramic insulator or bridging across the gap. Such a short will prevent an effective spark. Carbon build-up on the plug can also cause other troubles. It can heat up red-hot and cause preignition and knocking, which may eventually burn a hole in the top of the piston.

### Spark Plug Inspection

- Remove the spark plug and inspect the ceramic insulator.
- ★ Whether or not the right temperature plug is being used can be ascertained by noting the condition of the ceramic insulator around the electrode. A light brown color indicates the correct plug is being used. If the ceramic is black, it indicates that the plug is firing at too low a temperature, so the next hotter type should be used instead. If the ceramic is white, the plug is operating at too high a temperature and it should be replaced with the next colder type.

#### CAUTION

If the spark plug is replaced with a type other than the standard plug, make certain the replacement plug has the same thread pitch and reach (length of threaded portion) and the same insulator type (regular type or projected type) as the standard plug.

If the plug reach is too short, carbon will build up on the plug hole threads in the cylinder head, causing overheating and making it very difficult to insert the correct spark plug later.

If the reach is too long, carbon will build up on the exposed spark plug threads causing overheating, preignition, and possibly burning a hole in the piston top. In addition, it may be impossible to remove the plug without damaging the cylinder head.

#### Standard Spark Plug Threads

Diameter:	10 mm
Pitch:	1.0 mm
Reach:	19 mm

#### NOTE

- The heat range of the spark plug functions like a thermostat for the engine. Using the wrong type of spark plug can make the engine run too hot (resulting in engine damage) or too cold (with poor performance, misfiring, and stalling).

### Spark Plug Condition



Carbon fouling



Oil fouling



Normal operation



Overheating

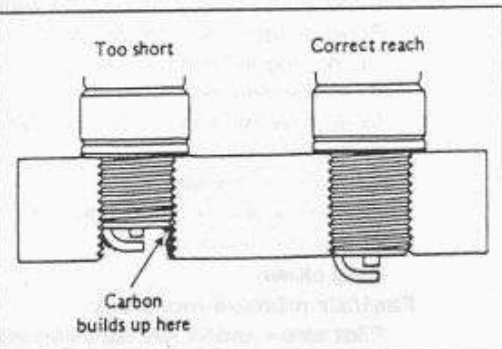

## Troubleshooting Guide

### NOTE

○ *This is not an exhaustive list, giving every possible cause for each problem listed. It is meant simply as a rough guide to assist the troubleshooting for some of the more common difficulties.*

### Engine Doesn't Start, Starting Difficulty:

#### Starter motor not rotating:

- Starter lockout or neutral switch trouble
- Starter motor trouble
- Battery voltage low
- Starter relays not contacting or operating
- Starter button not contacting
- Wiring open or shorted
- Ignition switch trouble
- Engine stop switch trouble
- Fuse blown

#### Starter motor rotating but engine doesn't turn over:

- Starter clutch trouble

#### Engine won't turn over:

- Valve seizure
- Valve lifter seizure
- Cylinder, piston seizure
- Crankshaft seizure
- Connecting rod small end seizure
- Connecting rod big end seizure
- Transmission gear or bearing seizure
- Camshaft seizure
- Alternator shaft bearing seizure

#### No fuel flow:

- No fuel in tank
- Battery voltage low
- Fuel pump trouble
- Fuel pump relay trouble
- Fuel tank air vent obstructed
- Fuel filter clogged
- Fuel tap clogged
- Fuel line clogged
- Float valve clogged

#### Engine flooded:

- Fuel level in carburetor float bowl too high
- Float valve worn or stuck open
- Starting technique faulty  
(When flooded, crank the engine with the throttle fully opened to allow more air to reach the engine.)

#### No spark; spark weak:

- Battery voltage low
- Spark plug dirty, broken, or maladjusted
- Spark plug cap or high tension wiring trouble
- Spark plug cap shorted or not in good contact
- Spark plug incorrect
- IC igniter trouble
- Neutral, starter lockout, or side stand switch trouble
- Pickup coil trouble
- Ignition coil trouble
- Ignition or engine stop switch shorted
- Wiring shorted or open
- Fuse blown

#### Fuel/air mixture incorrect:

- Pilot screw and/or idle adjusting screw maladjusted
- Pilot jet, or air passage clogged

- Air cleaner clogged, poorly sealed, or missing

- Starter jet clogged

#### Compression Low:

- Spark plug loose
- Cylinder head not sufficiently tightened down
- No valve clearance
- Cylinder, piston worn
- Piston ring bad (worn, weak, broken, or sticking)
- Piston ring/groove clearance excessive
- Cylinder head gasket damaged
- Cylinder head warped
- Valve spring broken or weak
- Valve not seating properly (valve bent, worn, or carbon accumulation on the seating surface)

### Poor Running at Low Speed:

#### Spark weak:

- Battery voltage low
- Spark plug dirty, broken, or maladjusted
- Spark plug cap or high tension wiring trouble
- Spark plug cap shorted or not in good contact
- Spark plug incorrect
- IC igniter trouble
- Pickup coil trouble
- Ignition coil trouble

#### Fuel/air mixture incorrect:

- Pilot screw maladjusted
- Pilot jet, or air passage clogged
- Air bleed pipe bleed holes clogged
- Pilot passage clogged
- Air cleaner clogged, poorly sealed, or missing
- Starter plunger stuck open
- Fuel level in carburetor float bowl too high or too low
- Fuel tank air vent obstructed
- Carburetor holder loose
- Air cleaner duct loose
- Air cleaner O-ring damaged
- Fuel pump trouble
- Fuel pump relay trouble
- Fuel filter clogged

#### Compression low:

- Spark plug loose
- Cylinder head not sufficiently tightened down
- No valve clearance
- Cylinder, piston worn
- Piston ring bad (worn, weak, broken, or sticking)
- Piston ring/groove clearance excessive
- Cylinder head warped
- Cylinder head gasket damaged
- Valve spring broken or weak
- Valve not seating properly (valve bent, worn, or carbon accumulation on the seating surface)

#### Other:

- IC igniter trouble
- Carburetors not synchronizing
- Carburetor vacuum piston doesn't slide smoothly
- Carburetor vacuum piston diaphragm damage
- Engine oil viscosity too high
- Drive train trouble
- Brake dragging

Air suction valve trouble  
Vacuum switch valve trouble

### Poor Running or No Power at High Speed:

#### Firing incorrect:

Spark plug dirty, broken, or maladjusted  
Spark plug cap or high tension wiring trouble  
Spark plug cap shorted or not in good contact  
Spark plug incorrect  
IC igniter trouble  
Pickup coil trouble  
Ignition coil trouble

#### Fuel/air mixture incorrect:

Starter plunger stuck open  
Main jet clogged or wrong size  
Jet needle or needle jet worn  
Air jet clogged  
Fuel level in carburetor float bowl too high or too low  
Bleed holes of needle jet holder or needle jet clogged  
Air cleaner clogged, poorly sealed, or missing  
Air cleaner duct loose  
Air cleaner O-ring damaged  
Water or foreign matter in fuel  
Carburetor holder loose  
Fuel tank air vent obstructed  
Fuel tap clogged  
Fuel line clogged  
Fuel pump trouble  
Fuel pump relay trouble  
Fuel filter clogged

#### Compression low:

Spark plug loose  
Cylinder head not sufficiently tightened down  
No valve clearance  
Cylinder, piston worn  
Piston ring bad (worn, weak, broken, or sticking)  
Piston ring/groove clearance excessive  
Cylinder head gasket damaged  
Cylinder head warped  
Valve spring broken or weak  
Valve not seating properly (valve bent, worn, or carbon accumulation on the seating surface.)

#### Knocking:

Carbon built up in combustion chamber  
Fuel poor quality or incorrect  
Spark plug incorrect  
IC igniter trouble

#### Miscellaneous:

Throttle valve won't fully open  
Carburetor vacuum piston doesn't slide smoothly  
Carburetor vacuum piston diaphragm damaged  
Brake dragging  
Clutch slipping  
Overheating  
Engine oil level too high  
Engine oil viscosity too high  
Drive train trouble  
Air suction valve trouble  
Vacuum switch valve trouble

### Overheating:

#### Firing incorrect:

Spark plug dirty, broken, or maladjusted  
Spark plug incorrect  
IC igniter trouble

#### Fuel/air mixture incorrect:

Main jet clogged or wrong size  
Fuel level in carburetor float bowl too low  
Carburetor holder loose  
Air cleaner duct loose  
Air cleaner poorly sealed, or missing  
Air cleaner O-ring damaged  
Air cleaner clogged  
Fuel pump trouble  
Fuel pump relay trouble  
Fuel filter clogged

#### Compression high:

Carbon built up in combustion chamber

#### Engine load faulty:

Clutch slipping  
Engine oil level too high  
Engine oil viscosity too high  
Drive train trouble  
Brake dragging

#### Lubrication inadequate:

Engine oil level too low  
Engine oil poor quality or incorrect

#### Oil cooler incorrect:

Oil cooler clogged

#### Gauge incorrect:

Water temperature gauge broken  
Water temperature sensor broken

#### Coolant incorrect:

Coolant level too low  
Coolant deteriorated

#### Cooling system component incorrect:

Radiator fin damaged  
Radiator clogged  
Thermostat trouble  
Radiator cap trouble  
Radiator fan switch trouble  
Fan motor broken  
Fan blade damaged  
Water pump not turning  
Water pump impeller damaged

### Over Cooling:

#### Gauge incorrect:

Water temperature gauge broken  
Water temperature sensor broken

#### Cooling system component incorrect:

Radiator fan switch trouble  
Thermostat trouble

### Clutch Operation Faulty:

#### Clutch slipping:

Friction plate worn or warped  
Steel plate worn or warped  
Clutch spring broken or weak  
Clutch slave cylinder trouble  
Clutch hub or housing unevenly worn

**Clutch not disengaging properly:**

- Clutch plate warped or too rough
- Clutch spring compression uneven
- Engine oil deteriorated
- Engine oil viscosity too high
- Engine oil level too high
- Clutch housing frozen on drive shaft
- Clutch slave cylinder trouble
- Clutch hub nut loose
- Clutch hub spline damaged
- Clutch friction plate installed wrong
- Clutch fluid leakage
- Clutch fluid deteriorated
- Clutch master cylinder primary or secondary cup damaged
- Clutch master cylinder scratched inside

**Gear Shifting Faulty:****Doesn't go into gear; shift pedal doesn't return:**

- Clutch not disengaging
- Shift fork bent or seized
- Gear stuck on the shaft
- Gear positioning lever binding
- Shift return spring weak or broken
- Shift return spring pin loose
- Shift mechanism arm spring broken
- Shift mechanism arm broken
- Shift pawl broken

**Jumps out of gear:**

- Shift fork worn, bent
- Gear groove worn
- Gear dogs and/or dog holes worn
- Shift drum groove worn
- Gear positioning lever spring weak or broken
- Shift fork pin worn
- Drive shaft, output shaft, and/or gear splines worn

**Overshifts:**

- Gear positioning lever spring weak or broken
- Shift mechanism arm spring broken

**Abnormal Engine Noise:****Knocking:**

- IC igniter trouble
- Carbon built up in combustion chamber
- Fuel poor quality or incorrect
- Spark plug incorrect
- Overheating

**Piston slap:**

- Cylinder/piston clearance excessive
- Cylinder, piston worn
- Connecting rod bent
- Piston pin, piston pin hole worn

**Valve noise:**

- Valve clearance incorrect
- Valve spring broken or weak
- Camshaft bearing worn
- Valve lifter worn

**Other noise:**

- Connecting rod small end clearance excessive
- Connecting rod big end clearance excessive

- Piston ring worn, broken, or stuck
- Piston seizure, damage
- Cylinder head gasket leaking
- Exhaust pipe leaking at cylinder head connection
- Crankshaft runout excessive
- Engine mounts loose
- Crankshaft bearing worn
- Primary gear worn or chipped
- Camshaft chain tensioner trouble
- Camshaft chain, sprocket, guide worn
- Air suction valve damaged
- Vacuum switch valve damaged
- Alternator shaft coupling rubber damper damaged
- Alternator shaft chain tensioner trouble
- Alternator shaft chain, sprocket, guide worn

**Abnormal Drive Train Noise:****Clutch noise:**

- Clutch rubber damper weak or damaged
- Clutch housing/friction plate clearance excessive
- Clutch housing gear worn

**Transmission noise:**

- Bearings worn
- Transmission gears worn or chipped
- Metal chips jammed in gear teeth
- Engine oil insufficient

**Drive chain noise:**

- Drive chain adjusted improperly
- Drive chain worn
- Rear and/or engine sprocket worn
- Chain lubrication insufficient
- Rear wheel misaligned

**Abnormal Frame Noise:****Front fork noise:**

- Oil insufficient or too thin
- Spring weak or broken

**Rear shock absorber noise:**

- Shock absorber damaged

**Disc brake noise:**

- Pad installed incorrectly
- Pad surface glazed
- Disc warped
- Caliper trouble

**Other noise:**

- Bracket, nut, bolt, etc. not properly mounted or tightened

**Oil Pressure Warning Light Goes On:**

- Engine oil pump damaged
- Engine oil screen clogged
- Engine oil level too low
- Engine oil viscosity too low
- Camshaft bearings worn
- Crankshaft bearings worn
- Oil pressure switch damaged
- Wiring faulty
- Relief valve stuck open
- O-ring at the oil passage in the crankcase damaged

**Exhaust Smokes Excessively:****White smoke:**

- Piston oil ring worn
- Cylinder worn
- Valve oil seal damaged
- Valve guide worn
- Engine oil level too high

**Black smoke:**

- Air cleaner clogged
- Main jet too large or fallen off
- Starter plunger stuck open
- Fuel level in carburetor float bowl too high

**Brown smoke:**

- Main jet too small
- Fuel level in carburetor float bowl too low
- Air cleaner duct loose
- Air cleaner O-ring damaged
- Air cleaner poorly sealed or missing

**Handling and/or Stability Unsatisfactory:****Handlebar hard to turn:**

- Cable routing incorrect
- Hose routing incorrect
- Wiring routing incorrect
- Steering stem locknut too tight
- Steering stem bearing damaged
- Steering stem bearing lubrication inadequate
- Steering stem bent
- Tire air pressure too low

**Handlebar shakes or excessively vibrates:**

- Tire worn
- Swingarm pivot bearings worn
- Rim warped, or not balanced
- Wheel bearing worn
- Handlebar clamp loose
- Steering stem head nut loose

**Handlebar pulls to one side:**

- Frame bent
- Wheel misalignment
- Swingarm bent or twisted
- Steering maladjusted
- Front fork bent
- Right and left front fork oil level uneven

**Shock absorption unsatisfactory:**

- (Too hard)
- Front fork oil excessive
- Front fork oil viscosity too high
- Rear shock absorber adjustment too hard
- Tire air pressure too high
- Front fork bent
- (Too soft)
- Tire air pressure too low
- Front fork oil insufficient and/or leaking
- Front fork oil viscosity too low
- Rear shock adjustment too soft
- Front fork, rear shock absorber spring weak
- Rear shock absorber oil leaking

**Brake Doesn't Hold:**

- Air in the brake line

- Pad or disc worn
- Brake fluid leakage
- Disc warped
- Contaminated pad
- Brake fluid deteriorated
- Primary or secondary cup damaged in master cylinder
- Master cylinder scratched inside

**Battery Trouble:****Battery discharged:**

- Battery faulty (e.g., plates sulphated, shorted through sedimentation, electrolyte insufficient)
- Battery leads making poor contact
- Load excessive (e.g., bulb of excessive wattage)
- Ignition switch trouble
- Alternator trouble
- Wiring faulty

**Battery overcharged:**

- Alternator trouble
- Battery faulty

## General Lubrication

### Lubrication

- Before lubricating each part, clean off any rusty spots with rust remover and wipe off any grease, oil, dirt, or grime.
- Lubricate the points listed below with indicated lubricant.

### NOTE

- *Whenever the vehicle has been operated under wet or rainy conditions, or especially after using a high-pressure water spray, perform the general lubrication.*

### Pivots: Lubricate with Motor Oil.

- Clutch Lever
- Brake Lever
- Brake Pedal
- Side Stand
- Rear Brake Rod Joint

### Points: Lubricate with Grease.

- Throttle Inner Cable Lower Ends
- Choke Inner Cable Lower End
- Speedometer Inner Cable\*

(\*): Grease the lower part of the inner cable sparingly.

### Cables: Lubricate with Rust Inhibiter.

- Choke Cable
- Throttle Cables

**Special Tool – Pressure Cable Luber: K56019-021 [A]**

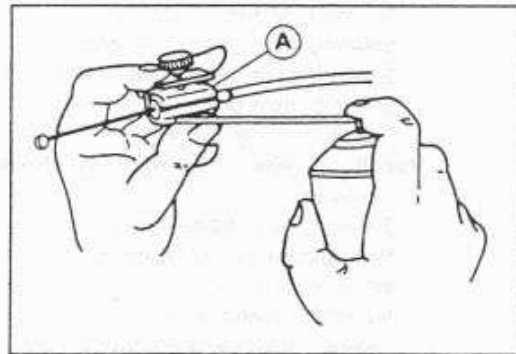



## Nut, Bolt, and Fastener Tightness

### Tightness Inspection

- Check the tightness of the bolts and nuts listed here. Also, check to see that each cotter pin is in place and in good condition.

#### NOTE

○ For the engine fasteners, check the tightness of them when the engine is cold (at room temperature).

- ★ If there are loose fasteners, retorque them to the specified torque following the specified tightening sequence. Refer to the appropriate chapter for torque specifications. If torque specifications are not in the appropriate chapter, see the Standard Torque Table. For each fastener, first loosen it by 1/2 turn, then tighten it.
- ★ If cotter pins are damaged, replace them with new ones.

### Nut, Bolt and Fastener to be checked

#### Wheels:

- Front Axle Nut
- Front Axle Clamp Bolts
- Rear Axle Nut
- Rear Axle Nut Cotter Pin

#### Brakes:

- Front Master Cylinder Clamp Bolts
- Caliper Mounting Bolts
- Rear Master Cylinder Mounting Bolts
- Brake Lever Pivot Nut
- Brake Pedal Bolt
- Brake Rod Joint Cotter Pin

#### Suspension:

- Front Fork Clamp Bolts
- Front Fender Mounting Bolts
- Rear Shock Absorber Mounting Bolts
- Swingarm Pivot Shaft Nut
- Uni-Trak Link Nuts

#### Steering:

- Stem Head Nut
- Handlebar Mounting Bolts

#### Engine:

- Engine Mounting Bolts
- Cylinder Head Bolts
- Muffler Mounting Bolts
- Exhaust Pipe Holder Nuts
- Muffler Connecting Clamp Bolt
- Clutch Master Cylinder Clamp Bolts
- Clutch Lever Pivot Nut

#### Others:

- Side Stand Bolt
- Footpeg Mounting Bolts
- Footpeg Bracket Mounting Bolts

Unit Conversion Table

Prefixes for Units:

Prefix	Symbol	Power
mega	M	x 1 000 000
kilo	k	x 1 000
centi	c	x 0.01
milli	m	x 0.001
micro	μ	x 0.000001

Units of Length:

km	x	0.6214	=	mile
m	x	3.281	=	ft
mm	x	0.03937	=	in

Units of Torque:

N-m	x	0.1020	=	kg-m
N-m	x	0.7376	=	ft-lb
N-m	x	8.851	=	in-lb

Units of Mass:

kg	x	2.205	=	lb
g	x	0.03527	=	oz

kg-m	x	9.807	=	N-m
kg-m	x	7.233	=	ft-lb
kg-m	x	86.80	=	in-lb

Units of Volume:

L	x	0.2642	=	gal (US)
L	x	0.2200	=	gal (imp)
L	x	1.057	=	qt (US)
L	x	0.8799	=	qt (imp)
L	x	2.113	=	pint (US)
L	x	1.816	=	pint (imp)
mL	x	0.03381	=	oz (US)
mL	x	0.02816	=	oz (imp)
mL	x	0.06102	=	cu in

Units of Pressure:

kPa	x	0.01020	=	kg/cm <sup>2</sup>
kPa	x	0.1450	=	psi
kPa	x	0.7501	=	cm Hg
kg/cm <sup>2</sup>	x	98.07	=	kPa
kg/cm <sup>2</sup>	x	14.22	=	psi
cm Hg	x	1.333	=	kPa

Units of Force:

N	x	0.1020	=	kg
N	x	0.2248	=	lb
kg	x	9.807	=	N
kg	x	2.205	=	lb

Units of Speed:

km/h	x	0.6214	=	mph
------	---	--------	---	-----

Units of Power:

kW	x	1.360	=	PS
kW	x	1.341	=	HP
PS	x	0.7355	=	kW
PS	x	0.9863	=	HP

Units of Temperature:

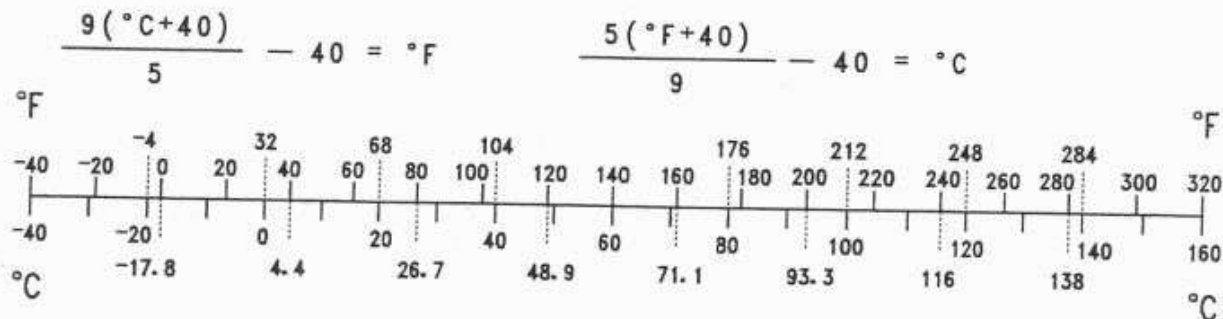

CONTENTS

1. Introduction	1
2. Safety Precautions	2
3. Operation	3
4. Maintenance	4
5. Troubleshooting	5
6. Specifications	6
7. Appendix	7
8. Index	8

Copyright © 2000 by Kawasaki Heavy Industries, Ltd.



KAWASAKI HEAVY INDUSTRIES, LTD.  
KAWASAKI HEAVY INDUSTRIES, LTD.

Part No. 3224-722-02

### MODEL APPLICATION

Year	Model	Beginning Frame No.
1996	ZX750-N1	JKAZXDN1□TA000501, or JKAZX750NNA000501, or ZX750N-000501
	ZX750-P1	JKAZXDP1□TA000001, or JKAZX750PPA000001, or ZX750P-000001
1997	ZX750-N2	JKAZXDN1□VA001501, or JKAZX750NNA001501
	ZX750-P2	JKAZXDP1□VA013001, or JKAZX750PPA013001
1998	ZX750-P3	JKAZXDPI□WA025001, or JKAZX750PPA025001
1999	ZX750-P4	JKAZXDPI□KA036001, or JKAZX750PPA036001

□ : This digit in the frame number changes from one machine to another.



KAWASAKI HEAVY INDUSTRIES, LTD.  
Consumer Products & Machinery Group

Part No. 99924-1193-03

Printed in Japan